

Fork Positioners

Fork Positioner that guarantees a constant and synchronized movement of the forks by standard installation of a flow divider. Designed to withstand extreme usage cycles. Customized versions can be manufactured on request, with bolted forks and check valve for barrel grabbing. A pressure relief valve is supplied as standard on each model.

673F DOUBLE PIN-TYPE FORK POSITIONER FOR FEM FORKS

REFERENCE	CAPACITY (P) Kg	LOAD CENTRE (CC) mm	ISO 2328 - FEM	CARRIAGE WIDTH (A) mm	EXTERNAL HOOKS (B) mm	OPENING RANGE (C MIN) mm (C MAX) mm		FORKS WIDTH (D) mm	THICKNESS (S) mm	CENTER OF GRAVITY (CG) mm	WEIGHT (Q) Kg
18ZFA2C0001	2500	500	II	980	750	360	930	120	117	38	170
18ZFA2C0002	2500	500	II	1040	750	360	990	120	117	36	175
18ZFA2C0003	2500	500	II	1100	750	360	1050	120	117	34	180
18ZFA2C0004	2500	500	II	1150	750	360	1100	120	117	40	190
18ZLL3C0003	5000	500	III	1150	880	400	1080	150	148	72	235
18ZLL3C0001	5000	500	III	1250	880	400	1180	150	148	69	260
18ZLL3C0004	5000	500	III	1350	880	400	1280	150	148	67	285
18ZLL3C0002	5000	500	III	1560	1210	400	1490	150	148	61	315
18ZLL3C0005	5000	500	III	1660	1210	400	1590	150	148	58	340
18ZLM4C0001	5000	600	IV	1200	900	550	1110	150	158	70	410
18ZLM4C0002	5000	600	IV	1400	1100	550	1310	150	158	68	450
18ZR04C0003	8000	600	IV	1740	1450	550	1650	200	158	61	530
18ZR04C0004	8000	600	IV	1800	1500	550	1710	200	158	61	550
18ZR04C0005	8000	600	IV	2000	1700	550	1910	200	158	57	610
18ZR14C0001	8000	900	IV	2200	2150	550	2110	200	158	56	670
18ZR14C0002	8000	900	IV	2400	2150	550	2310	200	158	54	705

Hydraulic functions required: 1 | Maximum working pressure: 80 bar

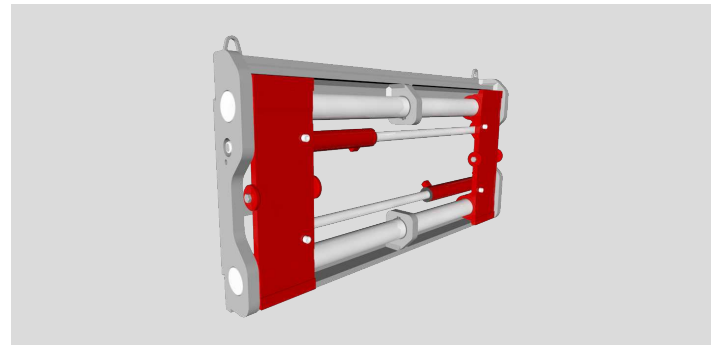
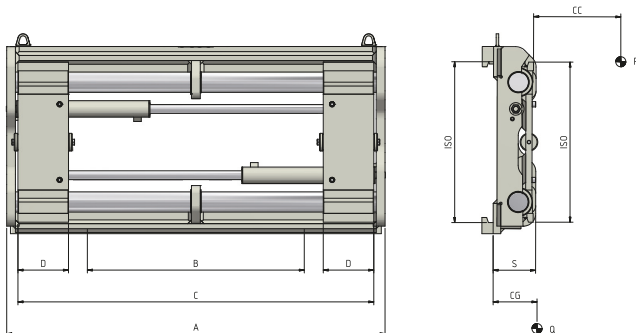

OPTIONS

- Pipes and Fitting Kit.
- Quick Release Hoses couplings Kit.
- Pressure Gauge.
- Bronze Wear Pads.
- Quick Release Hooks.
- Drilling for Load Backrest.
- Solenoid Valve two Functions with Electric Kit (specify voltage).
- Pressure Relief Valve supplied as standard.
- Check Valve for Barrel Grabbing.
- Sideshifting Valve.
- Semi-Integral Sideshift.
- Automatic Greasing System for Semi-Integral Sideshift.

ADDITIONAL EQUIPMENT ON REQUEST

- Forks Positioners with special width and/or stroke.
- Forks with any section and lenght.
- Load Backrest of various widths and heights.
- Welded Forks, Bolted Forks or Telescopic Forks.

OIL FLOW RATE

TYPE	ISO 2328 - FEM	MIN CAPACITY (L/min)	MAX CAPACITY (L/min)	RECOMMENDED CAPACITY (L/min)
673F	ISO 2	10	20	15
673F	ISO 3	15	25	20
673F	ISO 4 - 18ZR0	30	60	40
673F	ISO 4 - 18ZR1	35	60	45

- A - Pin-Type Forks
- B - Bolted Forks
- C - Welded Forks
- D - Telescopic Forks

