

917.T4 Double Fork Positioner with Semi-Integral Sideshift (1-2-4 Pallets)

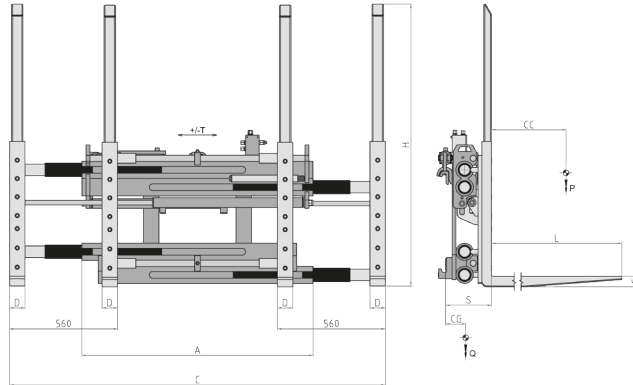

Hydraulic functions: 2 | Max working pressure: 200 Bar

Features:

- One or two pallets side by side and two or four pallets in double depth.
- Smaller frame ease dimension.
- 4 bolt-on forks supplied with reinforced heel and load backrest, for easier replacement operations.
- Easier and safer manoeuvres, even in narrow spaces.

Special Equipment:

- Special widths and/or strokes.
- Custom made Forks.
- Custom made Load Backrest.
- Load Stabiliser with custom made dimensions/openings.

Article	Attachment Capacity	Load Centre of Gravity	ISO	Carriage Width	Opening Range		Forks	Forks Height	Stroke	Thickness	Centre of Gravity	Weight
					C Min (mm)	C Max (mm)						
N°	P (kg)	CC (mm)	2328	A (mm)	C Min (mm)	C Max (mm)	DxGxL (mm)	H (mm)	T (mm)	S (mm)	CG (mm)	Q (kg)
15RFC3A1001	2500	1200	3a	1400	560	1940	80x60x2400	1460	± 100	225	480	1050
15RJ64A1001	3600	1200	4a	1400	560	1940	80x70x2400	1460	± 150	235	435	1320
15RKY4A1001	4600	1200	4a	1400	560	1940	80x70x2400	1460	± 150	235	445	1380

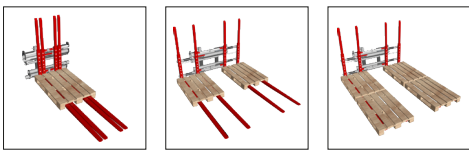

Oil flow rate		
ISO	(L/min)	
	↔	↕
3	15	45
4	20	45

- ↔ Shifting
- ↕ Opening
- ↕ Closing

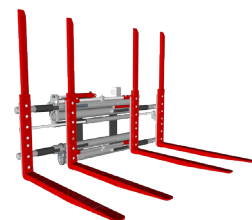

Please refer to our catalogue for further Special Equipment