

917.2 Double Fork Positioner (1-2 Pallets)

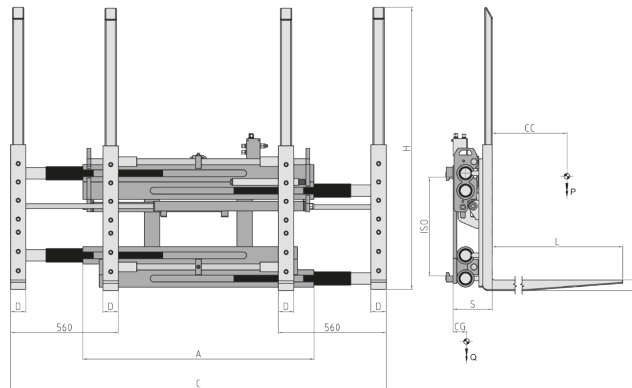

Hydraulic functions: 1 | Max working pressure: 200 Bar

Features:

- One or two pallets side by side.
- Smaller frame ease dimension.
- 4 bolt-on forks supplied with reinforced heel and load backrest, for easier replacement operations.
- Easier and safer manoeuvres, even in narrow spaces.

Special Equipment:

- Special widths and/or strokes.
- Custom made Forks.
- Custom made Load Backrest.
- Load Stabiliser with custom made dimensions/openings.

Article	Attachment Capacity	Load Centre of Gravity	ISO	Carriage Width	Opening Range		Forks	Forks Height	Thickness	Centre of Gravity	Weight
N°	P (kg)	CC (mm)	2328	A (mm)	C Min (mm)	C Max (mm)	DxGxL (mm)	H (mm)	S (mm)	CG (mm)	Q (kg)
15REA2A0004	2200	600	2a	1200	560	1940	80x40x1150	1460	154	190	450
15RFB2A0005	2500	600	2a	1200	560	1940	80x50x1150	1460	164	205	495
15RFB3A0005	2600	600	3a	1200	560	1940	80x50x1150	1460	164	210	535
15RHF3A0005	3200	600	3a	1200	560	1940	80x60x1150	1460	174	220	605
15RJV3A0003	4000	600	3a	1400	560	1940	80x60x1150	1460	174	195	620

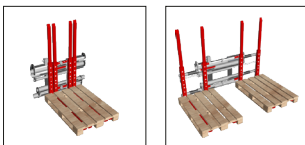

Oil flow rate	
ISO	(L/min)
2	45
3	45

↑ Opening  
↓ Closing

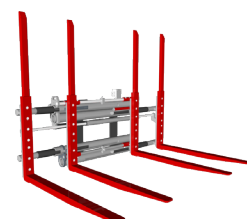

Please refer to our catalogue for further Special Equipment