

917.4 Double Fork Positioner (1-2-4 Pallets)

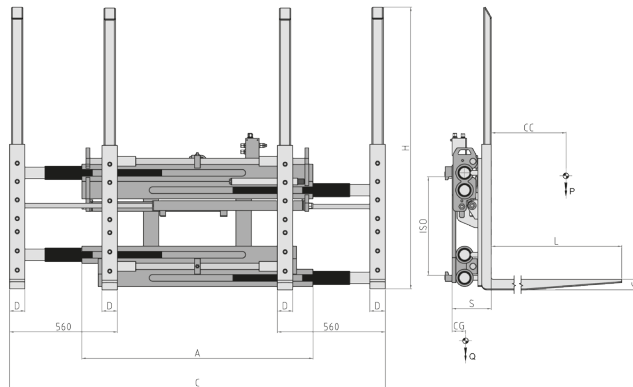

Hydraulic functions: 1 | Max working pressure: 200 Bar

Features:

- One or two pallets side by side and two or four pallets in double depth.
- Smaller frame ease dimension.
- 4 bolt-on forks supplied with reinforced heel and load backrest, for easier replacement operations.
- Easier and safer manoeuvres, even in narrow spaces.

Special Equipment:

- Special widths and/or strokes.
- Custom made Forks.
- Custom made Load Backrest.
- Load Stabiliser with custom made dimensions/openings.

Article	Attachment Capacity	Load Centre of Gravity	ISO	Carriage Width	Opening Range		Forks	Forks Height	Thickness	Centre of Gravity	Weight
					C Min (mm)	C Max (mm)					
N°	P (kg)	CC (mm)	2328	A (mm)	C Min (mm)	C Max (mm)	DxGxL (mm)	H (mm)	S (mm)	CG (mm)	Q (kg)
15RFC3A0001	2500	1200	3a	1400	560	1940	80x60x2400	1460	200	480	980
15RJ64A0001	3600	1200	4a	1400	560	1940	80x70x2400	1460	210	435	1250
15RKY4A0001	4600	1200	4a	1400	560	1940	80x70x2400	1460	210	445	1310

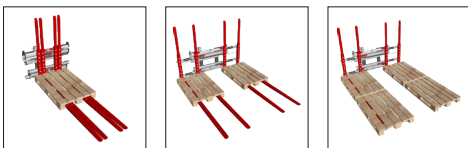

Oil flow rate	
ISO	(L/min)
3	45
4	45

↑↓ Opening
Closing

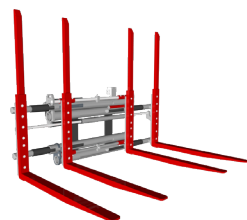

Please refer to our catalogue for further Special Equipment