

30I.474.I60 360° Rotating Drum Clamp for one or two Drums

Hydraulic functions: 2 | Max working pressure: 175 Bar

Features:

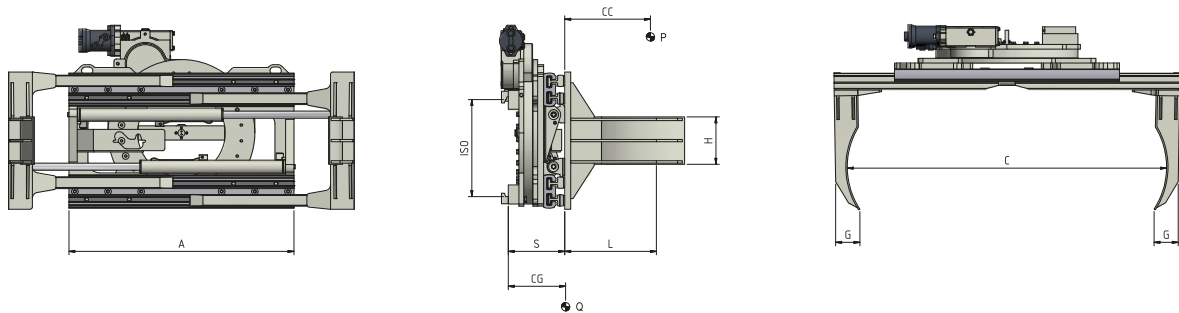

- Clamping and rotation of 1 or 2 Drums at once. • Adjustable clamping force with hydraulic valve. • Pressure Relief Valve. • Non-return Valve. • Regenerative Valve.

Special Equipment:

- Custom made widths/openings. • Custom made Blades. • Load Backrest. • "V" shaped Plates for gripping drums with different diameters. • Sideshifting Valve or Semi-Integral Sideshift.

Article	Attachment Capacity	Load Centre of Gravity	ISO	Frame Width	Opening Range		Blades	Thickness	Centre of Gravity	Weight
N°	P (kg)	CC (mm)	2328	A (mm)	C Min (mm)	C Max (mm)	GxHxL (mm)	S (mm)	CG (mm)	Q (kg)
11M23AQ2A0001	1200	330	2	950	490	1730	100x200x330	234	132	390
11M23BE2A0001	1400	330	2	950	450	1600	100x200x330	267	146	476

Oil flow rate

ISO	(L/min)		 Clamping  Rotation
	→ ←	↻	
2	25	20	

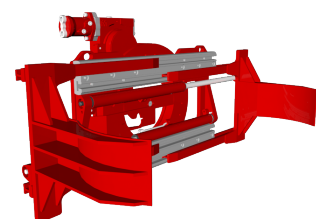

Please refer to our catalogue for further Special Equipment