

30I PPT SLS 360° Rotator with Integral Fork Positioner, Pin-Type Forks and Integral Sideshift

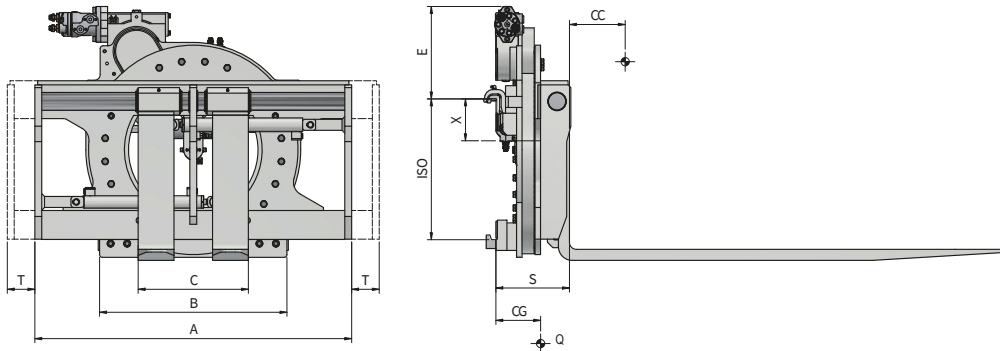

Hydraulic functions: 3 | Max working pressure: 175 Bar

Features:

- Continuous rotation of 360° in both directions.
- Suitable for loads of different sizes.
- Recommended use of forks with reinforced lower hooks.

Special Equipment:

- Special widths and/or strokes.
- Custom made Forks.
- Load Backrest.
- Special versions for Agriculture, Fish Industry and Foundries.

Article	Attachment Capacity	Load Centre of Gravity	ISO	Carriage Width	Height	Minimum Fork Carriage	Rotation Centre	Opening Range		Forks	Torque	Stroke	Thickness	Centre of Gravity	Weight
N°	P (kg)	CC (mm)	2328	A (mm)	E (mm)	B (mm)	X (mm)	C Min (mm)	C Max (mm)	DxGxL (mm)	Nm P	T (mm)	S (mm)	CG (mm)	Q (kg)
23EC42A4003	1600	500	2a	1000	314	700	141	360	930	100x40x1200	6700	± 100	246,5	254	380
23EE82A4001	2200	500	2a	1100	314	700	141	360	1030	100x40x1200	6700	± 100	246,5	252	395
23EHS3A4007	3000	500	3a	1150	335,5	900	185	400	1080	120x45x1200	7400	± 100	266,5	240	543
23EHS3A4008	3400	500	3a	1270	335,5	900	185	400	1200	120x45x1200	12300	± 100	266,5	237	549
23EK63A4009	4200	500	3a	1350	335,5	900	185	400	1280	150x50x1200	12300	± 100	271,5	271	593
23EL83A4008	4800	500	3a	1660	335,5	900	185	400	1590	150x50x1200	12300	± 100	271,5	267	610
23ELM3A4002	5000	600	3a	1350	305,5	960	185	550	1260	150x60x1200	13000	± 100	364	270	950
23ELM4A4005	5000	600	4a	1600	305,5	960	262	550	1510	150x60x1200	13000	± 100	343,5	274	1026
23END4A4004	5500	600	4a	1800	305,5	960	262	550	1710	150x60x1200	14100	± 100	343,5	262	1150
23EQ54A4004	7000	600	4a	2000	287	1300	262	550	1910	150x60x1200	16200	± 150	386,5	270	1320
23ER04A4002	8000	600	4a	2000	287	1300	262	550	1910	200x60x1200	24200	± 150	386,5	293	1400

Oil flow rate

ISO	(L/min)		
	↔	↑↓	↻
2	10	25	35
3	15	25	35
4	18	30	35

- ↔ Shifting
- ↑↓ Opening
- ↻ Closing
- ↻ Rotation

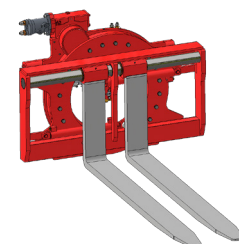

Please refer to our catalogue for further Special Equipment