

219 360° Box Rotator with L-shaped arm

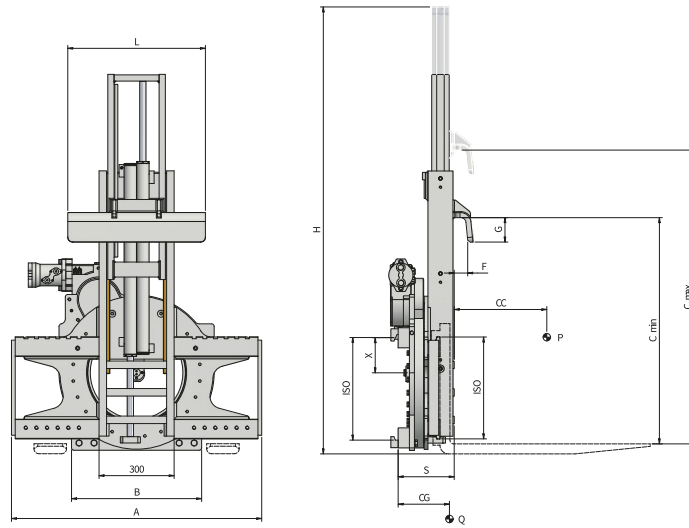

Hydraulic functions: 2 | Max working pressure: 175 Bar

Features:

- Suitable for emptying boxes (big drawers) in any use (scrap, recycling, agricultural sector).
- Special box blocking system that can be actuated during rotation.

Special Equipment:

- Special widths and/or strokes.
- Forks.
- Hooks with custom made strokes and dimensions.
- Load Backrest.

Article	Attachment Capacity	Load Centre of Gravity	ISO	Carriage Width	Height	Minimum Fork Carriage	Rotation Centre	Box H From the Forks Level	Hook Dimension	Thickness	Centre of Gravity	Weight
N°	P (kg)	CC (mm)	2328	A (mm)	H (mm)	B (mm)	X (mm)	C Min (mm) C Max (mm)	FxGxL (mm)	S (mm)	CG (mm)	Q (kg)
25C342A0013	2200	500	2	1000	1300	500	141	300 1000	55x100x500	225	150	310
25C342A0020	2200	500	2	1100	1300	500	141	300 1000	60x60x600	225	150	320
25C3Q3A0004	3000	500	3	1150	2100	750	185	300 1400	70x100x300	194	110	460

Accessories on request

SLS - Semi-Integral Sideshift (requires an additional hydraulic function)

Oil flow rate		
ISO	(L/min)	
	↻	↑↓
2	25	25
3	25	25

↻ Rotation
 ↑↓ Vertical
 ↑↓ Opening/Closing

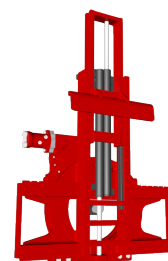

Please refer to our catalogue for further Special Equipment