

343 SF Roll Clamp with 90° forward tipping and short fixed arm

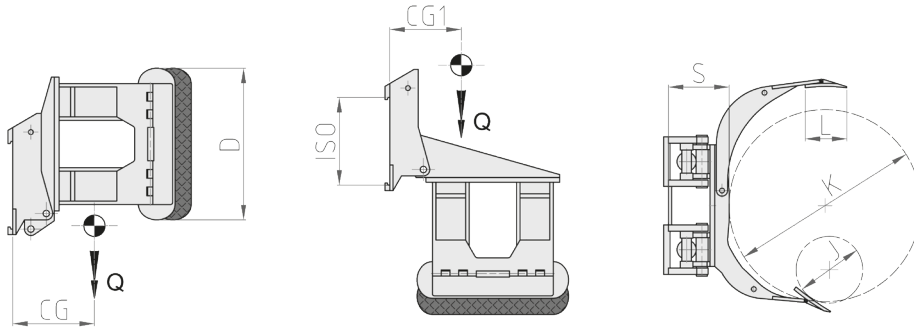

Hydraulic functions: 2 | Max working pressure: 175 Bar

Features:

- Short fixed arm and long entire arm.
- 90° frontal tipping to take rolls lying perpendicularly to the Forklift.

Special Equipment:

- Custom made capacities/openings.
- Custom made Contact Pads.
- Rotating or Fixed Clamp with parallel arms with reduced dimensions for container loading/unloading operations.

Article	Attachment Capacity	ISO	Rolls Diameter		Contact Pads	Thickness	Centre of Gravity	Centre of Gravity	Weight
N°	P (kg)	2328	J (mm)	K (mm)	DxL (mm)	S (mm)	CG (mm)	CG1 (mm)	Q (kg)
21K002G2C0001	900	2	350	1100	700x200	235	215	320	510
21K002G2C0002	900	2	350	1400	700x200	235	220	340	560
21K002Q2C0001	1300	2	400	1150	750x250	235	235	360	590
21K002Q2C0002	1300	2	400	1300	750x250	235	240	370	615
21K00342C0001	2000	2	400	1300	850x250	250	250	400	730
21K00343C0001	2000	3	400	1300	850x250	265	250	400	800
21K00343C0002	2000	3	400	1600	850x250	265	255	420	850
21K003G3C0001	2600	3	550	1300	900x250	300	260	430	990
21K003G3C0002	2600	3	750	1600	900x250	300	270	460	1040
21K003Q3C0001	3000	3	400	1300	1015x300	310	275	455	1070
21K003W4C0001	3600	4	750	1800	1050x300	320	280	505	1495

Oil flow rate		
ISO	(L/min)	
	→ ←	↻
2	25	20
3	30	20
4	35	25

→|← Clamping
↻ Tipping

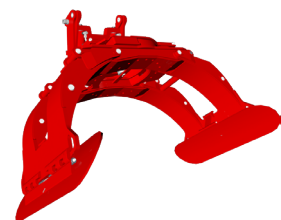

Please refer to our catalogue for further Special Equipment