

## 673 FS SLS Double Pin-Type Fork Positioner with Welded Forks and Integral Sideshift

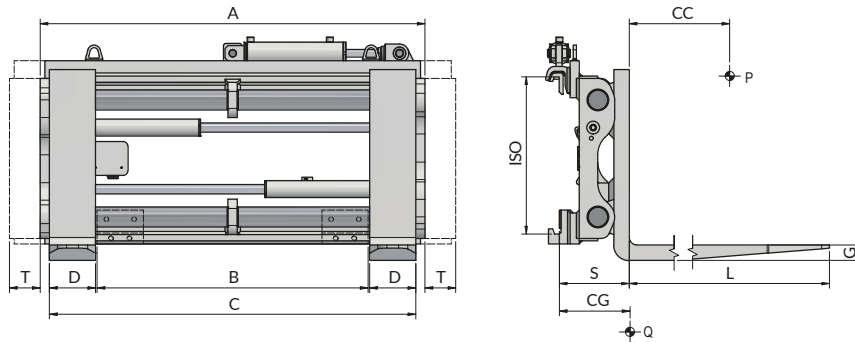

Hydraulic functions: 2 | Max working pressure: 80 Bar

### Features:

- Flow divider for a constant and synchronised movement of the forks. • For particularly demanding use. • Pressure Relief Valve.

### Special Equipment:

- Special widths and/or openings. • Custom made Forks. • Load Backrest. • Check valve for barrel grabbing.

| Article     | Attachment Capacity | Load Centre of Gravity | ISO  | Carriage Width | Minimum Fork Carriage | Opening Range |            | Forks       | Stroke | Thickness | Centre of Gravity | Weight |
|-------------|---------------------|------------------------|------|----------------|-----------------------|---------------|------------|-------------|--------|-----------|-------------------|--------|
| N°          | P (kg)              | CC (mm)                | 2328 | A (mm)         | B (mm)                | C Min (mm)    | C Max (mm) | DxGxL (mm)  | T (mm) | S (mm)    | CG (mm)           | Q (kg) |
| 18YFA2A2001 | 2500                | 500                    | 2    | 980            | 950                   | 360           | 930        | 120x40x1200 | ± 100  | 188       | 247               | 270    |
| 18YFA2A2002 | 2500                | 500                    | 2    | 1040           | 950                   | 360           | 990        | 120x40x1200 | ± 100  | 188       | 246               | 280    |
| 18YFA2A2003 | 2500                | 500                    | 2    | 1100           | 950                   | 360           | 1050       | 120x40x1200 | ± 100  | 188       | 244               | 290    |
| 18YFA2A2004 | 2500                | 500                    | 2    | 1150           | 950                   | 360           | 1100       | 120x40x1200 | ± 100  | 188       | 241               | 300    |
| 18YLL3A2001 | 5000                | 500                    | 3    | 1150           | 950                   | 400           | 1080       | 150x50x1200 | ± 100  | 227       | 265               | 460    |
| 18YLL3A2002 | 5000                | 500                    | 3    | 1250           | 1080                  | 400           | 1180       | 150x50x1200 | ± 100  | 227       | 260               | 475    |
| 18YLL3A2003 | 5000                | 500                    | 3    | 1350           | 1050                  | 400           | 1280       | 150x50x1200 | ± 100  | 227       | 254               | 490    |
| 18YLL3A2004 | 5000                | 500                    | 3    | 1560           | 1300                  | 400           | 1490       | 150x50x1200 | ± 100  | 227       | 244               | 520    |
| 18YLL3A2005 | 5000                | 500                    | 3    | 1660           | 1300                  | 400           | 1590       | 150x50x1200 | ± 100  | 227       | 239               | 535    |
| 18YLM4A2004 | 5000                | 600                    | 4    | 1200           | 1100                  | 550           | 1110       | 150x60x1200 | ± 100  | 255       | 240               | 620    |
| 18YLM4A2005 | 5000                | 600                    | 4    | 1400           | 1100                  | 550           | 1310       | 150x60x1200 | ± 100  | 255       | 232               | 660    |
| 18YR04A2001 | 8000                | 600                    | 4    | 1740           | 1130                  | 550           | 1650       | 200x60x1200 | ± 150  | 253       | 239               | 795    |
| 18YR04A2002 | 8000                | 600                    | 4    | 1800           | 1190                  | 550           | 1710       | 200x60x1200 | ± 150  | 253       | 237               | 805    |
| 18YR04A2003 | 8000                | 600                    | 4    | 2000           | 1400                  | 550           | 1910       | 200x60x1200 | ± 150  | 253       | 231               | 845    |
| 18YR14A2001 | 8000                | 900                    | 4    | 2200           | 2180                  | 550           | 2110       | 200x70x1200 | ± 150  | 264       | 277               | 930    |
| 18YR14A2002 | 8000                | 900                    | 4    | 2400           | 2180                  | 550           | 2310       | 200x70x1200 | ± 150  | 264       | 265               | 950    |

### Accessories on request

Bolt-on Forks

| Oil flow rate |         |        |
|---------------|---------|--------|
| ISO           | (L/min) |        |
|               | ↔       | ↕      |
| 2             | 10      | 15     |
| 3             | 15      | 20     |
| 4             | 18      | 40/45* |

↕ Shifting  
↕ Opening  
↕ Closing

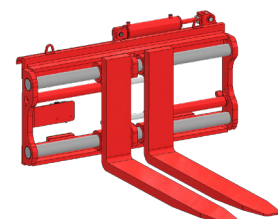

Please refer to our catalogue for further Special Equipment