



ATI3 MATERIAL
HANDLING

INSTRUCTIONS MANUAL FOR USE

INTEGRAL SIDESHIFT

TYPE 122

INDEX

INTEGRAL SIDESHIFT TYPE 122



READ THIS MANUAL VERY CAREFULLY BEFORE STARTING-UP THE MACHINE.

INDEX	1
1 SAFETY RULES	2
2 INTRODUCTION	3
2.1 Use and upkeep of this manual	3
2.2 Description of equipment	4
3 INSTALLATION	8
3.1 Installation	9
3.1.1 Installation the attachment without welded brackets	9
3.1.2 Installation the attachment with welded brackets	15
4 USE RULES	17
5 PERIODIC MAINTENANCE	20
5.1 Maintenance every 100 hours	20
5.2 Maintenance every 300 hours	20
5.3 Maintenance every 1000 hours	21
5.4 Maintenance every 2000 hours	21
6 DISASSEMBLY PROCEDURE	22
6.1 Cylinder removal	22
7 BREAKDOWNS AND SOLUTIONS	24
7.1 Breakdowns and solutions	24
7.2 Lubricate	25

1 SAFETY RULES



Don't carry passengers



Don't cross the mast



Don't pass under the load

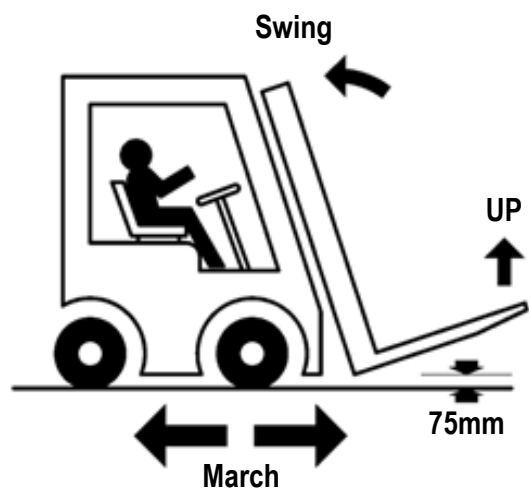

2 INTRODUCTION

2.1 Use and upkeep of this manual

This “User Manual” (hereinafter referred to as Manual) is supplied together with the A.T.I.B. – INTEGRAL SIDESHIFT TYPE 122 pursuant the CE DIRECTIVE 2006/42/CE date 17/05/2006 and amendments.

The information contained here are imperative for the correct use of the attachment and must be known by the personnel who install, use, maintain and repair it.

This manual must be considered integral part of the attachment and must be kept as long as the attachment is in use on any machine in an accessible place, protected, dry and available for immediate consultation.

Should this manual be lost, the operator can apply for the supply of further copies from the manufacturer.

The manufacturer reserves the right to modify this Manual without notice and without the obligation to update the copies previously distributed.

The manufacturer is not liable in cases of:

- Improper use of the attachment;
- Use by untrained personnel;
- Use contrary to current national and international laws;
- Lack of recommended maintenance;
- Non authorised modifications and repairs;
- Use of non original spare parts or parts for other models;
- Failure to adhere, either totally or partially, to these instructions;
- Exceptional circumstances.

The Nominal Capacity of the forklift / Equipment combination is established by the original manufacturer of the forklift and may be lower than that indicated on the identification plate.

Consult the plate of the forklift (Directive 2006/42 / EC)

2.2 Description of equipment

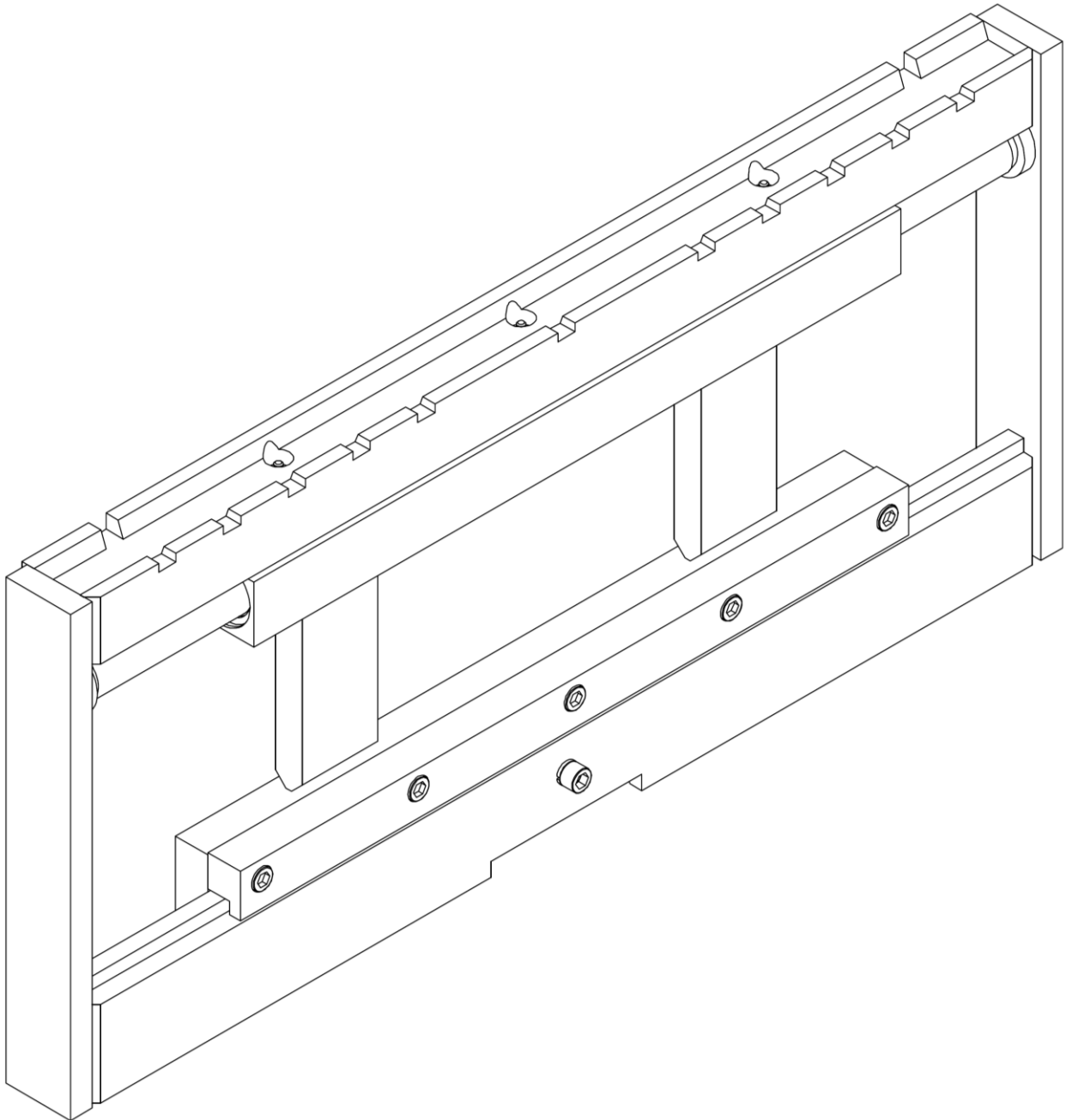

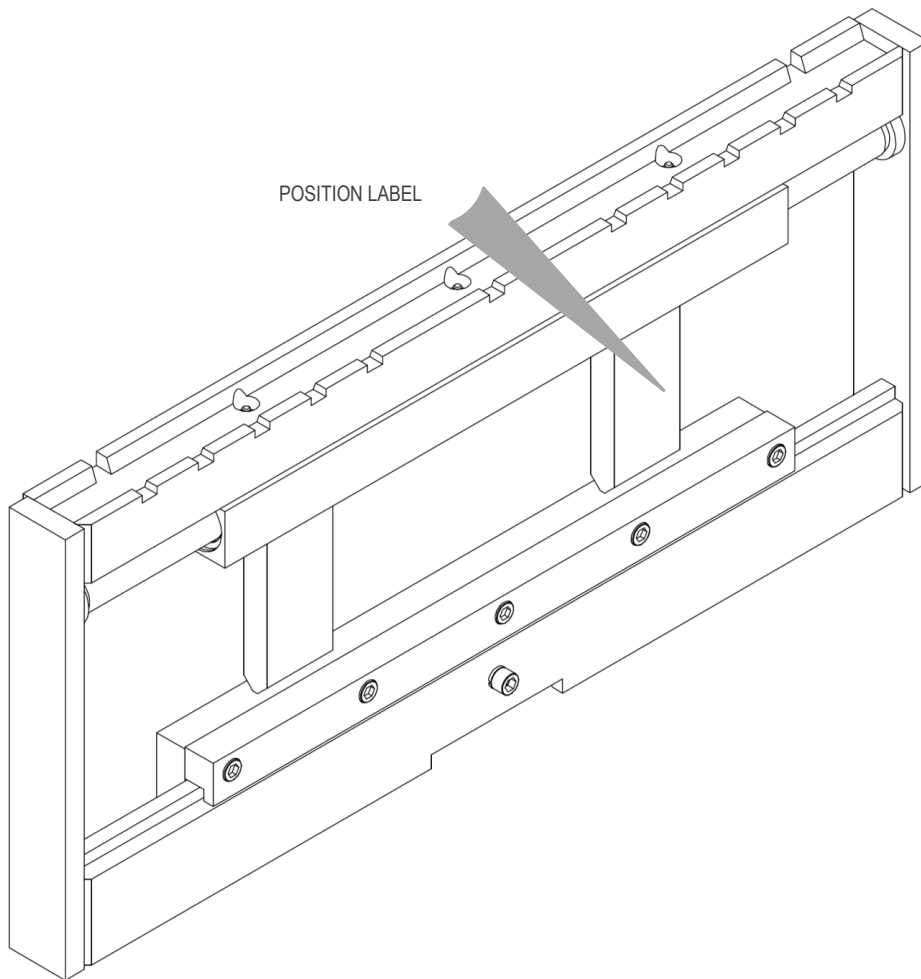

All the A.T.I.B. - INTEGRAL SIDESHIFT TYPE 122 are identified by means of a sticky identification label (

Tab 1) position of identification label on equipment (*Picture 1*), always refer to serial number.



Picture 1

1. TTYPE	8. NOMINAL CAPACITY	kg/mm	11. MAX. TORQUE	daN m
2. CODE	9. CLAMPING CAPACITY	kg/mm	 	
3. SERIAL N°	10. MAX. OPERATING PRESSURE	bar		
4. YEAR OF MANUFACTURE	WARNING: RESPECT THE RATED CAPACITY OF TRUCK AND ATTACHMENT COMBINED		A.T.I.B. S.r.l. Via Quinzanese snc, 25020 Dello (BS) - ITALIA +39 030/9771711 info@atib.com - atib.com	
5. WEIGHT				
6. THICKNESS				
7. CENTER OF GRAVITY				

Tab 1

1. TYPE

It identifies the model of the equipment as shown in the catalogue.

2. **CODE**

It identifies the equipment order code.

3. **SERIAL N°**

It progressively identifies the individual equipment.

The series number has been stamped should the tag go missing or be damaged. Always refer to the series number for any kind of information.

4. **YEAR OF COSTRUCTION**

It indicates the year of construction.

5. **WEIGHT**

It indicates the Q weight of the equipment in kg.

6. **THICKNESS**

It indicates the thickness of the equipment in mm.

7. **CENTRE OF GRAVITY**

It indicates the distance in mm of the equipment CG center of gravity from the fork holding plate table.

8. **NOMINAL CAPACITY**

It indicates the maximum P load applicable to the hoisting equipment and the maximum CC barycentric distance of the load itself.

9. **CLAMPING CAPACITY**

It indicates the maximum load that can be lifted by clamping.

10. **MAX OPERATING PRESSURE**

It indicates the maximum pressure applicable to the equipment.

11. **MAX COUPLE**

Not applicable to this equipment.

The A.T.I.B. - INTEGRAL SIDESHIFT TYPE 122 was planned and built to to perform the function of fork holder plate and allow the translation of load lifting and transport groups used by forklifts.

This equipment must be installed directly on the forklift mast, and connected to the distributor by means of a hydraulic circuit; the attachments must then be applied to it (forks, clamps ecc.).

The sideshifting movement through cylinder hydraulic actioning.

The coupling components of the fork holding plate are manufactured in compliance with the ISO 2328 norm.

Two construction solutions are proposed for coupling with the mast:

1. Attachment with welded brackets (design and structural dimensioning charged to the customer).
2. Attachments without brackets (design, structural dimensioning and welding charged to the customer).

3 INSTALLATION

Verify the nominal capacity of equipment

To check the nominal capacity of equipment, consult the identification label

Tab 1 a pag.5)



Make sure that the operator of the forklift is aware of the maximum capacity of the attachments, so as NOT to pose a danger to himself and to the people who work in his vicinity.

Check operating pressure and flow rate of oil

A.T.I.B. advises to respect the hydraulic flow rates and operating pressures shown in *Tab 2*, in order to optimize the operation of the equipment and avoid problems during the work or commissioning phases. The values are indicative and may vary depending on the equipment.

ISO 2328	PORTATA (l/mm)			Max. operating pressure (Bar)
	Min.	Max.	recommended	
122 ISO II	5	15	10	200
122 ISO III	10	20	15	200
122 ISO IV	12	25	18	200

Tab 2



RESPECT THE MAXIMUM WORKING PRESSURES INDICATED

3.1 Installation

3.1.1 Installation the attachment without welded brackets

WITHOUT BRACKET

1. Before installation, verify the condition of the fork carriage, ensuring that it is not deformed.
2. Also make sure that the profiles of the fork holding plate are not deformed, in order to allow a good coupling with the equipment.
3. Check the condition of the pipes, replacing those that are in bad condition.
4. Remove the lower hook **A** (*Picture 2*).

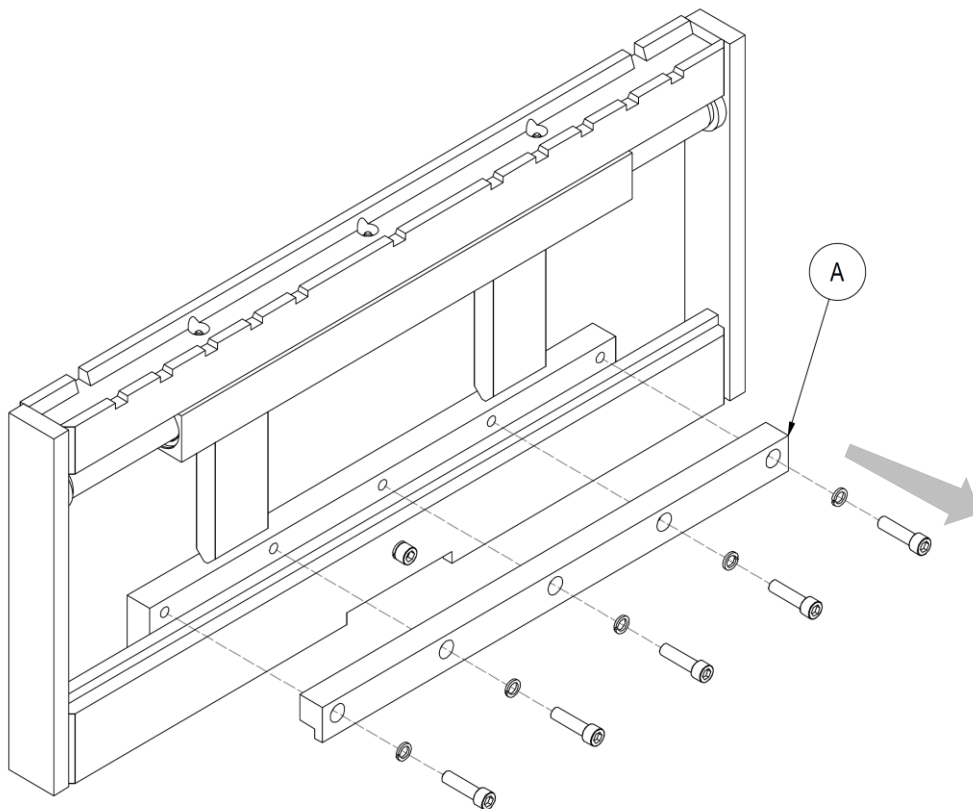

Picture 2

5. Remove the brackets from the original fork holder plate and any chain hooks.
6. Remove the movable frame **D** with belts **E** appropriately sized for the weight of the equipment (*Picture 3*), lifting it with an overhead crane or with a hoist of sufficient capacity.

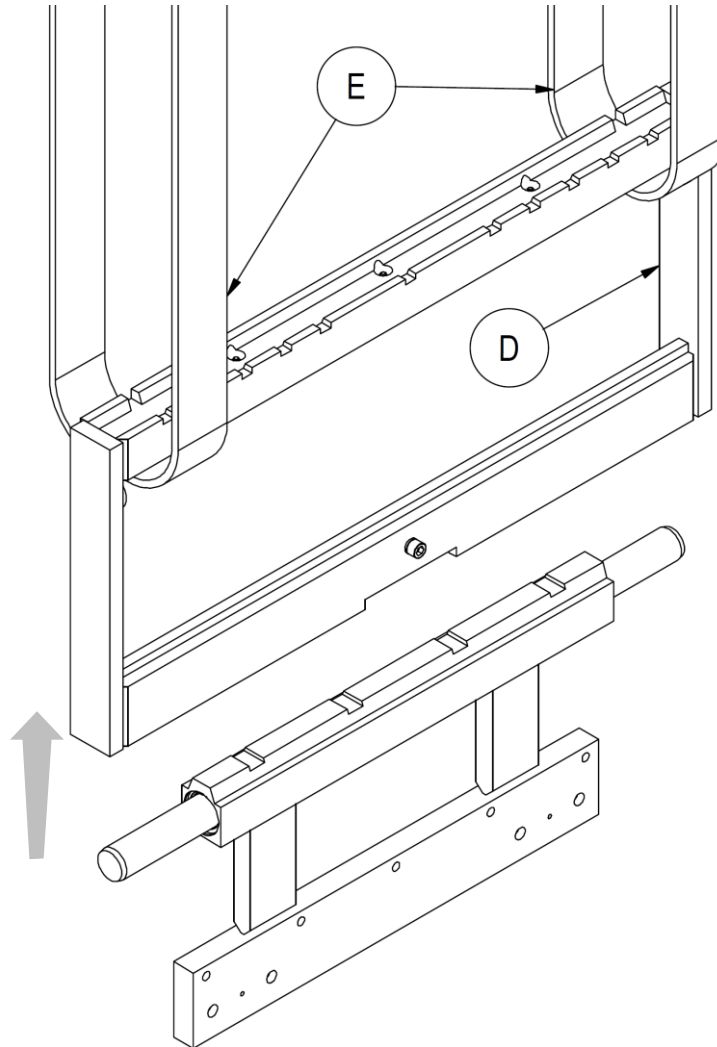

Picture 3

7. Weld your backs to the profiles by contacting A.T.I.B. for the necessary technical information. The welding must be sized and made in such a way as to withstand the stresses foreseen during the use of the equipment and taking into account the material with which the profiles of the equipment are made (generally in Fe 510 C according to UNI EN 10025 02.92, except different prescription).

8. Mount the upper slides **B** and lower slides **C** in their seats (*Picture 4*).

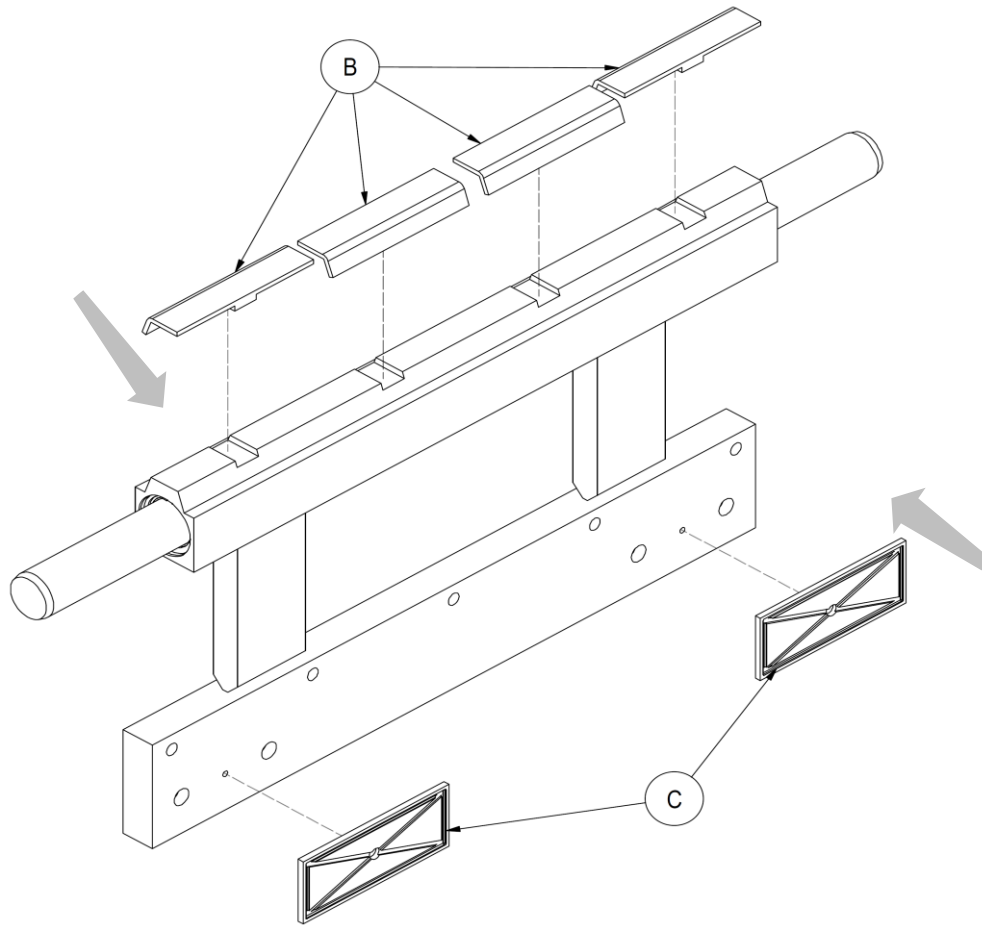

Picture 4

9. Grease the lower part of the mobile frame, where the slides will slide **C** (*Picture 4*).

10. Mount the movable frame **D** from the top of the equipment with the aid of bands appropriately sized to the weight of the equipment (**E**) by an overhead crane or with a hoist of sufficient capacity (*Picture 5*).

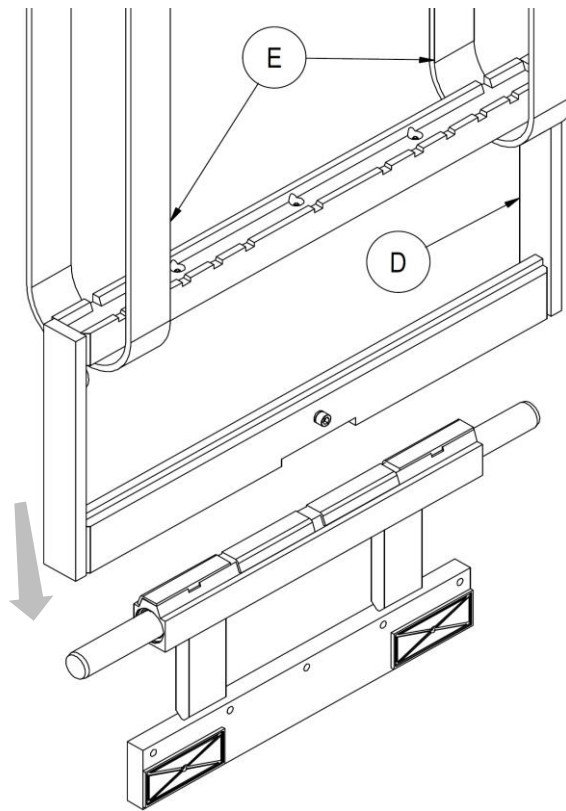

Picture 5

11. Replace the lower hook **A** and then tighten the screws that sustain it (*Picture 6*).

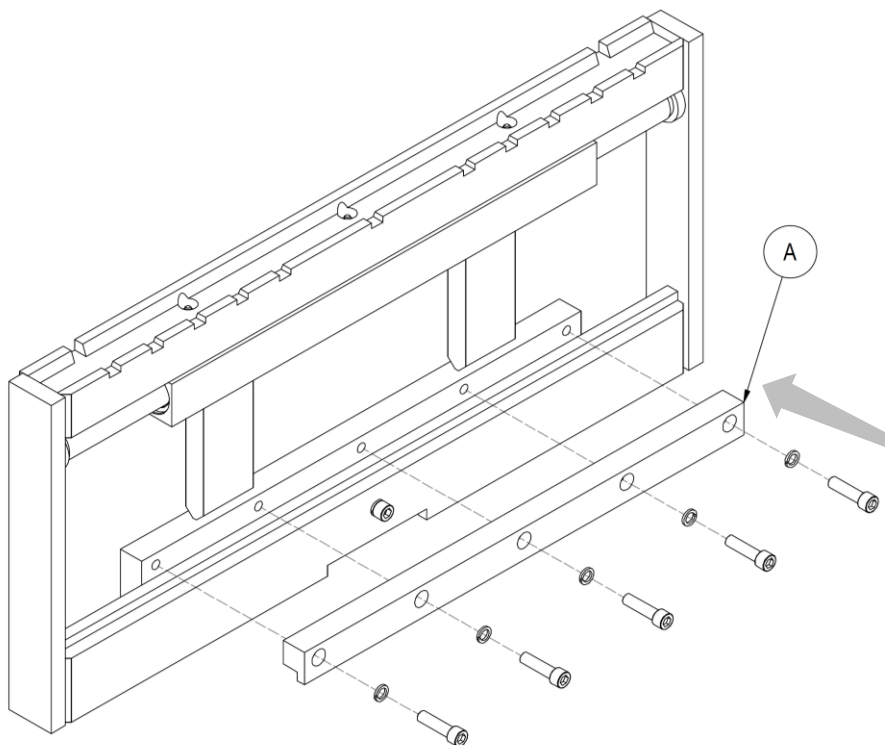

Picture 6

12. Lubricate the sliding parts using the special grease nipples (*Picture 14* and pag. 25).
13. Couple the sliding rollers of the mast to the pins made on the bracket (*Picture 7*), in this picture, as in the following, bearings, bracket and masts indicated are purely indicative, with the sole purpose of showing the correct assembly of the equipment.

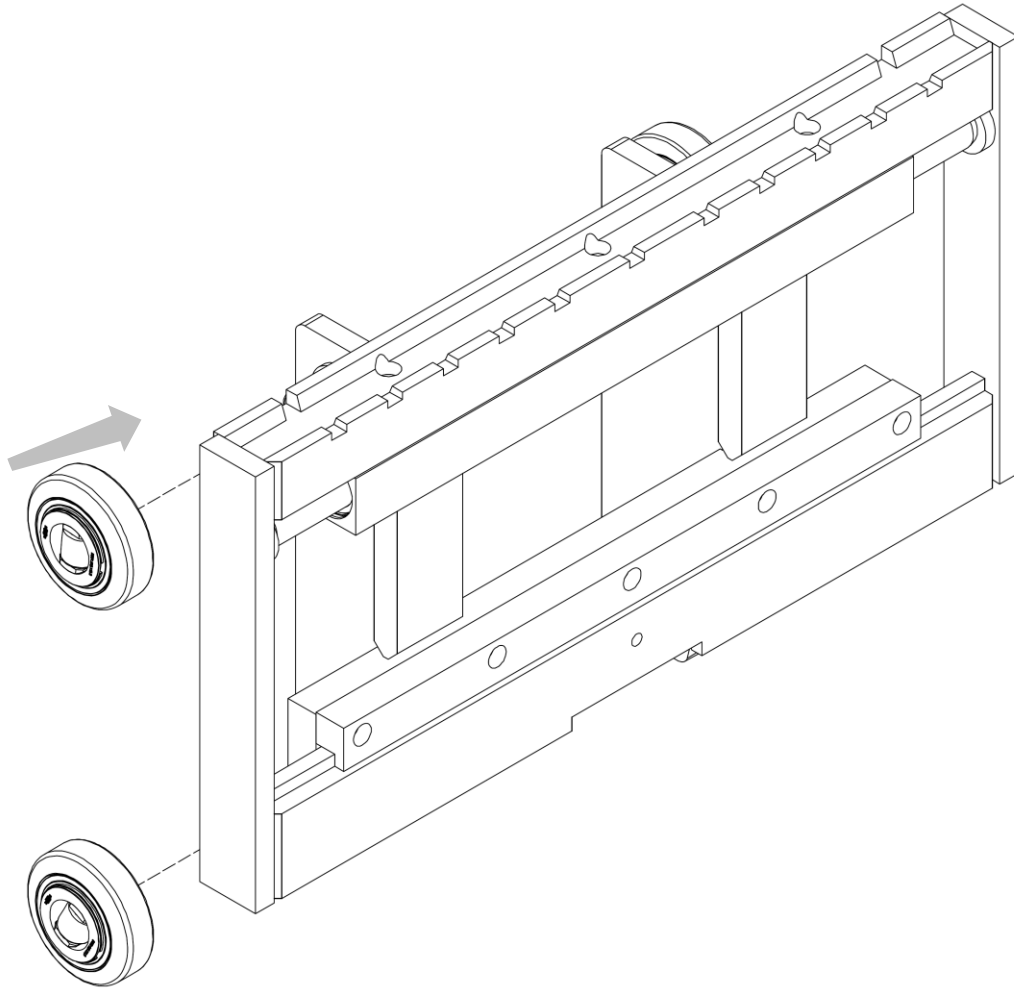

Picture 7

14. Check the condition of the chains and fastening accessories and replace any damaged or worn parts if necessary.

15. Install the equipment in the mast by inserting the rollers in the special sliding guides and fasten the chains in the holes in the sides according to the procedures provided by the manufacturer of the mast (*Picture 8*)

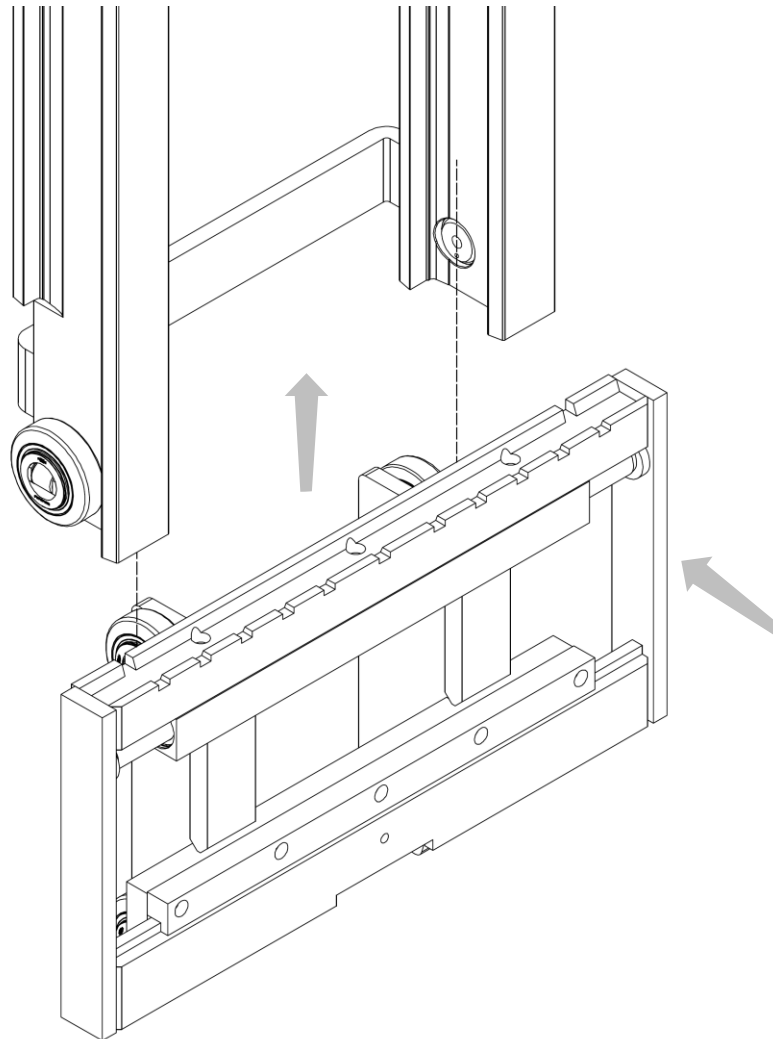

Picture 8

16. Before inserting the forks or any other equipment, unscrew the central screw and then screw it back on once the operation is completed in order not to allow the forks to come out.
17. Connect the sideshifting pipes to cylinder and oil distributor.
18. Making sure that the operating pressure of the pipes is higher than or equal to that indicated on the identification label.
19. Lubricate the contact parts.

3.1.2 Installation the attachment with welded brackets

WELDED BRACKETS

1. Before installation, verify the condition of the fork holding plate, making sure that the lower profile is free of roughness that could compromise the sliding of the lower slides.
2. Also make sure that the profiles of the fork holding plate are not deformed, in order to allow a good coupling with the sideshifting equipment.
3. Sand the lower profile of the fork carriage at the front, clean with detergent and lubricate with graphite grease.
4. Check the condition of the pipes, replacing those that are in a bad condition.
5. Couple the sliding rollers of the mast to the pins made on the brackets (*Picture 9*), in this image, as in the following, bearings, brackets and masts indicated will be purely indicative, with the sole purpose of showing the correct assembly of the equipment.

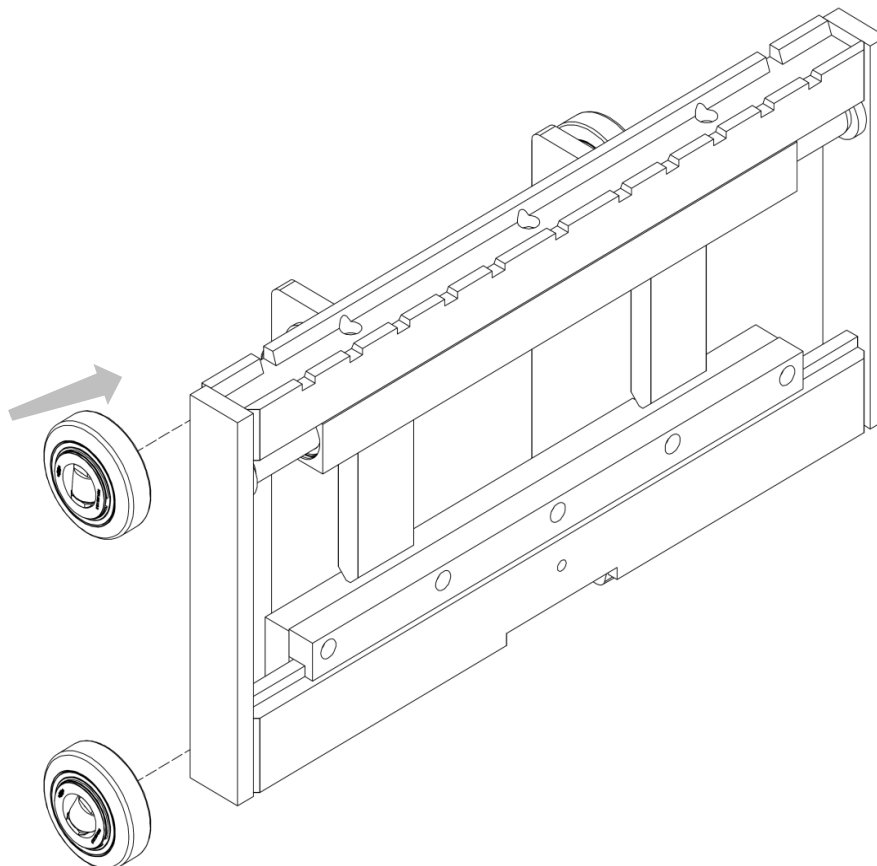

Picture 9

6. Check the condition of the chains and fastening accessories and replace any damaged or worn parts if necessary.

7. Install the equipment in the mast by inserting the rollers into the appropriate sliding guides and fasten the chains in the holes in the brackets according to the methods provided by the mast manufacturer (*Picture 10*).

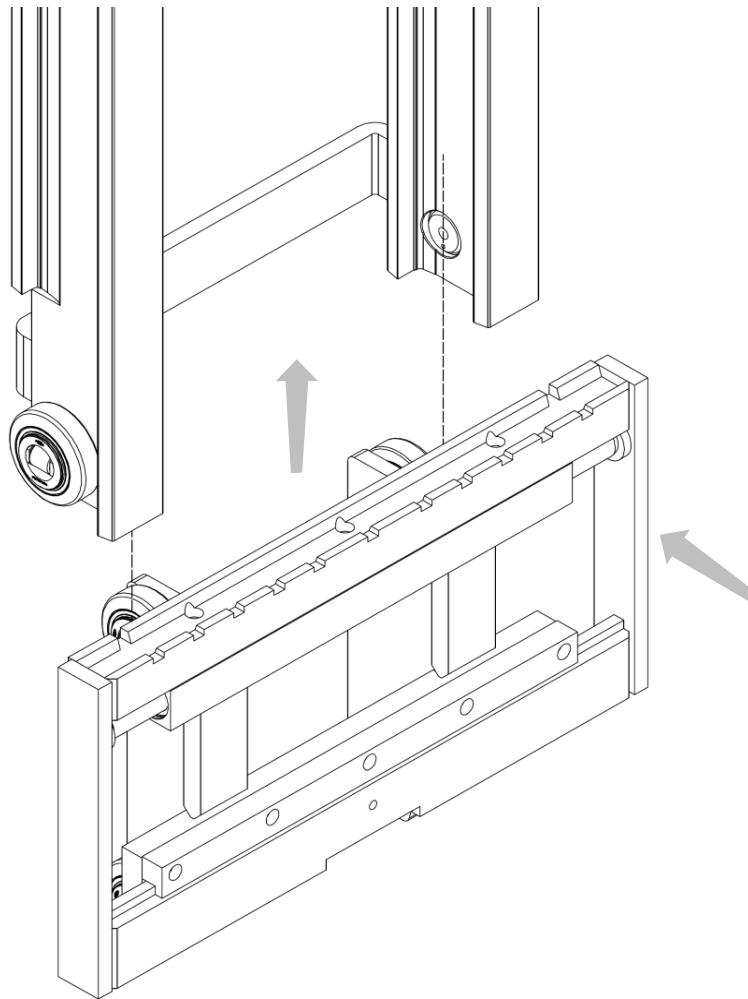

Picture 10

8. Before inserting the forks or any other equipment, unscrew the central screw and then screw it back on once the operation is completed in order not to allow the forks to come out.
9. Connect the sideshifting pipes to cylinder and oil distributor.
10. Making sure that the operating pressure of the pipes is higher than or equal to that indicated on the identification label.
11. Lubricate the contact parts.

4 USE RULES

Before using the equipment, check the tightness of the pipes and the correctness of assembly and connection by performing about ten preliminary operations.

When using the equipment, it is necessary to follow the instructions listed below:

1. Observe the capacity limits of the equipment.
2. Do not use the equipment when people or animals are within the range of action of the forklift.
3. Do not try to lift loads by clamping them between the two forks.
4. Do not try to move loads sideways by sliding them on the ground.
5. Do not exceed the maximum pressure value indicated on the identification plate.
6. Operate the equipment from the driver's seat of the forklift by a single operator.
7. Act gently on the translation control lever, avoiding water hammer as much as possible.
8. Any operation relating to installation, use and maintenance must be performed by specialized personnel equipped with appropriate equipment for the type of intervention to be carried out.
9. Carry out maintenance and / or repair operations with the forklift stopped and with the hydraulic circuit not active, using suitable protective equipment (gloves, safety shoes, etc.).
10. Operate the piston rods only when they are correctly mounted on the equipment; Otherwise, the piston rods could be violently ejected by the oil pressure.

The considered acoustic pressure level is lower than 70 dB (A).

Every ATIB attachments are projected and constructed according to a load positioned (as regards its centre of gravity) at a certain distance from vertical part of the fork.

If you need to increase the distance of the center of gravity as regards vertical part of the fork you have to reduce the weight of the load.

In this occasion, we suggest to control the chart *Picture 11*, where, according to the increase of the centre of gravity (x-axis) there is a load reduction multiplying factor (y-axis).

The multiplying factor, obtained based on desired load centre position, will be multiplied with nominal capacity of the equipment. The result of this multiplication will be actual capacity of the attachment.

Continuous line is for equipment with load center at 500 mm.

Dotted line is for equipment with load center at 600 mm.

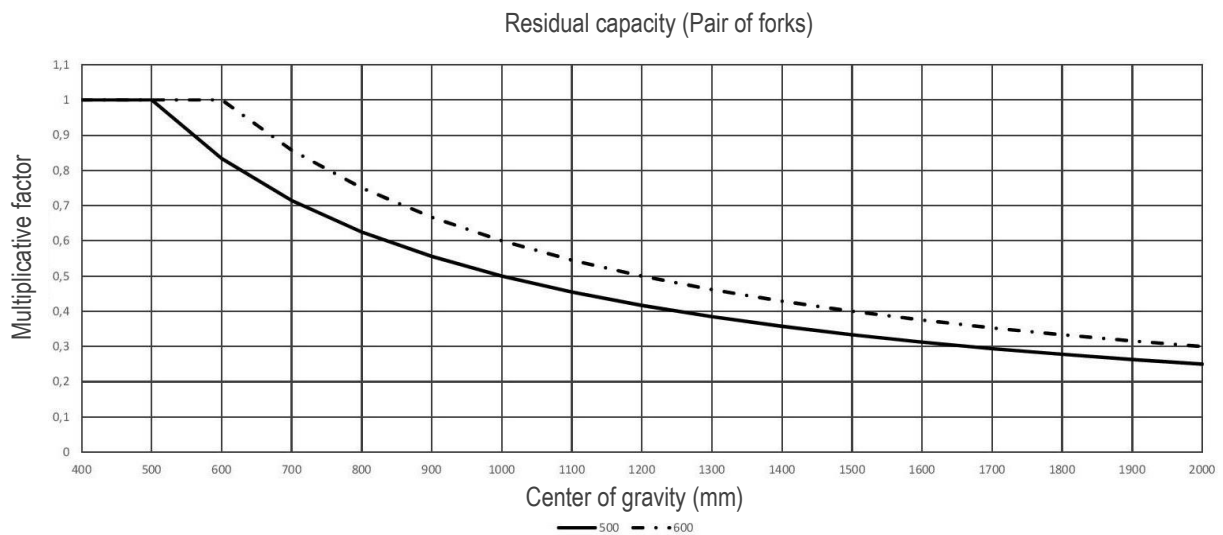

Picture 11

NOTE - This calculation is valid only for "stable" load, in case of movement of liquid material please contact the produce.



To check the nominal capacity of the combination forklift – attachment ask the producer of the forklift.



The condition of the soil, the quickness of the movement of the load and the lifting height can affect the hold of the load and must be taken into consideration as regards specific occasions.



Side shifting movement is forbidden in movement.
Side shifting movement in condition of lifted mast is permitted only to bring back the load at the center of the mast.

Nominal capacity of the combination forklift – attachment is established by the producer of the forklift and can be lower than the one indicated on the identification label of the attachment.

Check label of the forklift (Directive 2006/42/CE).

5 PERIODIC MAINTENANCE

Failure to adhere to the norms and established times for maintenance operations, will be detrimental to the good functioning of the equipment and will annul the guarantee conditions.

All maintenance operations must be carried out with the forklift motionless and the hydraulic circuit not activated, perimeter the entire maintenance area, using the necessary protective devices and, if it is necessary to disassemble the cylinders, always using a tray or container to recover the oil still present in the cylinder itself.

To avoid problems regarding the use of the equipment, A.T.I.B recommends changing the hydraulic oil and its filters regularly and trying to keep the system as clean as possible during maintenance operations.

WARNING!!!

The hydraulic parts can be very hot. Use adequate protections.

Beware of any leaks. Oil under high pressure can damage the eyes and skin. Always wear protective goggles on the sides as well.

Never remove valves, hoses or other potentially pressurized parts when it is active.

5.1 Maintenance every 100 hours

1. Check the conditions of the hydraulic connections (pipes and fittings), replacing, if necessary, the worn parts.
2. Check the tightening torque of the bolts of the lower sealing hooks of the equipment. if necessary, intervene on the tightening of the screws that support them.
3. Clean and lubricate all sliding parts (*point 8.2 pag.25*).

5.2 Maintenance every 300 hours

1. Check the condition of upper and lower sliding devices if an excessively worn component is found, it is recommended to replace the entire assembly of the component in question.
2. Also carry out the operations listed in the previous point (*Point 06.01*).

5.3 Maintenance every 1000 hours

1. Check the condition of upper and lower sliding devices if an excessively worn component is found, it is recommended to replace the entire assembly of the component in question.
2. Also carry out the operations listed in the previous point (*Points 06.01 and 06.02 pag.20*).

5.4 Maintenance every 2000 hours

1. Proceed with a thorough inspection of the equipment; this, possibly, must be performed by qualified personnel, able to identify any problems that could compromise the safety and efficiency of use of the equipment. The defects that can be found can be many:
 - Check the condition of all equipment components (cylinders, hooks, gaskets, fittings, grease nipples, etc.), verifying that their conditions are optimal and, if there are worn components, proceed with their replacement / repair.
 - Check the condition of the sliding and working surfaces and proceed with their replacement / repair if they are damaged.

For further possible problems (and relative solutions) refer also to *Tab 4 pag.24*.

2. Disassemble the cylinders and check the condition of the rods and seals, if there is a damaged or excessively worn seal, it is always recommended to replace the entire assembly seals.
3. Replace the seals even in the event of oil leaks and the rods if scratched (the cylinders must always be tested inserted in the equipment in order to avoid the sudden expulsion of the rods).
4. Also carry out the operations listed in the previous points (*Point 06.01, and points 06.02 06.03 pag.20*).

Please Note: Intensify interventions in case of use in particularly severe conditions

6 DISASSEMBLY PROCEDURE

6.1 Cylinder removal

1. Relieve the pressure of the hydraulic system.
2. Remove the movable frame with belts appropriately sized as indicated in *Picture 3*, pag. 10.
3. Remove the elastic ring **A** and extract the stem **B** which will come out of its seat together with the cap **C**. Then, remove the stem from the cap (*Picture 12*).

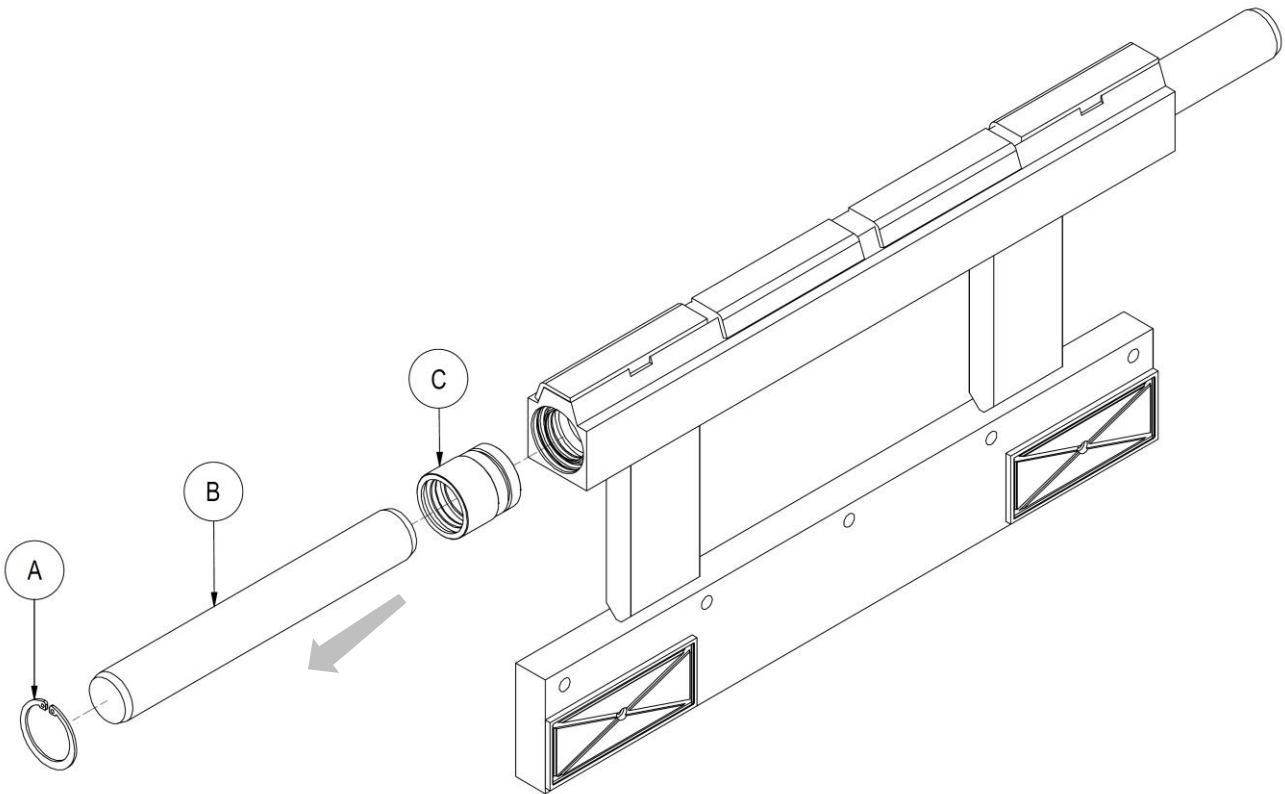

Picture 12

4. Replace the worn seal (*Picture 13*).

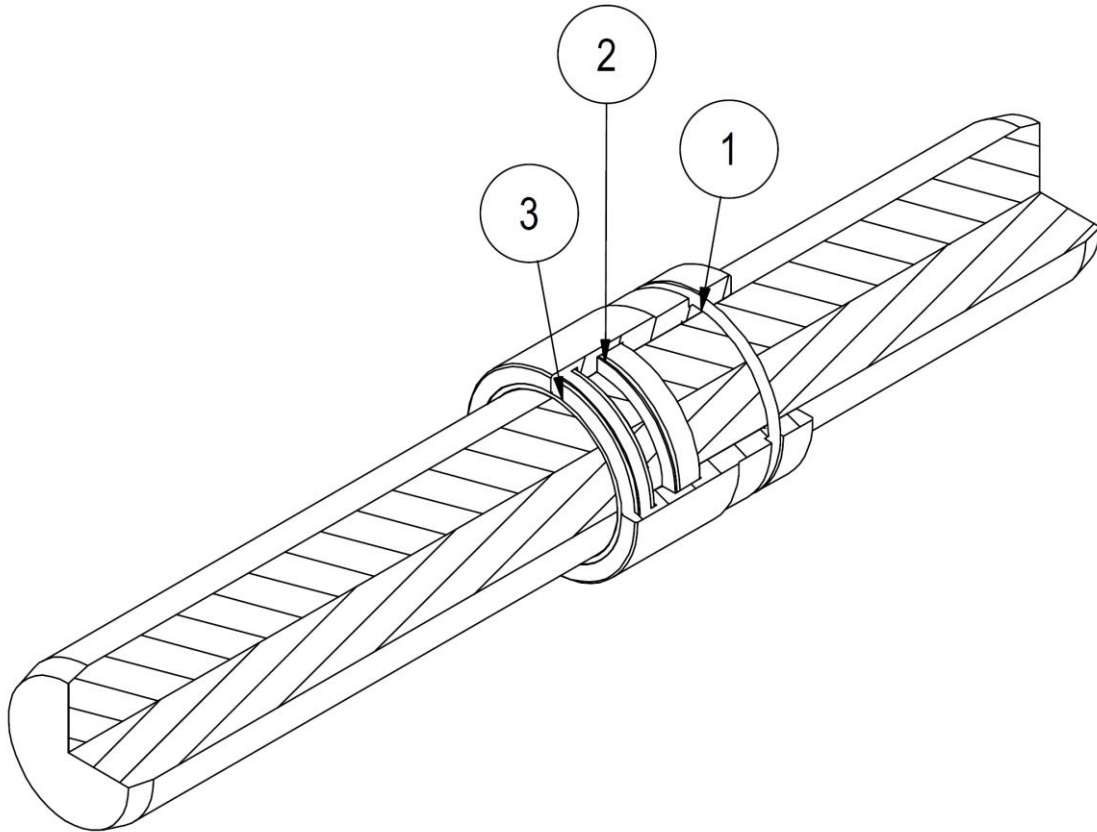

Picture 13

Number	Qty	Code	Descrizione	Description
1	2	A5001103	O-ring	O-ring
2	2	A5111168	Guarnizione	Seal
3	2	A5309035	Raschiatore	Scraper ring

Tab 3

5. Reassembly the cylinder, follow the previous steps in backwards.

7 BREAKDOWNS AND SOLUTIONS

7.1 Breakdowns and solutions

FAILURE	CAUSE	SOLUTION
	Low oil flow	Check the tank level and the pump
		Bottlenecks in the system: Search and delete them
	Mechanical deformations of some parts	Repair or replace
Irregular side shift	Worn cylinder seals	Replace
	Presence of air in the hydraulic system	Bleed the hydraulic system
	Worn slide parts	Replace
	Excessive friction between the sliding parts	Clean and lubricate the sliding parts
	Worn cylinder seals	Replace
	Lack of oil in the tank	Top up

Tab 4

Should there be other problems, please contact A.T.I.B. S.r.l.

7.2 Lubricate

1. Lubricate the sliding parts using the special grease nipples (*Picture 14*).
2. Lubricate the slide and relative scroll bar (*Picture 14*).

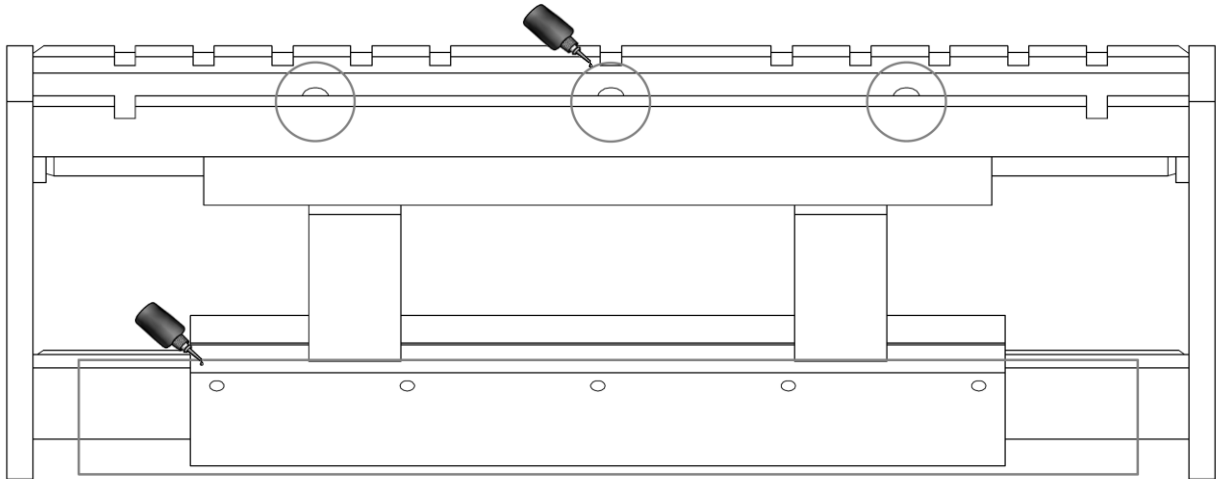

Picture 14

A.T.I.B. S.r.l.
Via Quinzanese snc, 25020 Dello (BS) - ITALY

+39 030 977 17 11

info@atib.com

atib.com

