



ATiB MATERIAL
HANDLING

INSTRUCTIONS MANUAL FOR USE

DOUBLE FORK POSITIONER TYPE 917

TRIPLE FORK POSITIONER TYPE 918

INDEX

DOUBLE FORK POSITIONER TYPE 917 TRIPLE FORK POSITIONER TYPE 918



READ THIS MANUAL VERY CAREFULLY BEFORE STARTING-UP THE MACHINE

INDEX	1
1 SAFETY RULES	3
2 INTRODUCTION	4
2.1 Use and upkeep of this manual	4
2.2 Description of the equipment.....	5
3 INSTALLATION	9
3.1 Installation	10
3.1.1 Attachment Installation - TYPE 917.T2/T4 and 918.T	10
3.1.2 Attachment Installation – TYPE 917.2/4 e 918	15
3.2 Fork Installation	18
4 HYDRAULIC SYSTEM	19
4.1 HYDRAULIC SYSTEM – TYPE 917.T2/T4 and 918.T	19
4.2 Hydraulic System – TYPE 917.2/4 and 918.....	20
5 USE RULES	21
6 PERIODIC MAINTENANCE	24
6.1 Maintenance Every 100 Hours	24
6.2 Maintenance Every 300 Hours	24
6.3 Maintenance Every 1000 Hours	25
6.4 Maintenance Every 2000 Hours	25
7 DISASSEMBLY PROCEDURE	26
7.1 Disassembly attachments from forklift	26
7.2 Forks disassembly.....	27
7.3 Fork cylinders removal from attachments	28
7.3.1 Disassembly and reassembly of the fork cylinders.....	29
7.4 Gas spring removal from attachment.....	30
7.4.1 Disassembly and reassembly of the gas spring	32

7.5	SLS cylinder removal from attachment.....	33
7.5.1	Disassembly and reassembly SLS cylinder	34
7.5.2	SLS Sideshift Bushing Maintenance.....	35
8	BREAKDOWNS AND SOLUTIONS.....	36
8.1	Breakdowns and solution.....	36
8.2	Lubrication	37

1 SAFETY RULES



Don't carry passengers



Don't cross the mast



Don't pass under the load

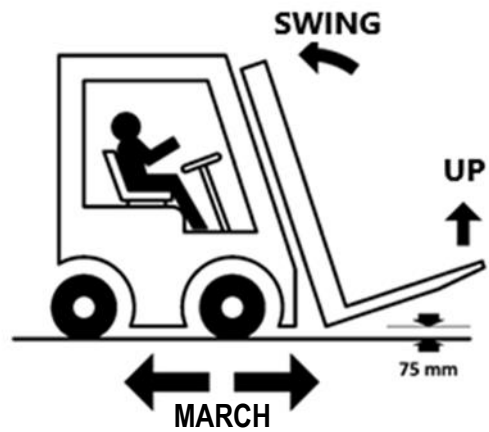

2 INTRODUCTION

2.1 Use and upkeep of this manual

This "User Manual" (hereinafter referred to as Manual) is supplied together with the A.T.I.B. - DOUBLE FORK POSITIONER TYPE 917 TRIPLE FORK POSITIONER TYPE 918 pursuant the CE DIRECTIVE 2006/42/CE date 17/05/2006 and amendments.

The information contained here are imperative for the correct use of the attachment and must be known by the personnel who install, use, maintain and repair it.

This manual must be considered integral part of the attachment and must be kept as long as the attachment is in use on any machine in an accessible place, protected, dry and available for immediate consultation.

Should this manual be lost, the operator can apply for the supply of further copies from the manufacturer.

The manufacturer reserves the right to modify this Manual without notice and without the obligation to update the copies previously distributed.

The manufacturer is not liable in cases of:

- improper use of the attachment;
- use by untrained personnel;
- use contrary to current national and international laws;
- lack of recommended maintenance;
- non authorised modifications and repairs;
- use of non-original spare parts or parts for other models;
- failure to adhere, either totally or partially, to these instructions;
- exceptional circumstances.

The Nominal Capacity of the forklift / Equipment combination is established by the original manufacturer of the forklift and may be lower than that indicated on the identification plate.

Consult the plate of the forklift (Directive 2006/42 / EC).

2.2 Description of the equipment

TYPE 917.T2

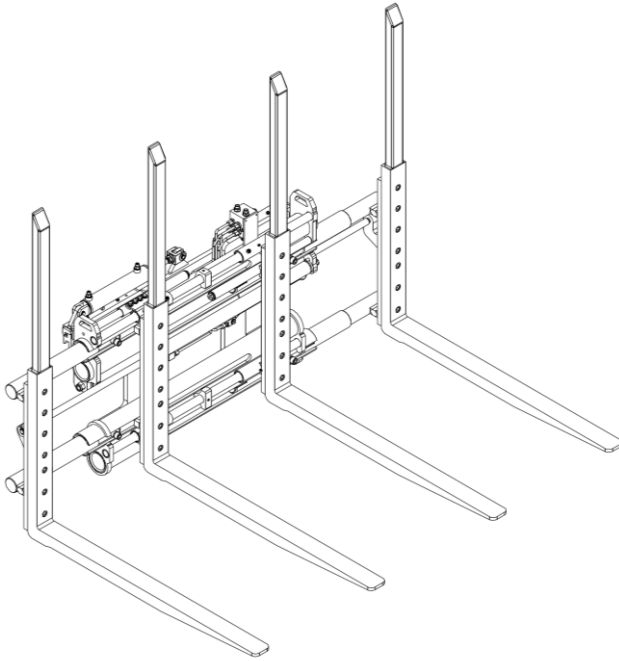

TYPE 917.T4

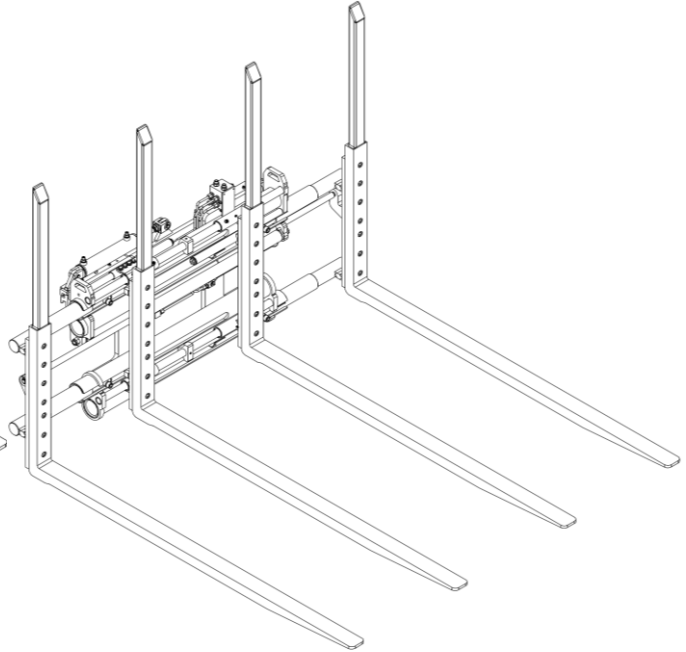

TYPE 917.2

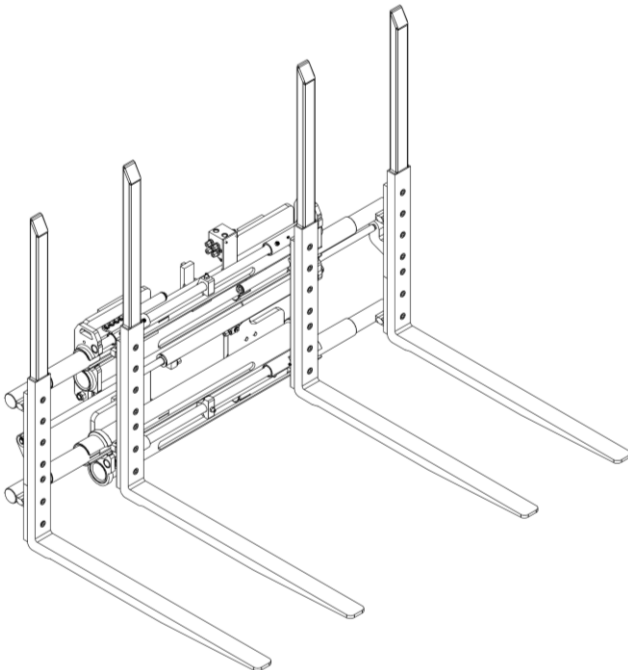

TYPE 917.4

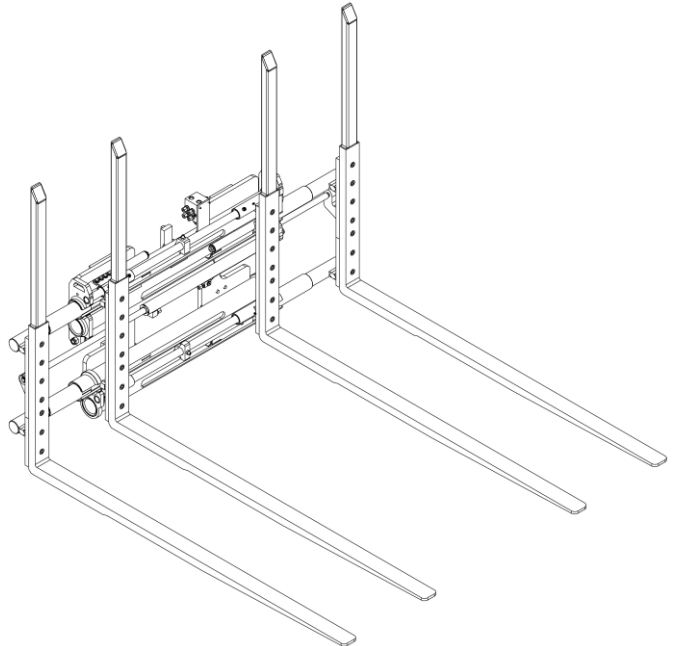

TYPE 918.T

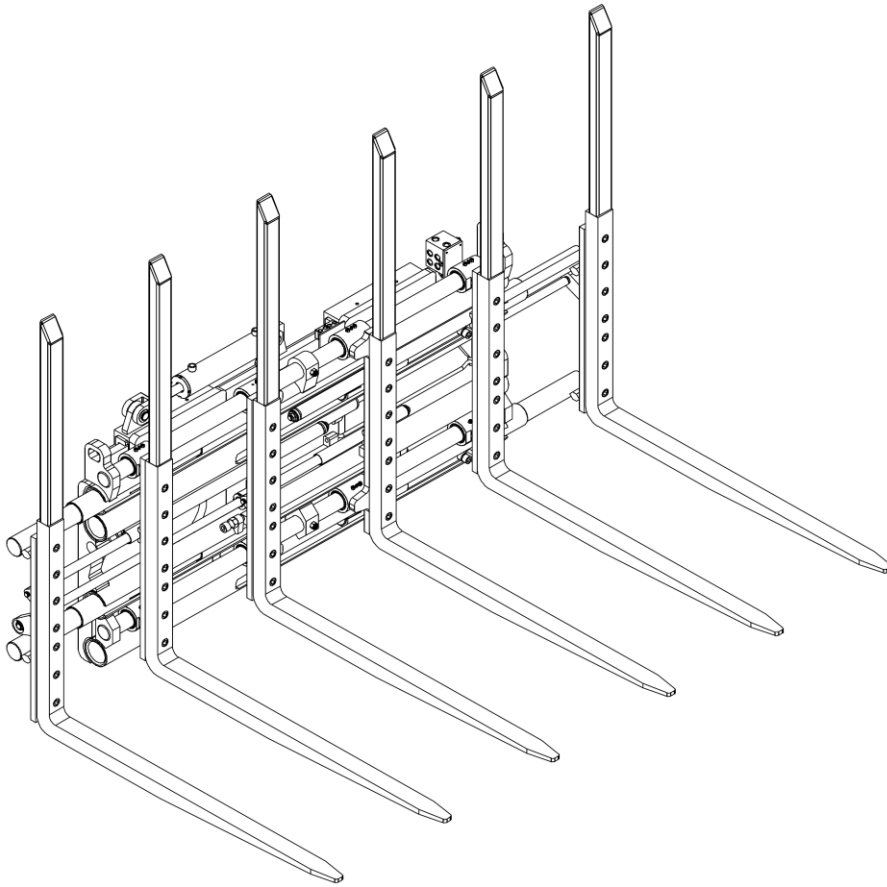

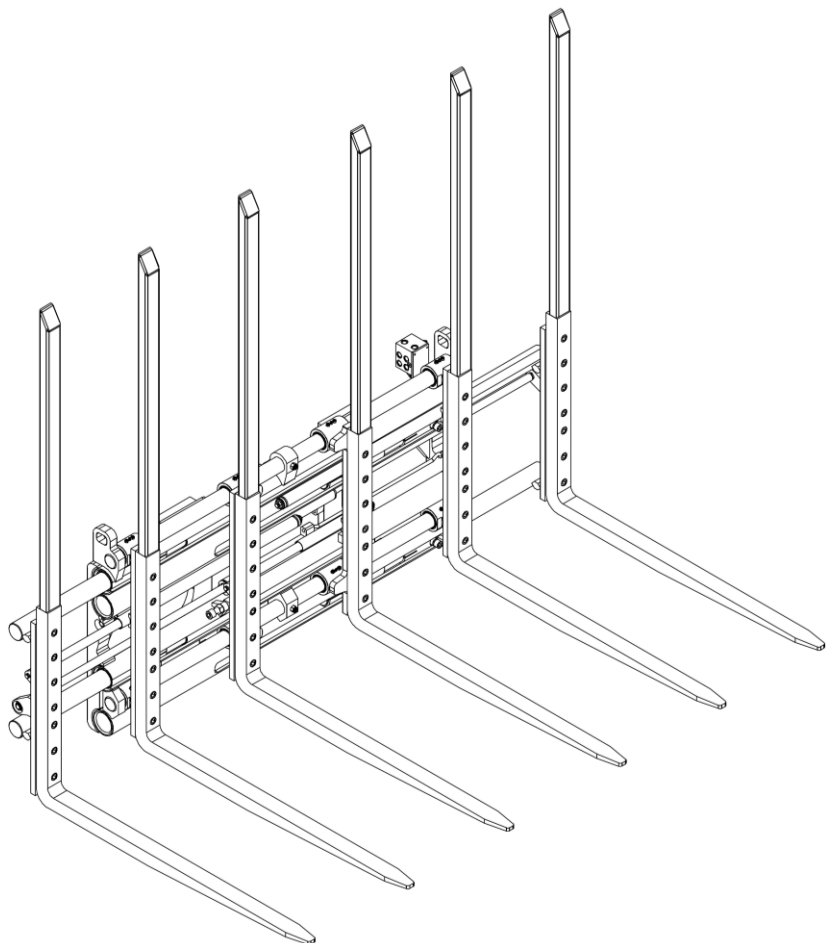

TYPE 918

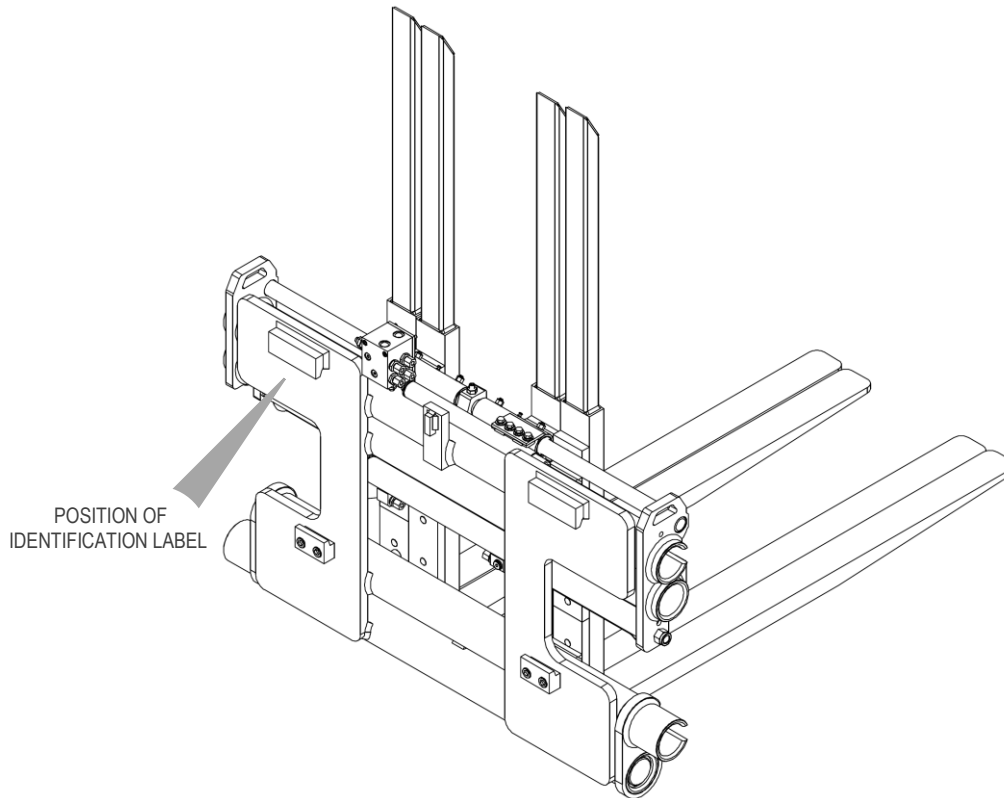

All the A.T.I.B. - DOUBLE FORK POSITIONER TYPE 917 TRIPLE FORK POSITIONER TYPE 918 equipment are identified by means of a sticky identification label (*Tab. 1*) position of identification label on equipment (*Picture 1*; for all types, the position of the identification plate is the same as shown in the figure), always refer to the serial number.



Picture 1

1. TYPE	8. NOMINAL CAPACITY	kg/mm	11. MAX. TORQUE	daN m
2. CODE	9. CLAMPING CAPACITY	kg/mm	 	A.T.I.B. S.r.l. Via Quinzanese snc, 25020 Dello (BS) - ITALIA +39 030/9771711 info@atib.com - atib.com
3. SERIAL N°				
4. YEAR OF MANUFACTURE	10. MAX. OPERATING PRESSURE	bar		
5. WEIGHT				
6. THICKNESS	WARNING: RESPECT THE RATED CAPACITY OF TRUCK AND ATTACHMENT COMBINED			
7. CENTER OF GRAVITY				

Tab. 1

1. **TYPE**
It identifies the model of the equipment as shown in the catalogue.
2. **CODE**
It identifies the equipment order code.
3. **SERIAL N°**
It progressively identifies the individual equipment.
The series number has been stamped should the tag go missing or be damaged. Always refer to the series number for any kind of information.
4. **YEAR OF CONSTRUCTION**
It indicates the year of construction.
5. **WEIGHT**
It indicates the Q weight of the equipment in kg.
6. **THICKNESS**
It indicates the thickness of the equipment in mm.
7. **CENTER OF GRAVITY**
It indicates the distance in mm of the equipment CG center of gravity from the fork holding plate table.
8. **NOMINAL CAPACITY**
It indicates the maximum P load applicable to the hoisting equipment and the maximum CC barycentric distance of the load itself.
9. **CLAMPING CAPACITY**
Not applicable to this equipment.
10. **MAX OPERATING PRESSURE**
It indicates the maximum pressure applicable to the equipment.
11. **MAX COUPLE**
Not applicable to this equipment.

The A.T.I.B. - DOUBLE FORK POSITIONER TYPE 917 TRIPLE FORK POSITIONER TYPE 918 were planned and built to allow the transportation and, if requested, the side shifting, of 1, 2 or 3 pallets with the possibility to modify the opening range of the internal and external Forks of the Attachment itself.

T = Sideshift semi-integrated

917.2/.T₂ = To transport of 1 o 2 pallets.

917.4/.T₄ = To transport of 1-2-4 pallets (longer forks)

This attachment is designed to be applied to the fork carriage of forklift trucks and connected with hydraulic circuit via to the hydraulic distributor.

Safety components are manufactured to ISO Standard 2328.

3 INSTALLATION

Verify the nominal capacity of equipment

To check the nominal capacity of equipment, consult the identification label (*Tab. 1 pag. 7*).



Make sure that the operator of the forklift is aware of the maximum capacity of the attachments, so as **NOT** to pose a danger to himself and to the people who work in his vicinity.

The forklift truck manufacturer is responsible for calculating the residual capacity of the forklift /equipment assembly.

Check operation pressure and flow rate of oil

A.T.I.B. advises to respect the hydraulic flow rates and operating pressures shown in *Tab. 2*, in order to optimize the operation of the equipment and avoid problems during the work or commissioning phases. The values are indicative and may vary depending on the equipment.

TYPE and ISO	PORTATA (l/mm)			Max. operating pressure (Bar)
	Min.	Max.	recommended	
917.T2 ALL [II & III]	30/ 10	50/ 20	45/ 15	200
917.T4 ISO III	30/ 10	50/ 20	45/ 15	200
917.T4 ISO IV	30/ 15	50/ 25	45/ 20	200
917.2 ALL [II & III]	30	50	45	200
917.4 ISO III	30	50	45	200
917.4 ISO IV	30	50	45	200
918.T ALL [III]	30/ 15	50/ 25	45/ 20	200
918 ALL [III]	30	50	45	200

Tab. 2

values in bold refer to sideshift.



RESPECT THE MAXIMUM WORKING PRESSURES INDICATED

3.1 Installation

3.1.1 Attachment Installation - TYPE 917.T2/T4 and 918.T

TYPE 917.T2/T4 E

1. **Before installation**, verify the condition of the fork carriage, ensuring that it is not deformed.
2. Also make sure that the profiles of the fork holding plate are not deformed, in order to allow a good coupling with the equipment.
3. Check the condition of the pipes, replacing those that are in a bad condition.

NOTE: although in the following figures only the 917.T2 type is represented, the installation method is the same also for 917.T4 and 918.T.

4. Remove the two pins, with the relative snap rings, which lock the semi-integral sideshift cylinder (*Picture 2*).

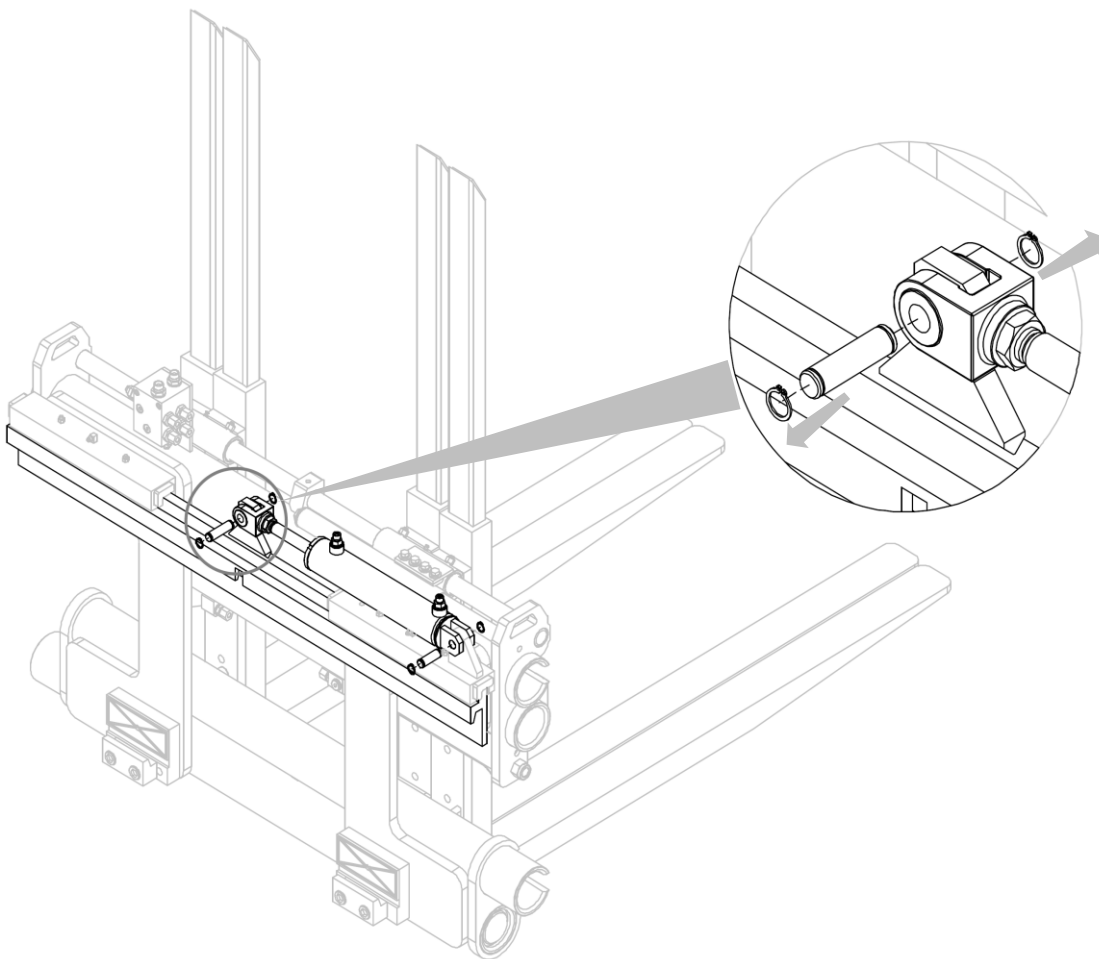

Picture 2

5. After the shifting cylinder has been removed, manually take the double hook A, and place it on the upper profile of the fork carriage, placing the centring tooth C into the central notch (*Picture 3*).

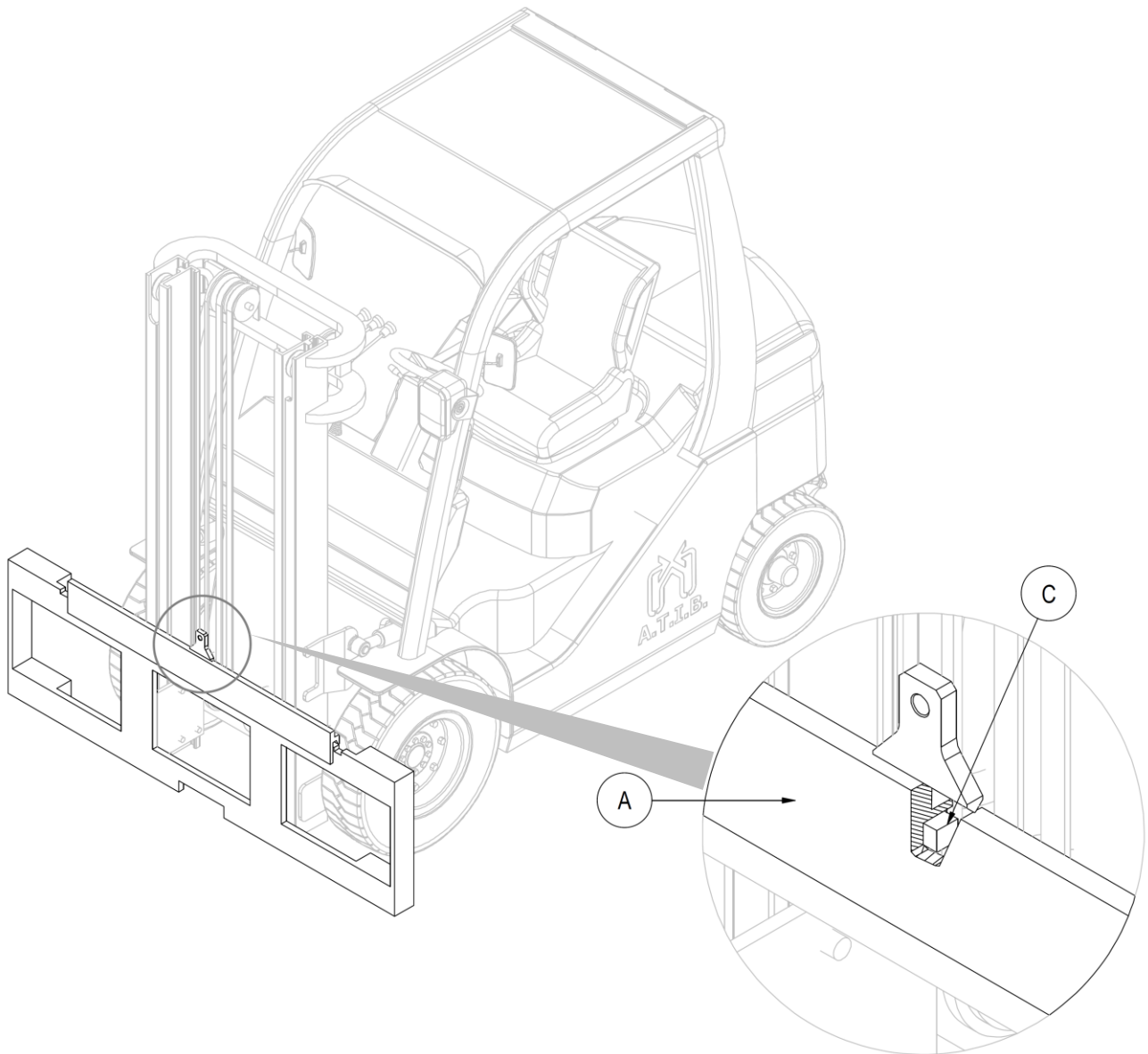

Picture 3

6. Unscrew the lower hooks of equipment and lubricate the slide (*Picture 4*).

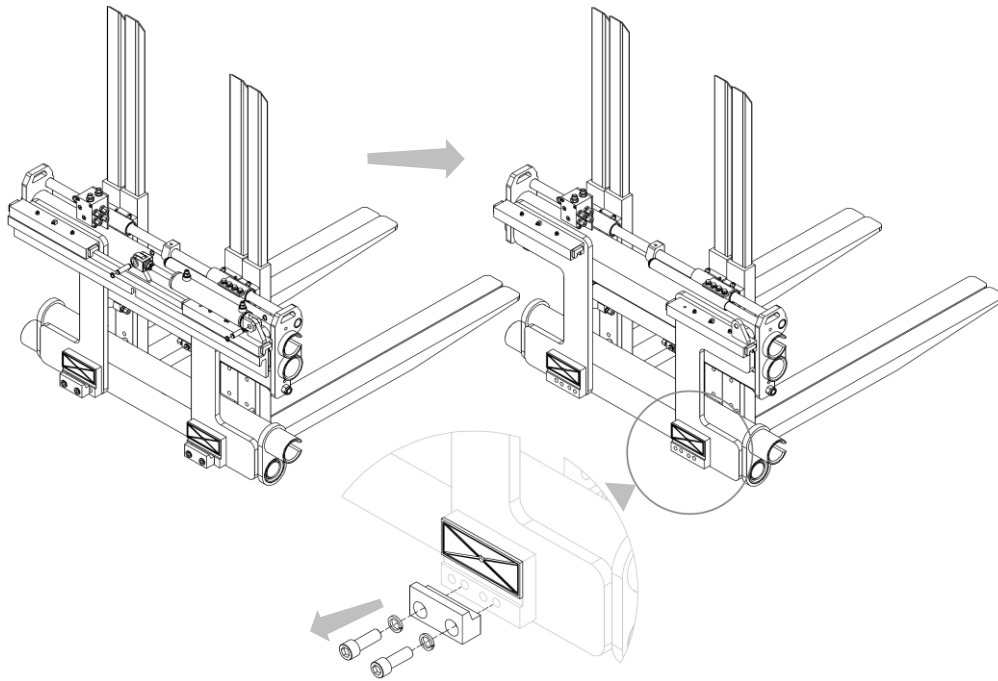

Picture 4

7. For handling, use belts or chains appropriately sized for the weight of the equipment, indicated on the identification plate (*Picture 1* and *Tab. 1* pag. 7).
8. with an overhead crane or with a hoist of sufficient capacity hook the attachment on the double hook, taking care to position the equipment correctly (*Picture 5*).

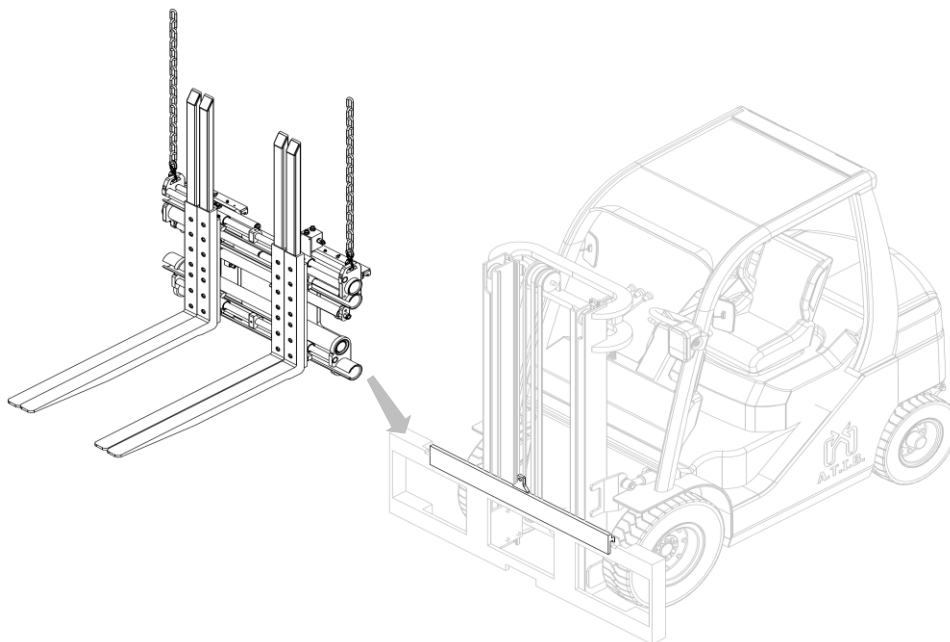

Picture 5

9. Reposition the SLS cylinder using the previously removed pins and elastic rings (*Picture 6*).

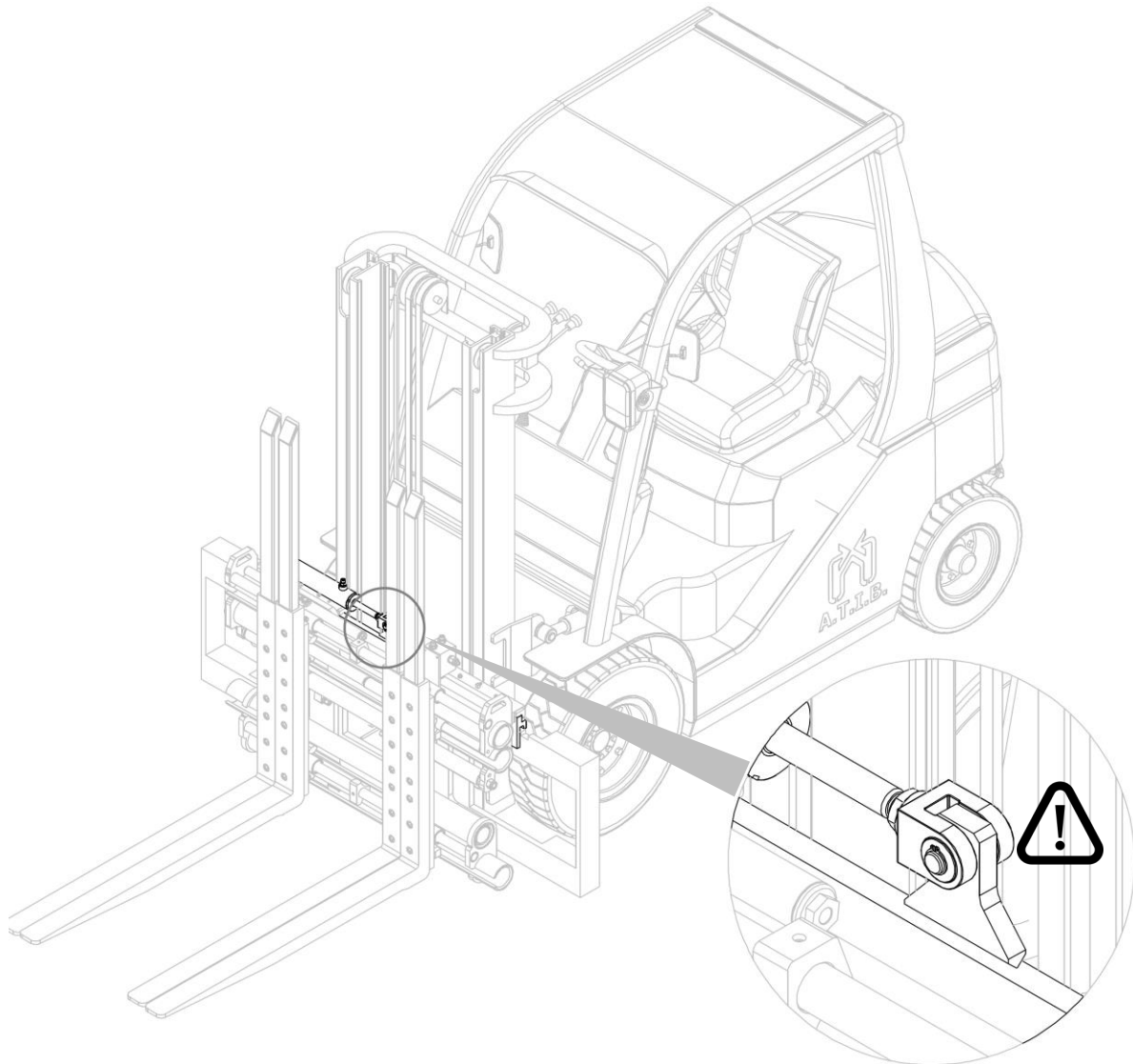

Picture 6

10. Screw the two bottom hooks G with bolts so that the attachment is safely mounted on the fork carriage P (with a tolerance max. 1,5mm, *Picture 7*), reaching to the following torques *Tab. 3*.

ISO 2328	THREAD	TORQUE
ISO II	M12	90 Nm
ISO III	M14	140 Nm
ISO IV	M16	220 Nm

Tab. 3

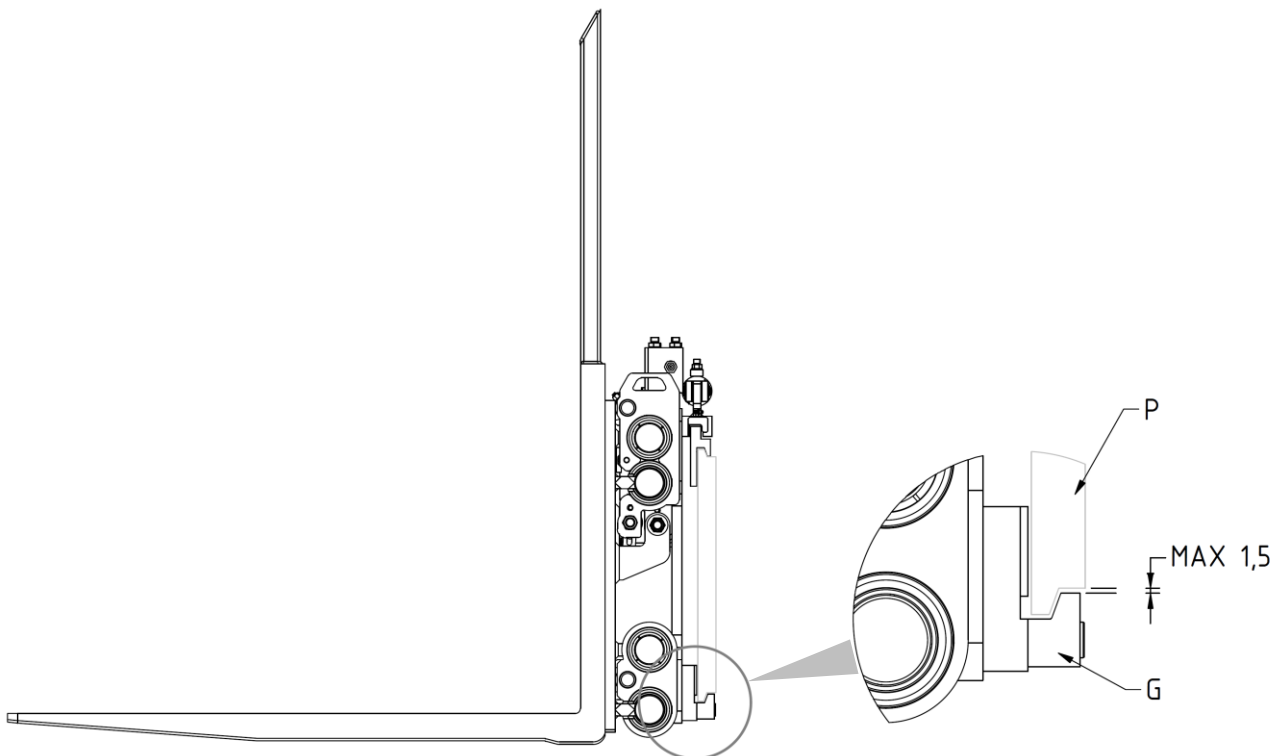

Picture 7

11. Lubricate the contact parts.
12. Connect the hydraulic circuit; making sure that the operating pressure of the pipes is higher than or equal to that indicated on the identification label (*Picture 1* and *Tab. 1* pag.7).

3.1.2 Attachment Installation – TYPE 917.2/4 e 918

TYPE 917.2/4 E 918

1. Before installation, verify the condition of the fork holding plate, ensuring that it is not deformed.

2. Also make sure that the profiles of the fork holding plate are not deformed, in order to allow a good coupling with the equipment.
3. Check the condition of the pipes, replacing those that are in a bad condition.

NOTE: although in the following figures only the 917.T2 type is represented, the installation method is the same also for 917.4 and 918.

4. Unscrew the lower hooks of equipment (*Picture 8*).

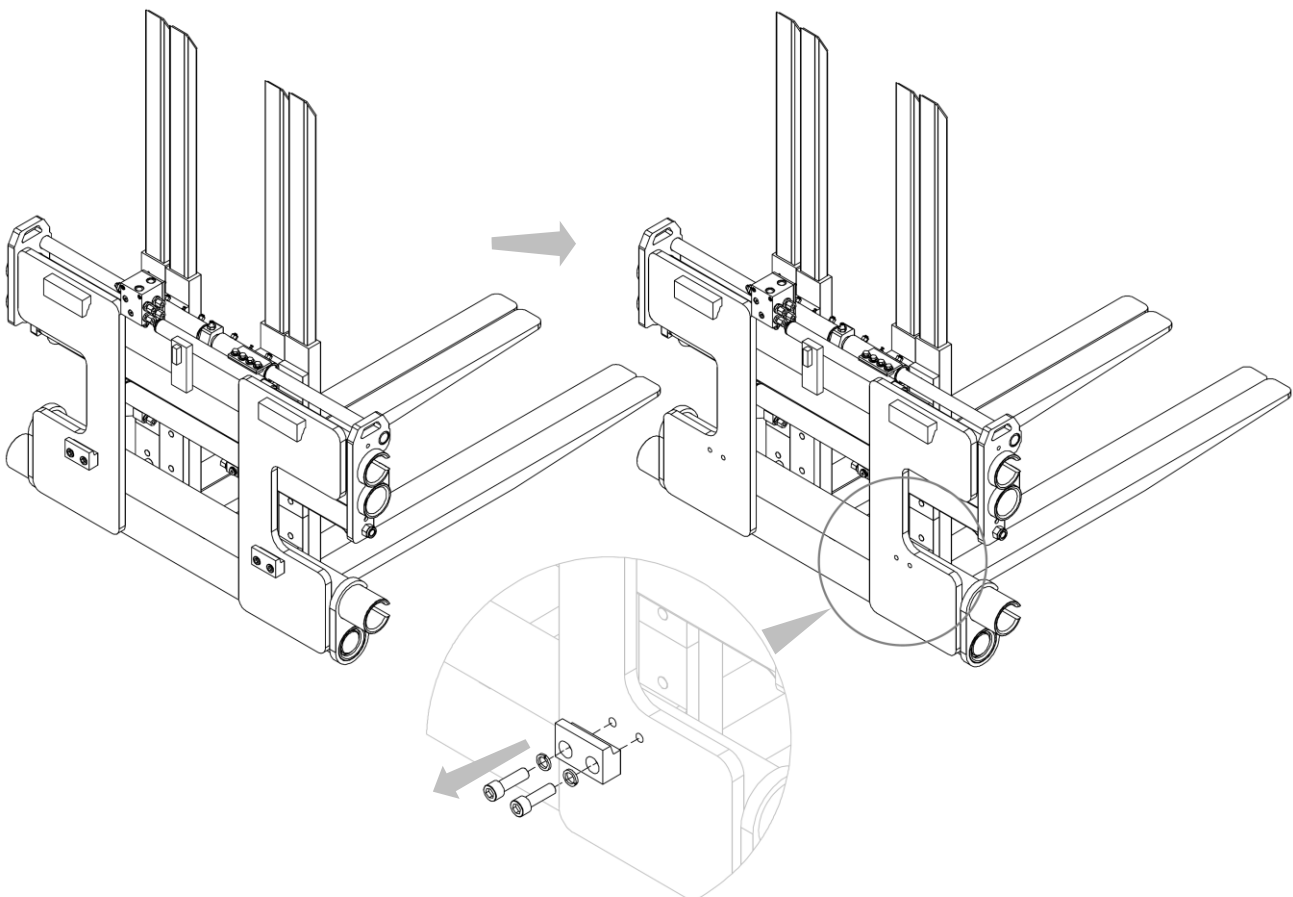

Picture 8

5. For handling, use belts or chains appropriately sized for the weight of the equipment, indicated on the identification plate (*Picture 1* and *Tab. 1* pag. 7).

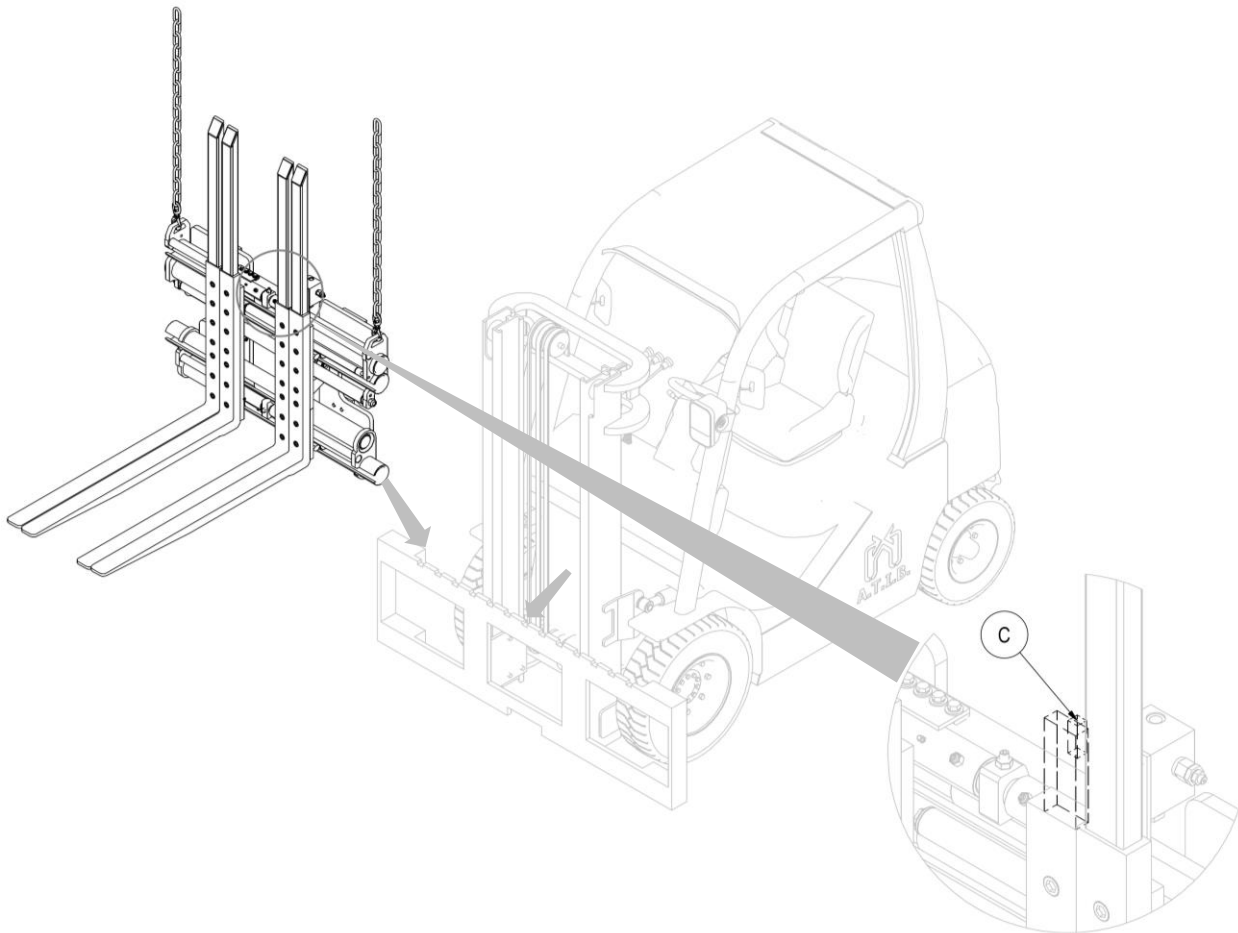

Picture 9

6. with an overhead crane or with a hoist of sufficient capacity hook the attachment to the fork carriage, placing the centring tooth C into the central notch (*Picture 9*).

7. Screw the two bottom hooks **G** with bolts so that the attachment is safely mounted on the fork carriage **P** (with a tolerance max. 1,5mm, *Picture 10*), reaching to the following torques *Tab. 4*.

ISO 2328	THREAD	TORQUE
ISO II	M12	90 Nm
ISO III	M14	140 Nm
ISO IV	M16	220 Nm

Tab. 4

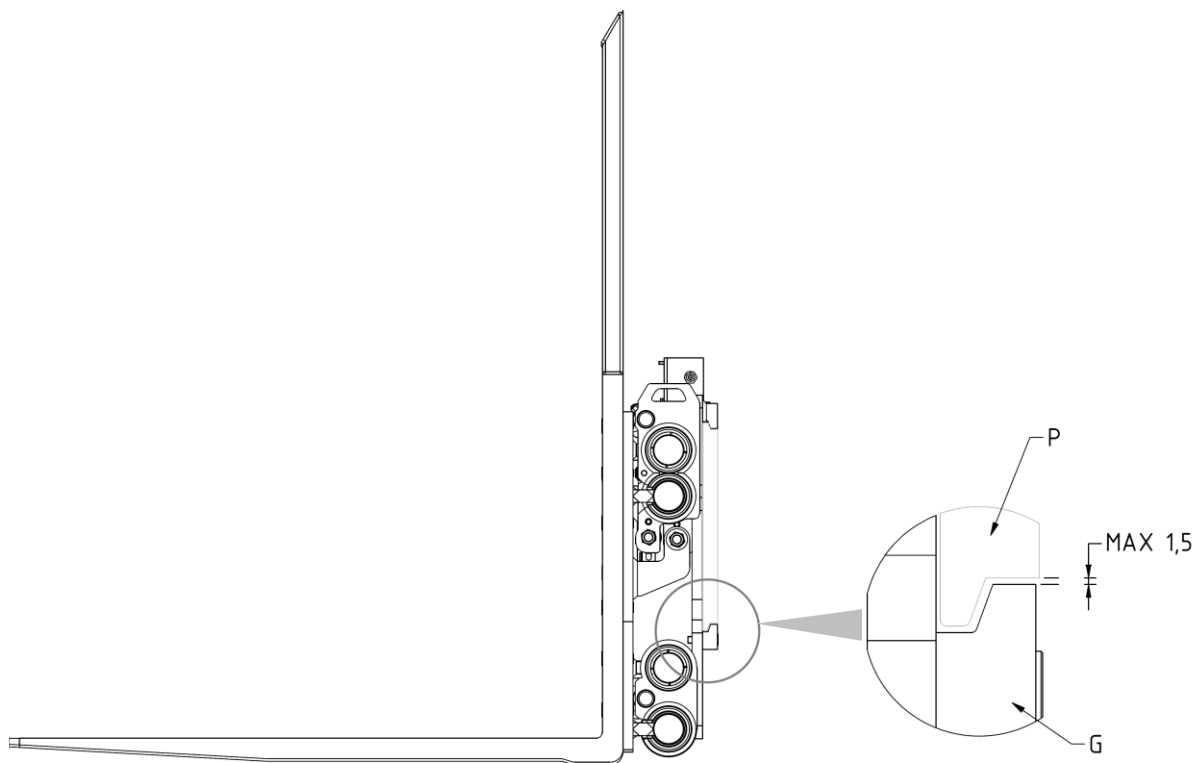

Picture 10

8. Lubricate the contact parts.
9. Connect the hydraulic circuit; making sure that the operating pressure of the pipes is higher than or equal to that indicated on the identification label (*Picture 1* and *Tab. 1* pag. 7).

3.2 Fork Installation

NOTE: the forks are the same for all type of attachments, therefore the installation procedure is the same.

1. Apply the forks on fork holder, screw the relative screws (*Picture 11*).

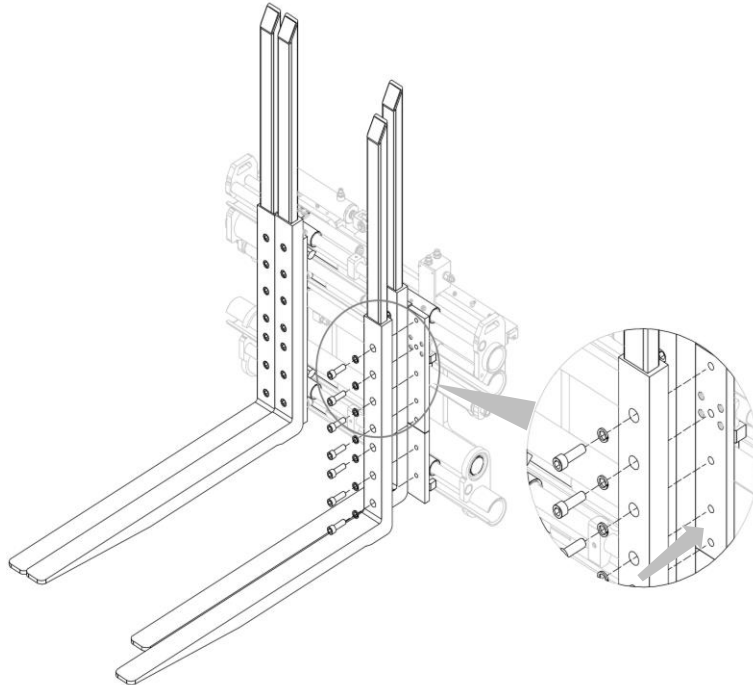

Picture 11

2. Check that the forks are locked correctly (*Picture 12*).

NOTE: the torque of screws (M16) of fork is 170Nm.

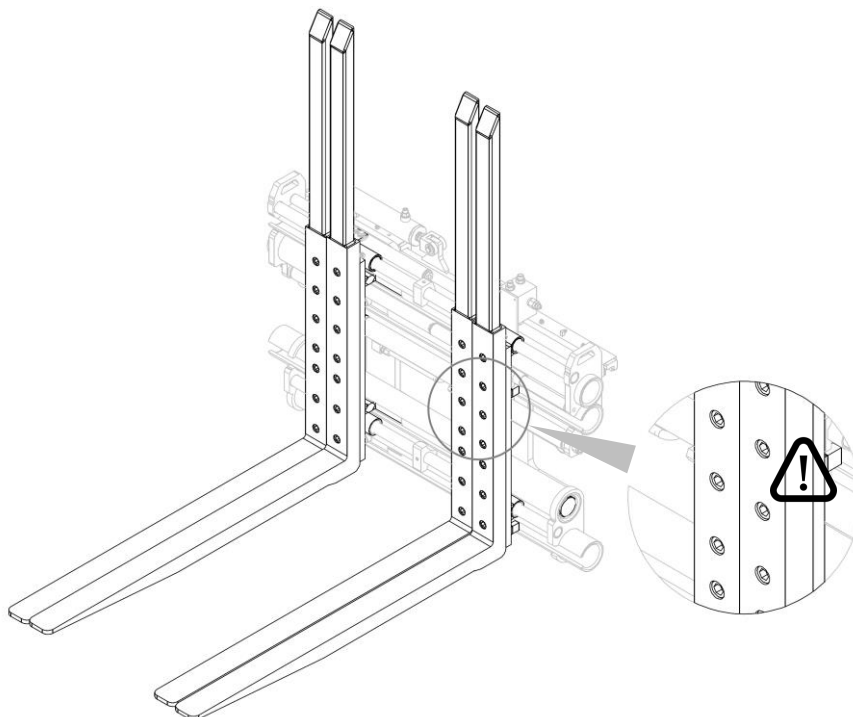

Picture 12

4 HYDRAULIC SYSTEM

4.1 HYDRAULIC SYSTEM – TYPE 917.T2/T4 and 918.T

TYPE 917.T2/T4 - 918.T

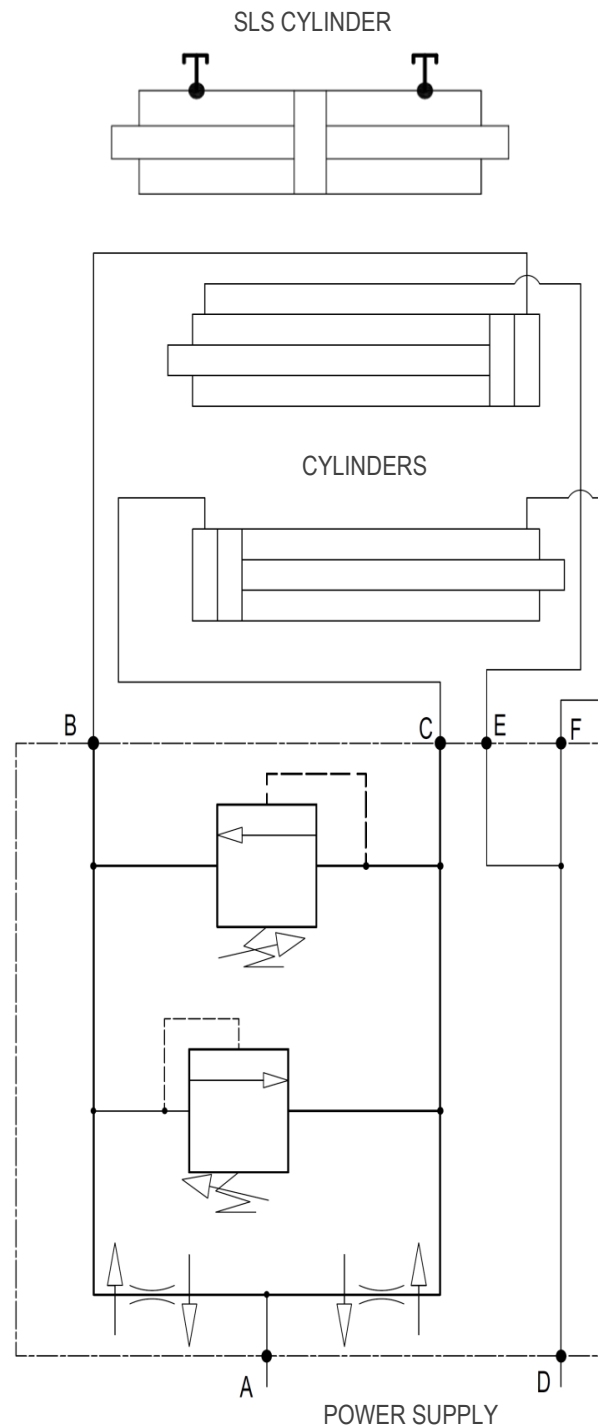

Picture 13

4.2 Hydraulic System – TYPE 917.2/4 and 918

TYPE 917.2/4 - 918

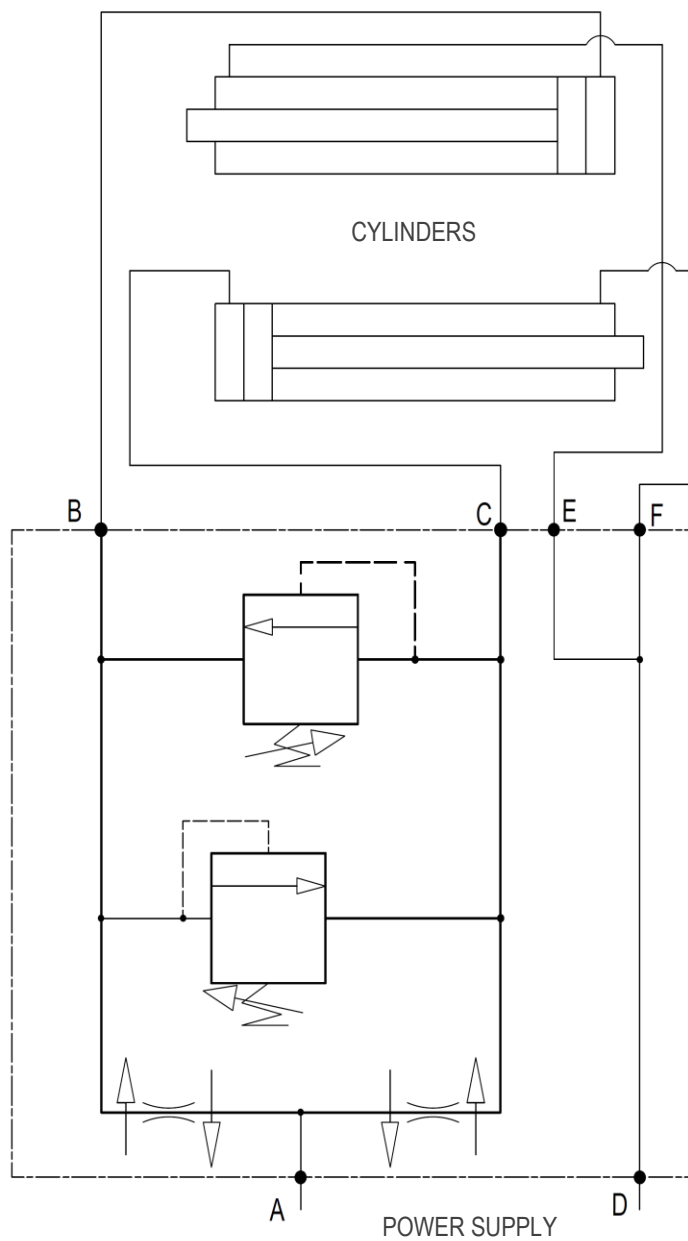

Picture 14

5 USE RULES

Before using the equipment, check the tightness of the pipes and the correctness of assembly and connection by performing about ten preliminary operations.

When using the equipment, it is necessary to follow the instructions listed below:

1. Observe the capacity limits of the equipment.
2. Do not use the equipment when people or animals are within the range of action of the forklift.
3. Do not try to lift loads by clamping them between the two forks.
4. Do not try to move loads sideways by sliding them on the ground.
5. Do not exceed the maximum pressure value indicated on the identification plate.
6. Operate the equipment from the driver's seat of the forklift by a single operator.
7. Act gently on the translation control lever, avoiding water hammer as much as possible.
8. Any operation relating to installation, use and maintenance must be performed by specialized personnel equipped with appropriate equipment for the type of intervention to be carried out.
9. Carry out maintenance and / or repair operations with the forklift stopped and with the hydraulic circuit not active, using suitable protective equipment (gloves, safety shoes, etc).
10. Operate the piston rods only when they are correctly mounted on the equipment; Otherwise, the piston rods could be violently ejected by the oil pressure.

The considered acoustic pressure level is lower than 70 dB (A).

Should the equipment be subject to slight errors in the movement synchronism between the two forks, these movement differences, which will add up in time, will have to be annulled by an operator.

It will be sufficient for the operator to keep one of the two forks at the opening or closing end stroke, for the necessary time it will take for the other fork to recuperate the difference in movement accumulated.

Every ATIB attachments are projected and constructed according to a load positioned (as regards its centre of gravity) at a certain distance from vertical part of the fork.

If you need to increase the distance of the center of gravity as regards vertical part of the fork you have to reduce the weight of the load.

In this occasion, we suggest to control the chart (*Picture 15*) where, according to the increase of the centre of gravity (x-axis) there is a load reduction multiplying factor (y-axis). The multiplying factor, obtained based on desired load centre position, will be multiplied with nominal capacity of the equipment. The result of this multiplication will be actual capacity of the attachment.

Continuous line is for equipment with load center at 500 mm.

Dotted line is for equipment with load center at 600 mm.

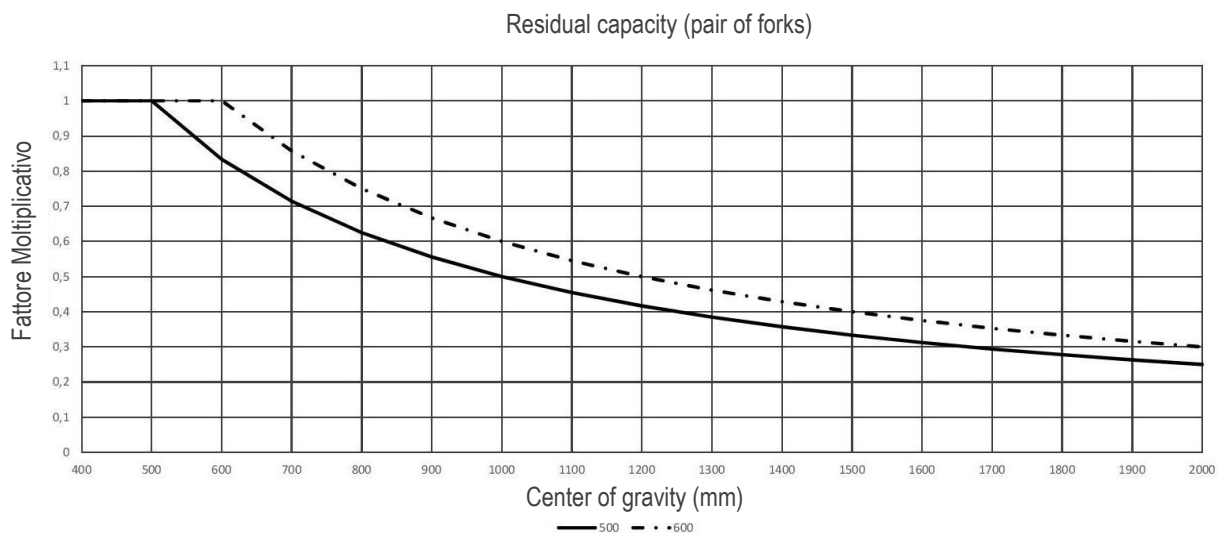

Picture 15

NOTE - This calculation is valid only for "stable" load, in case of movement of liquid material please contact the producer.



The affordable stroke can compromise the stability of the forklift.



To check the nominal capacity of the combination forklift - attachment ask the producer of the forklift.



The condition of the soil, the quickness of the movement of the load and the lifting height can affect the hold of the load and must be taken into consideration as regards specific occasions.



Side shifting movement is forbidden in movement.

Side shifting movement in condition of lifted mast is permitted only to bring back the load at the center of the mast.

Nominal capacity of the combination forklift - attachment is established by the producer of the forklift and can be lower than the one indicated on the identification label of the attachment.

Check label of the forklift (Directive 2006/42/CE).

6 PERIODIC MAINTENANCE

Failure to adhere to the norms and established times for maintenance operations, will be detrimental to the good functioning of the equipment and will annul the guarantee conditions.

All maintenance operations must be carried out with the forklift motionless and the hydraulic circuit not activated, perimeter the entire maintenance area, using the necessary protective devices and, if it is necessary to disassemble the cylinders, always using a tray or container to recover the oil still present in the cylinder itself.

To avoid problems regarding the use of the equipment, A.T.I.B recommends changing the hydraulic oil and its filters regularly and trying to keep the system as clean as possible during maintenance operations.

WARNING!!!

The hydraulic parts can be very hot. Use adequate protections.

Beware of any leaks. Oil under high pressure can damage the eyes and skin. Always wear protective goggles on the sides as well.

Never remove valves, hoses or other potentially pressurized parts when it is active.

6.1 Maintenance Every 100 Hours

1. Check the conditions of the hydraulic connections (pipes and fittings), replacing, if necessary, the worn parts.
2. Check the tightening torque of the bolts of the lower sealing hooks of the equipment, verifying that it is as indicated in *Tab. 3 (pag. 14)* and *Tab. 4 (pag. 17)*, if necessary, intervene on the tightening of the screws that support them.
3. Check the clearance between the lower part of the fork holder plate and the lower hooks of the equipment, verifying that it is as indicated in *Picture 7 (pag. 14)* and *Picture 10 (pag. 17)*, if necessary, intervene on the tightening of the screws that support them.
4. Check the correct tightening of the locking screws of the fork stops. If necessary, intervene on the tightening.
5. Clean and lubricate all sliding parts (*Picture 26 and Picture 27a pag. 37*).

6.2 Maintenance Every 300 Hours

1. Check the condition of upper and lower sliding devices if an excessively worn component is found, it is recommended to replace the entire assembly of the component in question.
2. Also carry out the operations listed in the previous point (Point 6.1).

6.3 Maintenance Every 1000 Hours

1. Check the condition of upper and lower sliding devices if an excessively worn component is found, it is recommended to replace the entire assembly of the component in question.
2. Check the state of the sliding axis, making sure it is not scratched or deformed in any way.
3. Also carry out the operations listed in the previous points (Point 6.1 e 6.2 pag. 24).

6.4 Maintenance Every 2000 Hours

1. Proceed with a thorough inspection of the equipment; this, possibly, must be performed by qualified personnel, able to identify any problems that could compromise the safety and efficiency of use of the equipment. The defects that can be found can be many:
 - Check the condition of all equipment components (cylinders, hooks, gaskets, fittings, grease nipples, etc.), verifying that their conditions are optimal and, if there are worn components, proceed with their replacement / repair.
 - Check the condition of the sliding and working surfaces and proceed with their replacement / repair if they are damaged.

For further possible problems (and relative solutions) refer also to *Tab. 5 pag. 36*.

2. Disassemble the cylinders and check the condition of the rods and seals, if there is a damaged or excessively worn seal, it is always recommended to replace the entire assembly seals.
3. Replace the seals even in the event of oil leaks and the rods if scratched (the cylinders must always be tested inserted in the equipment in order to avoid the sudden expulsion of the rods).
4. Also carry out the operations listed in the previous points (*Point 6.1*, and *Points 6.2, 6.3* at pag. 24).

Please Note: Intensify interventions in case of use in particularly severe conditions.

7 DISASSEMBLY PROCEDURE

7.1 Disassembly attachments from forklift

1. Relieve the pressure of the hydraulic system.
2. Remove the forks, following the operations indicated in the *fork's installation* phase and *attachment installation* in reverse.
3. Unscrew the lower hooks of equipment (*Picture 4 and Picture 8 pag. 12, 15*).
4. For handling, use belts or chains appropriately sized for the weight of the equipment, indicated on the plate.
5. with an overhead crane or with a hoist of sufficient capacity hook the attachment and taking care to position the equipment correctly (*Picture 5 and Picture 9 pag. 12, 16*).

7.2 Forks disassembly

For handling, two belts or chains sized for the weight of the forks must be used, which will be wrapped around two points of the lower ends of the forks themselves, ensuring the stability of the fork.

1. Relieve hydraulic system pressure and disconnect hoses.
2. Remove all screws blocking the forks (vedi *Picture 16*).
3. Remove the forks, one at a time.

NOTE: The forks are the same for each type, and therefore also the disassembly method.

The arms of the external forks are made up by two parts, lower and upper, therefore, once the fork has been removed, pay attention to any dangerous movements / oscillations of the lower arm.

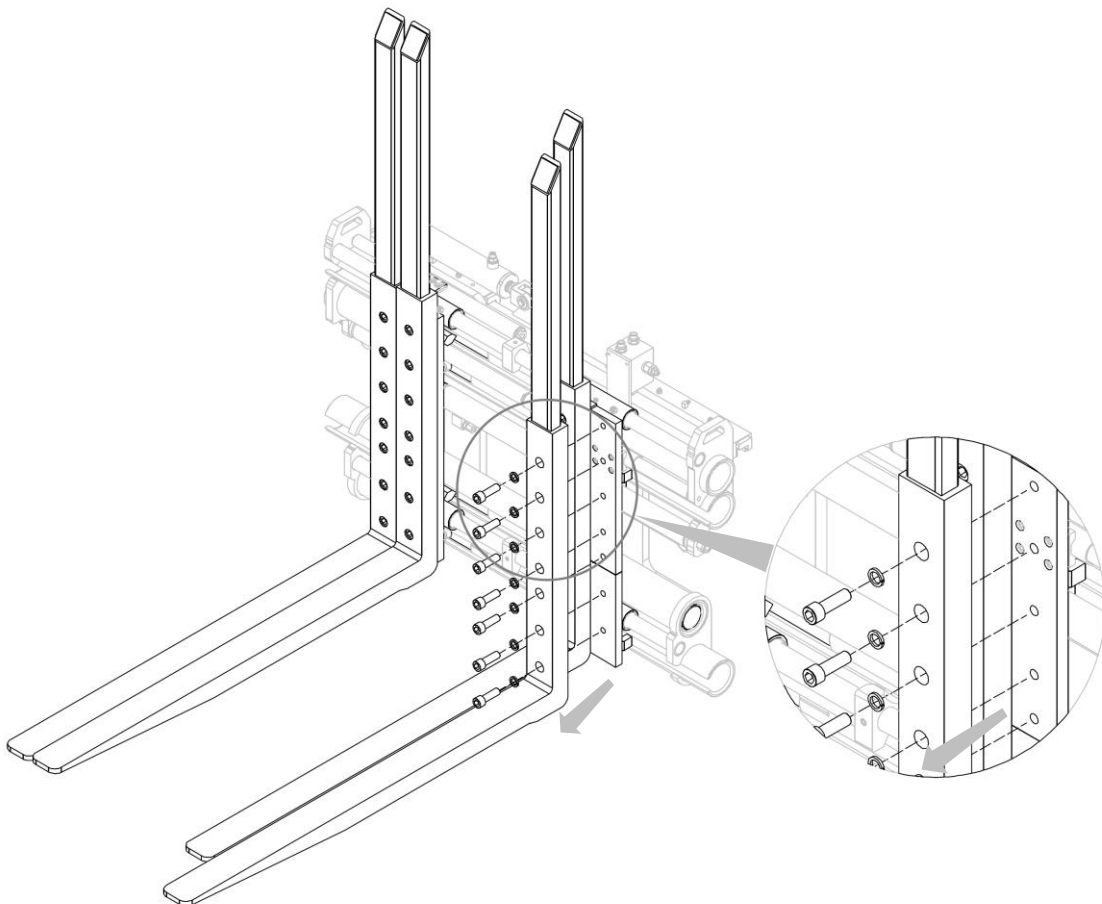

Picture 16

7.3 Fork cylinders removal from attachments

NOTE: the forks are the same for all type of attachments, therefore the disassembly procedure is the same.

1. Relieve the pressure of the hydraulic system and disconnect the pipes.
2. To facilitate removal, it is recommended that the cylinders be completely closed, in the image the equipment is shown with the cylinders open but only for better visibility.
3. Remove the cylinders from their seats, after having unscrewed the relative nuts D, taking care not to hit the other components of the equipment.
4. Refer to *Picture 17*.

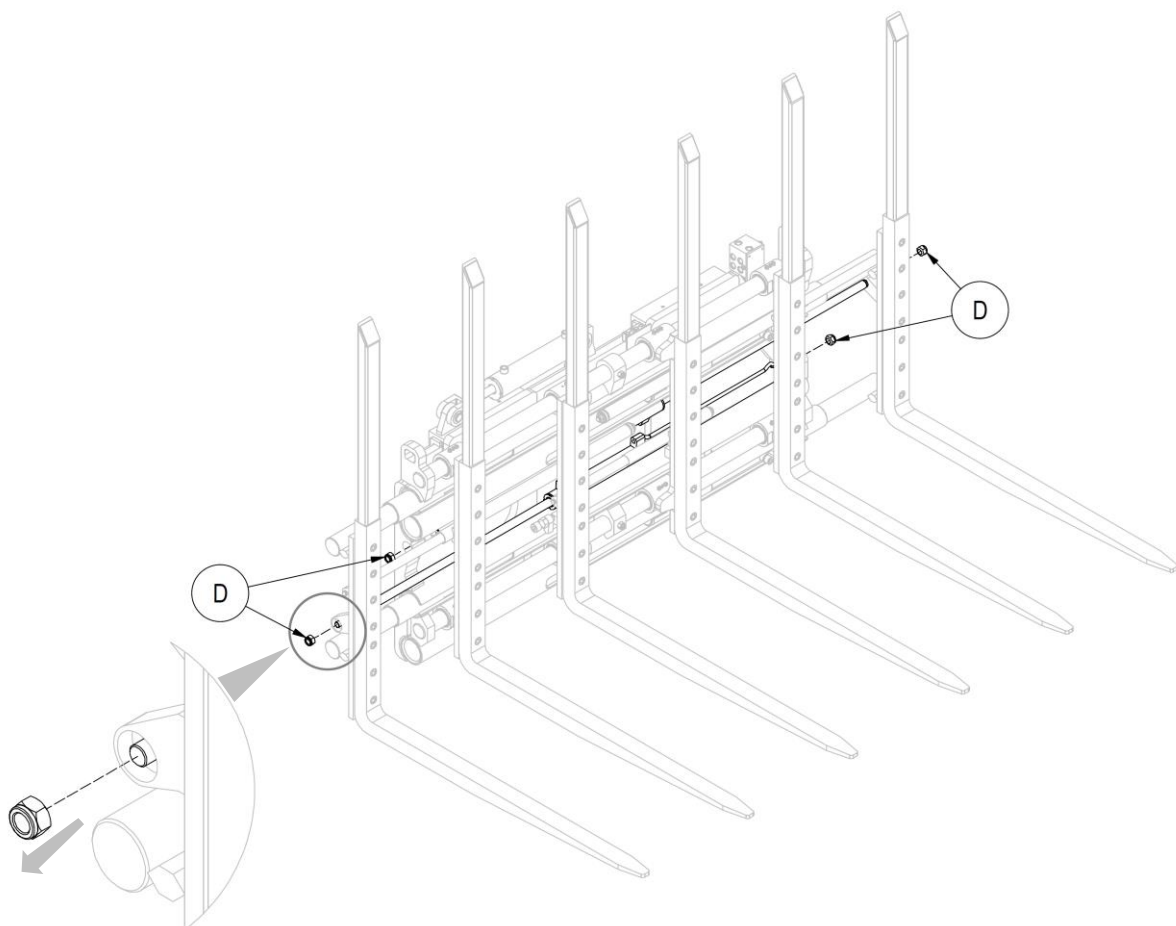

Picture 17

7.3.1 Disassembly and reassembly of the fork cylinders

If it is necessary to replace the entire cylinder, reassemble everything following the instructions listed in the previous point in reverse, if you also need to replace some cylinder component, proceed as indicated below:

1. Clamp the cylinder in a vice with soft jaws (taking care not to deform the cylinder housing).
2. Unscrew cap T with a sector wrench.
3. If you find it difficult to unscrew the cap, it is necessary to slightly heat the area of the thread concerned to facilitate unscrewing.
4. Unscrew the stem C.
5. Disassemble / separate the rest of the components and seal kit from each other (at this point it will be easy and intuitive)
6. Replacing the worn components, follow the previous steps in backwards, re-lock the cap applying a medium strength thread locker.
7. If there is a damaged seal, it is advisable to replace the entire kit.
8. Refer to *Picture 18*.

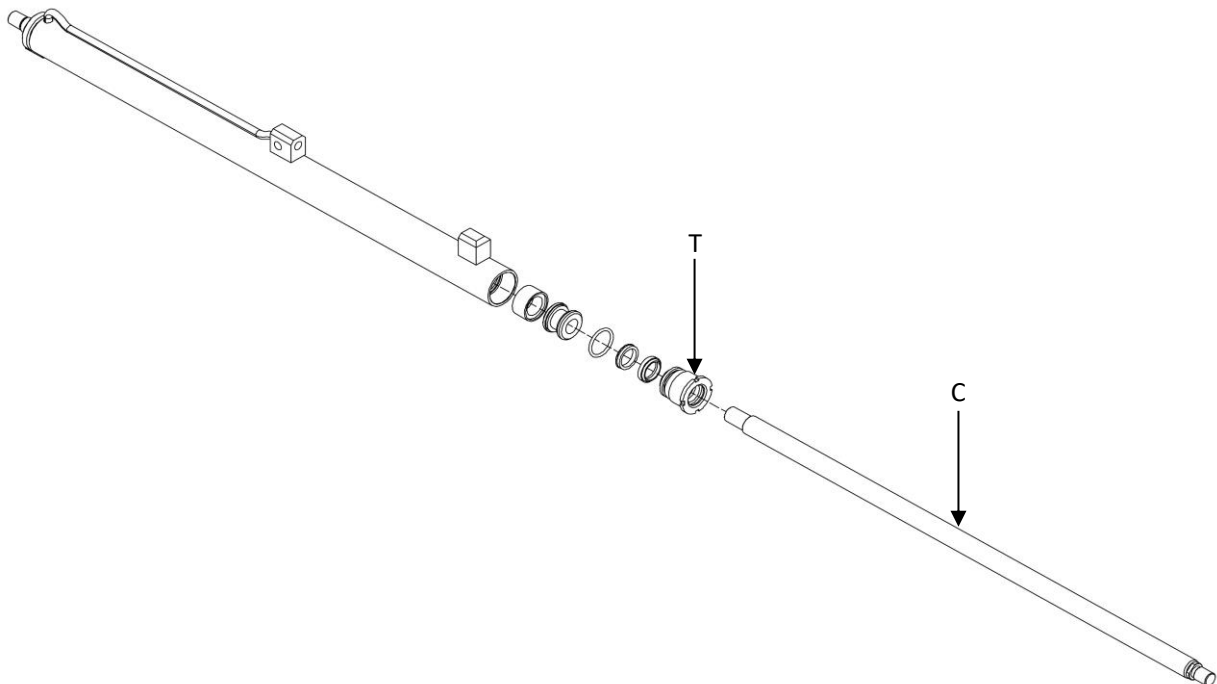

Picture 18

7.4 Gas spring removal from attachment

NOTE: The gas spring are the same for all type of attachments, therefore the disassembly procedure is the same.

1. Discharge the pressure of the hydraulic system and disconnect the pipes after having completely opened the fork cylinders.
2. To carry out the operation safely and avoid unpleasant inconveniences such as the sudden opening of the spring, it is necessary to carry out the operation with the spring itself already fully open.
3. Remove the fork concerned, after removing the relative screws (*Picture 19*).

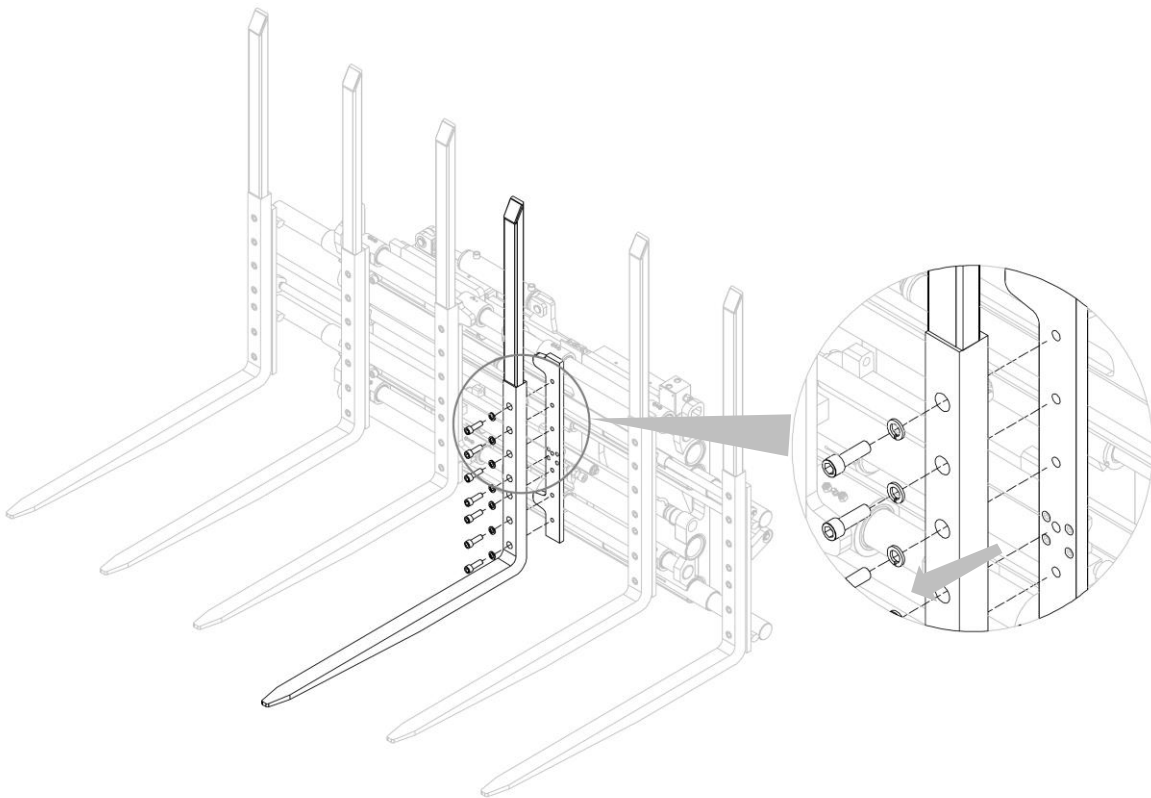

Picture 19

4. Remove the elastic ring that blocks one end of the spring (*Picture 20*).

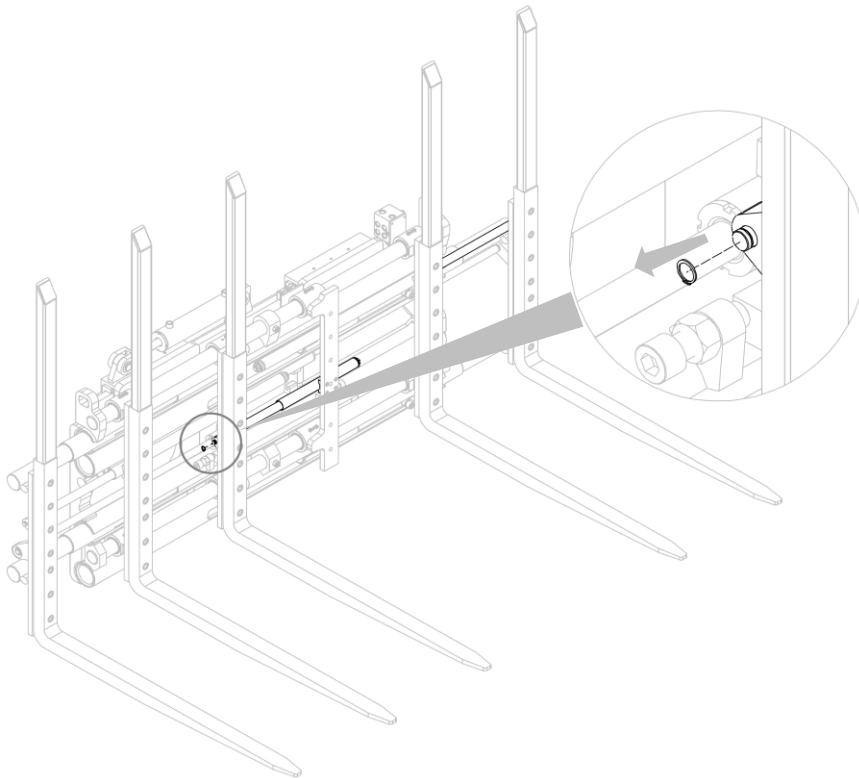

Picture 20

5. Remove the screws that bind the spring to the relative fork (more specifically to the fork-holder profile) and remove it from its seat, taking care not to hit the other components of the equipment (*Picture 21*).

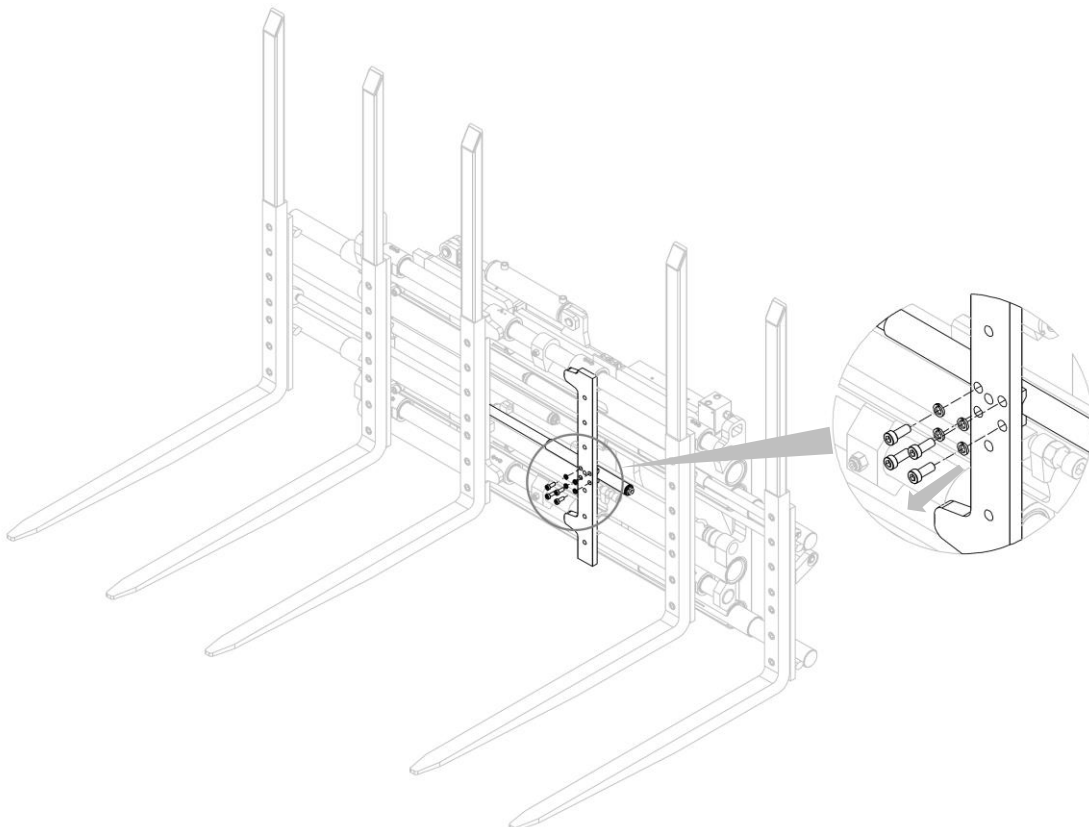

Picture 21

7.4.1 Disassembly and reassembly of the gas spring

If it is necessary to replace the entire gas spring, reassemble everything following the instructions listed in the previous point in reverse, if you also need to replace some component, proceed as indicated below:

1. Clamp the saucer in a vice (being careful to not deform it).
2. Unscrew the cap, it is screwed inside the spring body.
3. Unscrew the pins screwed to the ends of the spring.
4. Separate the components from each other and replace the necessary parts.
5. Reassemble everything following the steps listed above in reverse.
6. Refer to *Picture 22*.

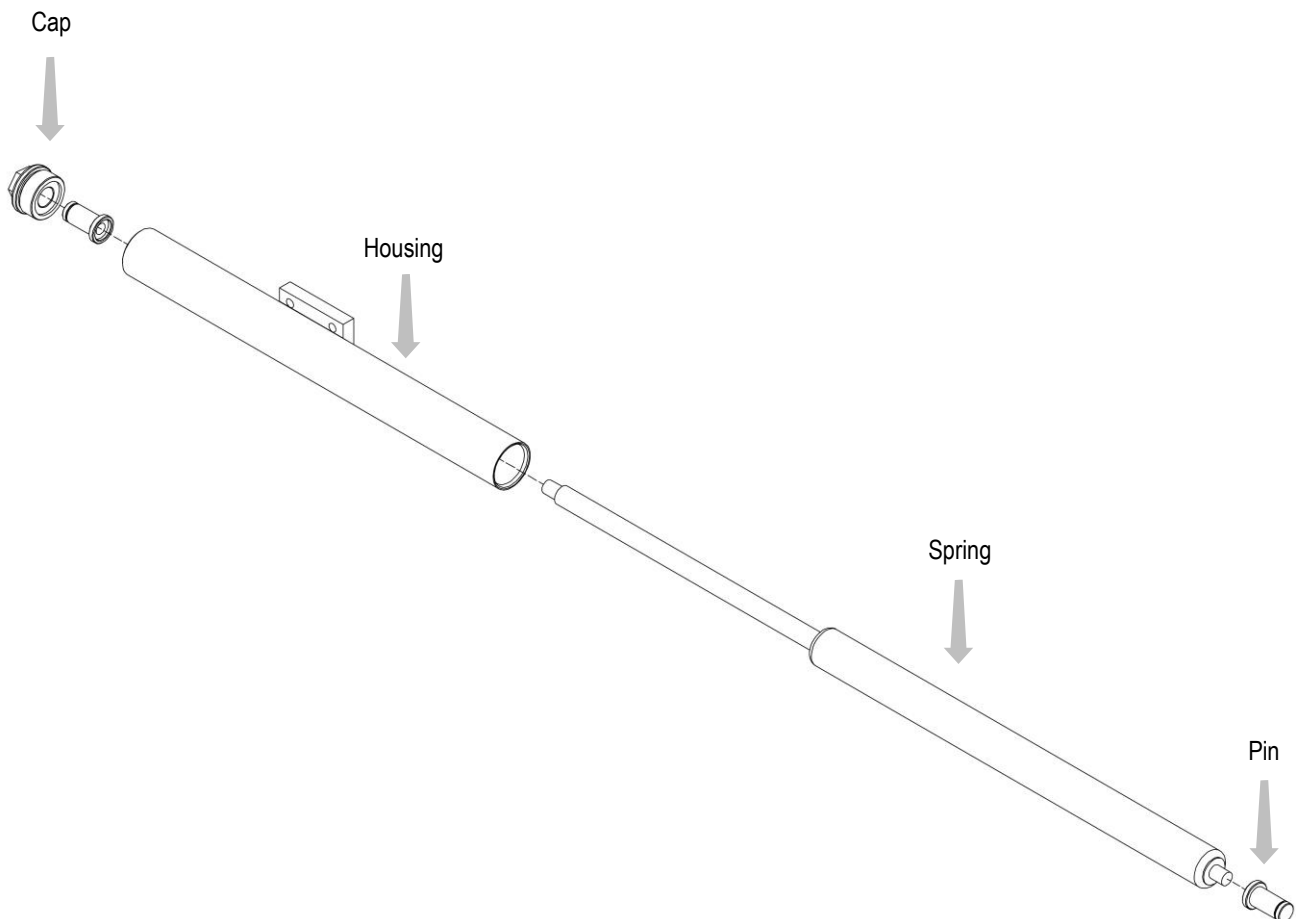

Picture 22

7.5 SLS cylinder removal from attachment

NOTE: The SLS cylinders are the same for all type of attachments, therefore the disassembly procedure is the same.

1. Relieve the pressure of the hydraulic system.
2. Remove the two pins, with the relative elastic rings, which block the SLS cylinder.
3. Remove the cylinder.
4. Remove the stems and relative seal kit from their seat, one at a time.
5. Replace the worn parts, and reassemble everything, following the steps listed above in reverse.
6. 7. If there is a damaged seal, it is advisable to replace the entire kit.
7. Refer to *Picture 23*.

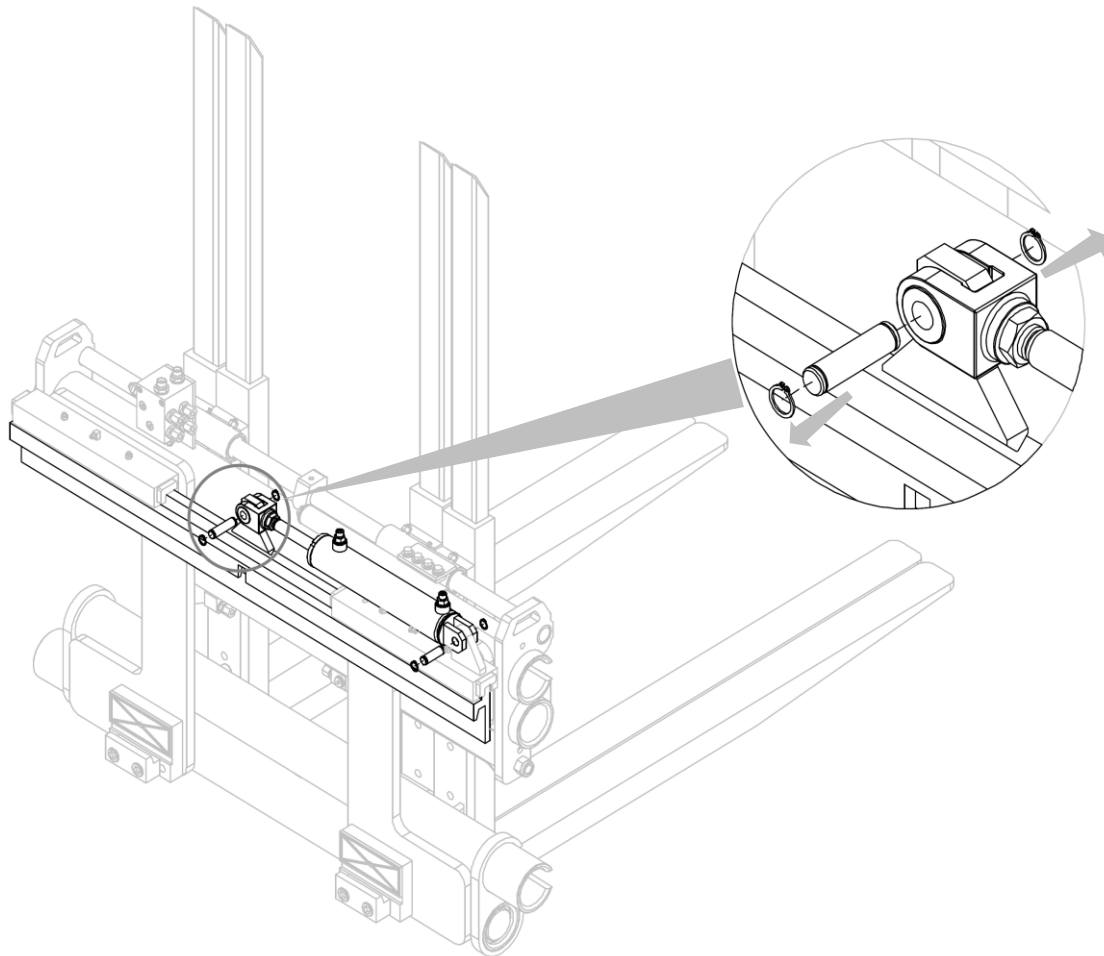

Picture 23

7.5.1 Disassembly and reassembly SLS cylinder

If it is necessary to replace the entire SLS cylinder (use new one), reassemble everything following the instructions listed in the previous point in reverse, if you also need to replace some component, proceed as indicated below (*Picture 24*):

1. Place the cylinder on a horizontal plane.
2. Loosen the lock nut that locks the fork.
3. Unscrew the fork.
4. Unscrew the cylinder head.
5. Remove the cap.
6. The threads of ATIB cylinders are usually blocked with the aid of a thread locking solution. If you find it difficult to unscrew the cap, it is necessary to slightly heat the area of the thread concerned to facilitate unscrewing.
7. Separate the components from each other and replace the necessary parts.
8. If there is a damaged seal, it is advisable to replace the entire kit.
9. Reassemble everything, following the steps listed above in reverse.

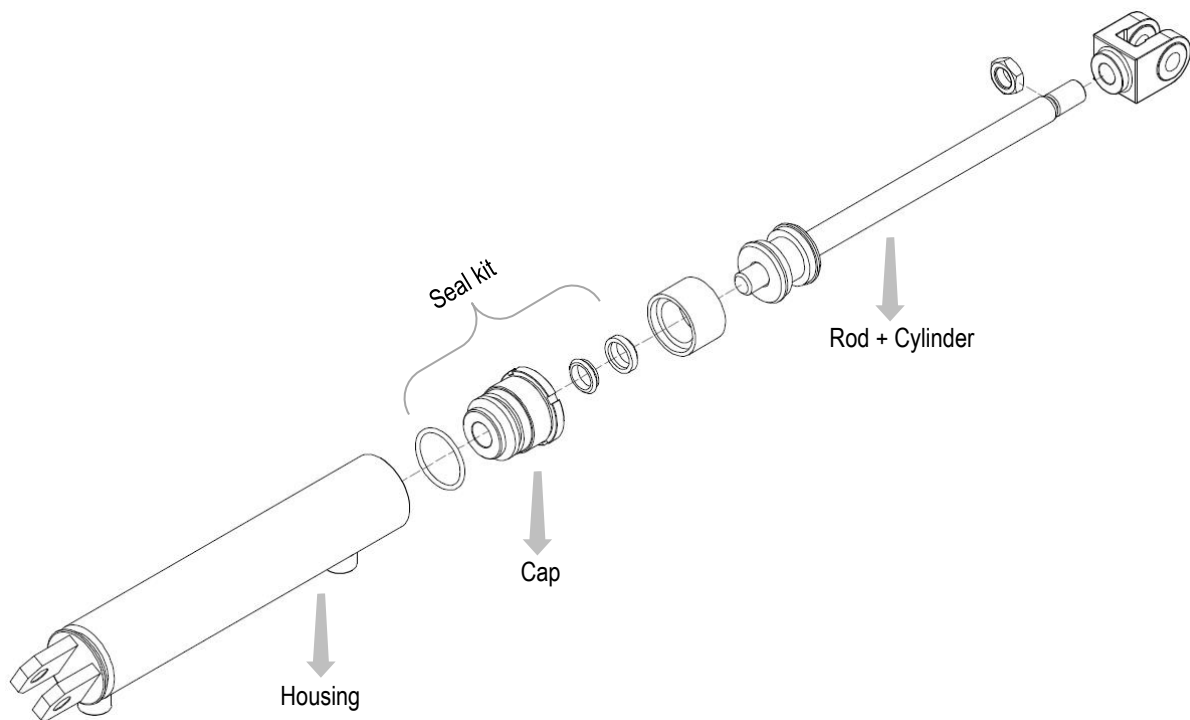

Picture 24

7.5.2 SLS Sideshift Bushing Maintenance

NOTE: The sliding bushings are the same for each SLS type, and therefore also the disassembly method.

1. Remove the pressure from the hydraulic system and disconnect the pipes.
2. Remove the sideshift cylinder.
3. Remove the equipment from the truck.
4. Remove the bushings after removing the relative screws that lock them (see Figure 25).
5. If damaged and / or excessively worn, replace the screws and reassemble the new ones by following the above instructions backwards.

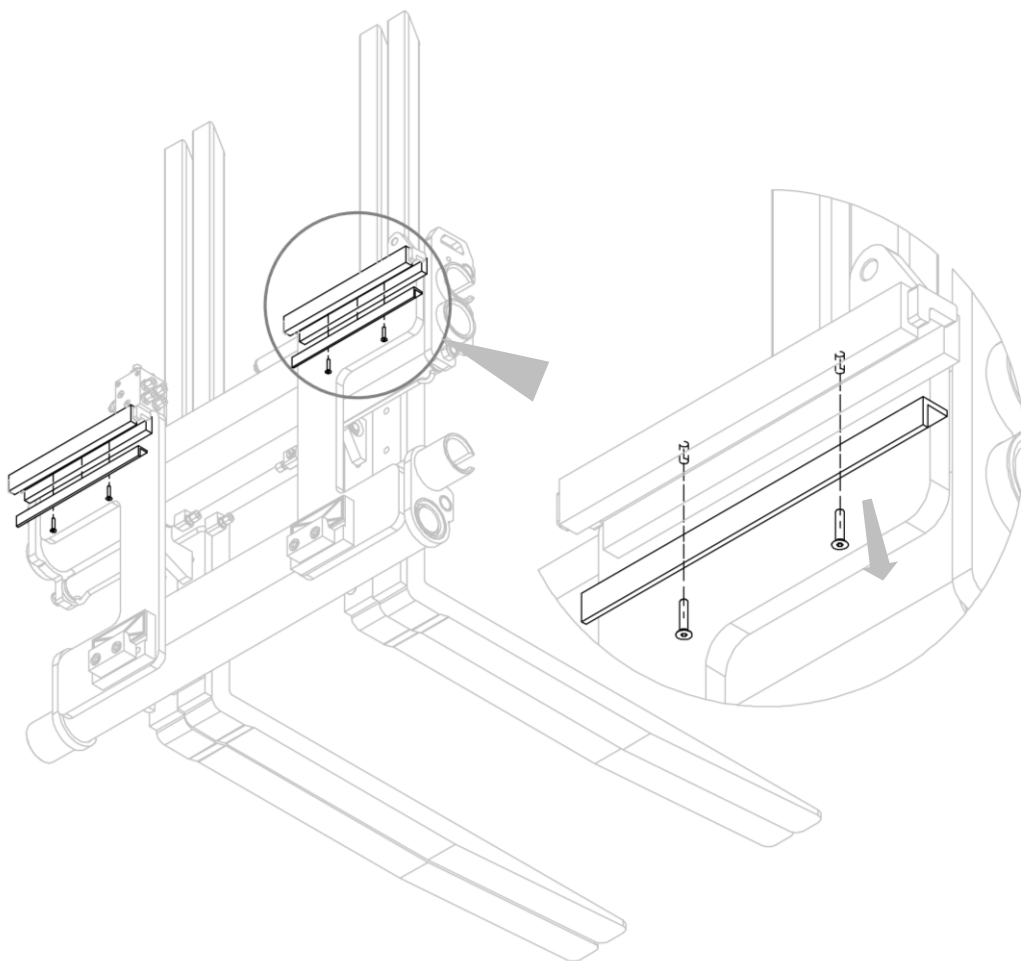

Picture 25

8 BREAKDOWNS AND SOLUTIONS

8.1 Breakdowns and solution

FAILURE	CAUSE	SOLUTION
Insufficient strength	Too low setting of the maximum pressure valve	Increase the pressure without exceeding the maximum limit
	Insufficient pressure	Contact the forklift manufacturer
	Worn Pump	Replace
	worn cylinder seals	Replace
	Lack of oil in the tank	Top up
Loss of pressure	leakage of oil from the pipes and joints	Tighten the joints or replace them
	leakage of oil from the cylinders	Replace seal kits or, if it is necessary, the cylinders
	Loss load while sideshifting	Lower the side shift pressure
	Loss load	Verify the blades cambering's
Slow opening and closing	Low oil flow	Check the tank level and the pump
		Bottlenecks in the system: search and delete them
	Insufficient pressure	Set the maximum pressure valve
	Mechanical deformations of some parts	Repair or replace
	Worn cylinder seals	Replace
Irregular side shift	Lack of oil in the tank	Top up
	Presence of air in the hydraulic system	Bleed the hydraulic system
	Sliding parts usurated	Replace
	Excessive friction between the sliding parts	Clean and lubricate the sliding parts
	Worn cylinder seals	Replace
Lack of oil in the tank	Top up	

Tab. 5

Should there be other problems, please contact A.T.I.B. S.r.l.

8.2 Lubrication

1. Lubricate the sliding parts using the special grease nipples.
2. Lubricate the slide and relative scroll bar using the special grease nipples.
3. Lubricate the double hook using the special grease nipples (only for version with SLS).

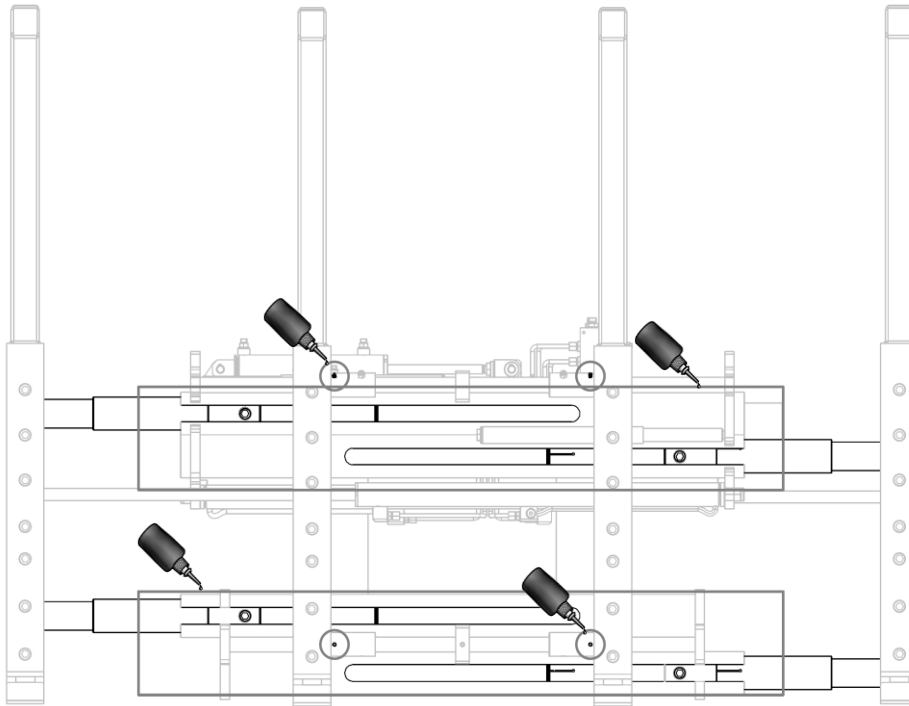

Picture 26

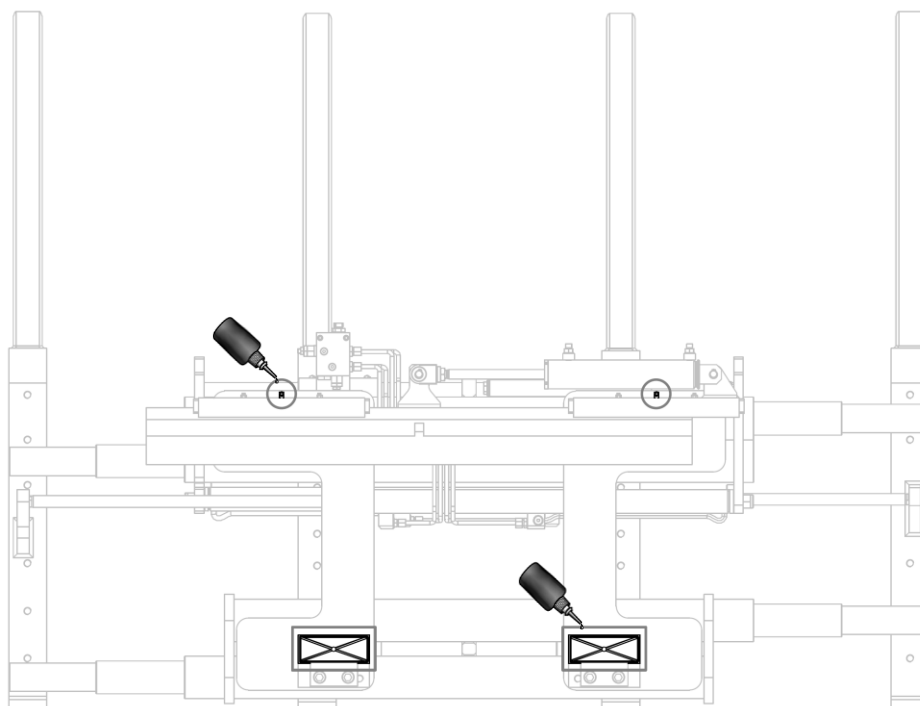

Picture 27

A.T.I.B. S.r.l.

Via Quinzanese snc, 25020 Dello (BS) - ITALY

+39 030 977 17 11

info@atib.com

atib.com

