



ATI3 MATERIAL
HANDLING

USE AND MAINTENANCE MANUAL

BOX TIPPER ROTATING 360° TYPE 213

TABLE OF CONTENTS

BOX TIPPER ROTATING 360° TYPE 213



READ THIS USE AND MAINTENANCE MANUAL CAREFULLY BEFORE
COMMISSIONING THE MACHINE

1	SAFETY REGULATIONS FOR THE OPERATOR.....	3
2	INTRODUCTION	4
2.1	Use and Storage of the Manual	4
2.2	Equipment Description	5
3	INSTALLATION	9
3.1	Installation Procedure	10
3.1.1	Installing the Equipment	10
3.1.2	Installing the Equipment - With Siss	14
3.2	Installing the Forks onto the Equipment.....	18
4	HYDRAULIC SYSTEM.....	19
4.1	Hydraulic system - Standard.....	19
4.2	Hydraulic System - with SISS.....	20
	20
5	RULES GOVERNING USE	21
5.1	Handling Loads	22
6	PERIODIC MAINTENANCE.....	23
6.1	Maintenance Every 100 Hours	23
6.2	Maintenance Every 300 Hours	23
6.3	Maintenance Every 1000 Hours	24
6.4	Maintenance Every 2000 Hours	24
6.5	Rotation Device Maintenance	25
6.5.1	Maintenance Every 200 Hours	25
6.5.2	Maintenance Every 2000 Hours	25
7	DISASSEMBLY PROCEDURE	26
7.1	Removing the Equipment from the Forklift Truck.....	26
7.2	Disassembling the Swing Arm.....	27

7.2.1	Removing the Plate-Holder Arm.....	27
7.2.2	Removing the Skip Retaining Plate.....	28
7.3	Removing the Forks from the Equipment.....	29
7.4	Removing the Plate Articulation Cylinder.....	30
7.4.1	Disassembling and Reassembling the Cylinder.....	31
7.5	Removing the Sideshift Cylinder - SISS TYPE.....	32
7.5.1	Disassembling and Reassembling the Cylinder.....	33
7.6	Disassembling the Gearbox and Motor.....	34
7.7	Disassembling the Slewing Ring.....	35
8	TROUBLESHOOTING.....	36
8.1	Probable Faults and Solutions.....	36
8.2	Lubrication.....	37

1 SAFETY REGULATIONS FOR THE OPERATOR



Do not transport passengers



Do not cross the upright



Do not stand under the load

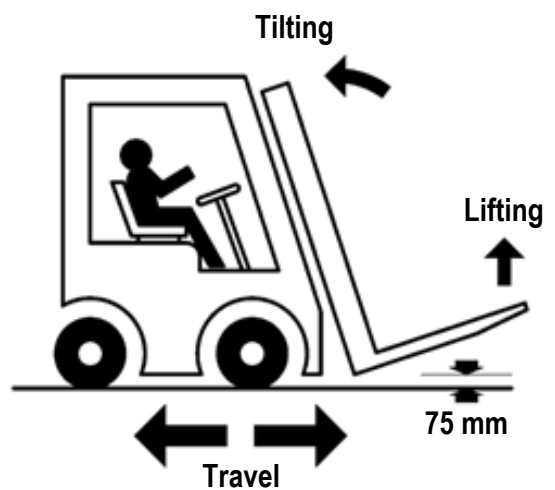

2 INTRODUCTION

2.1 Use and Storage of the Manual

This "Use and Instruction Manual" (hereinafter referred to as the Manual) is issued together with the A.T.I.B. equipment. – "BOX TIPPER ROTATING 360° TYPE 213" in accordance with DIRECTIVE 2006/42/EC OF THE EUROPEAN PARLIAMENT AND OF THE COUNCIL of 17/05/2006 and subsequent additions.

The following indications are essential for correct use of the equipment and must be brought to the attention of the personnel assigned to installation, use, maintenance and repair.

This Manual must be considered an integral part of the equipment and must be kept until it is dismantled in an accessible, protected and dry place and must be available for quick reference.

In the event of loss and/or damage, the user can request a copy from the manufacturer.

The manufacturer reserves the right to modify this manual without prior notice and without the obligation to update previously distributed copies.

The manufacturer is exempted from any responsibility in the event of:

- Improper use of equipment;
- Use of equipment by untrained personnel;
- Use contrary to any national or international regulations;
- Inadequate scheduled maintenance;
- Unauthorised intervention or modification;
- Use of non-original and/or non-model specific spare parts;
- Full or partial non-compliance with instructions;
- Exceptional events.

**The nominal capacity of the forklift truck/equipment combination has been set by the original manufacturer of the forklift truck and may be less than that indicated on the equipment plate.
Consult forklift truck plate (Directive 2006/42/EC).**

2.2 Equipment Description

TYPE 213

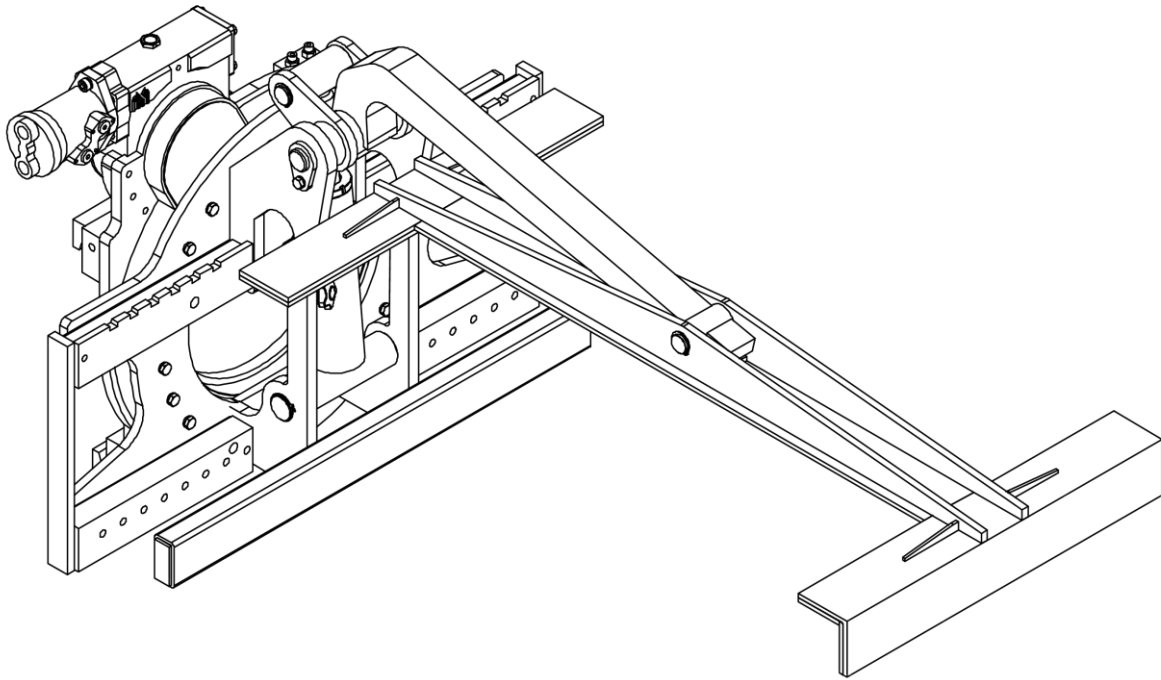

TYPE 213 WITH SISS

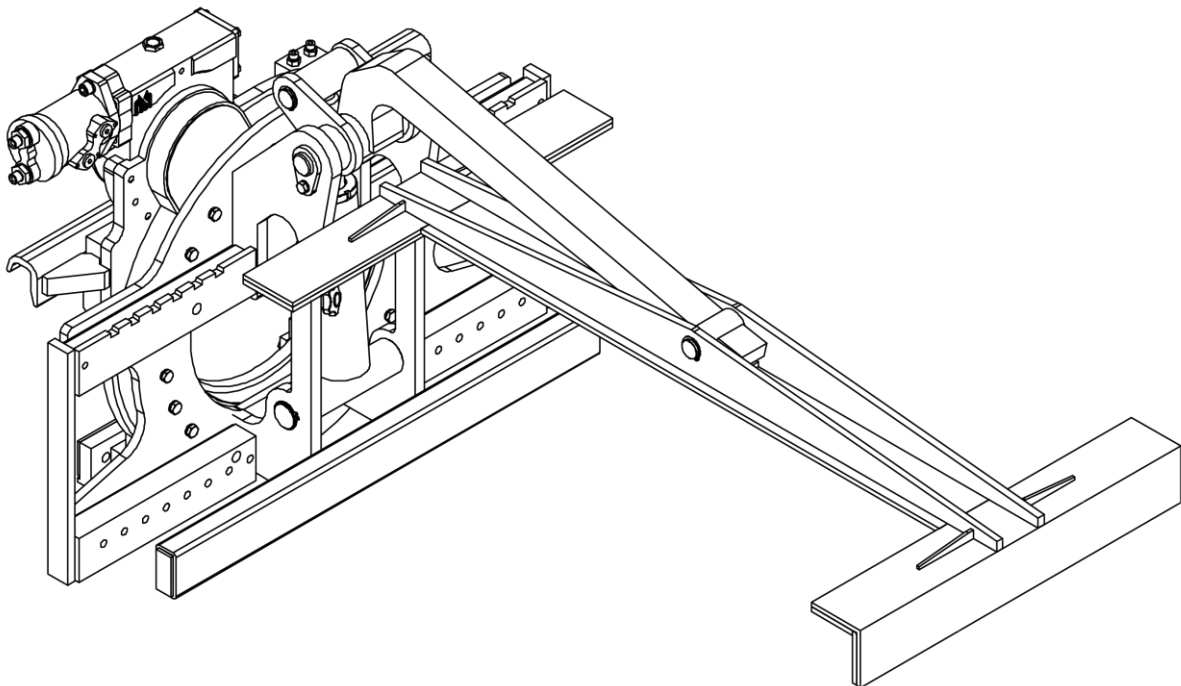

All the A.T.I.B. equipment - “BOX TIPPER ROTATING 360° TYPE 213” are identified by means of an adhesive plate (see *Table 1*) located on the equipment (see *Figure 1*, where the two most common locations of the rating plate are shown). Always refer to the serial number.

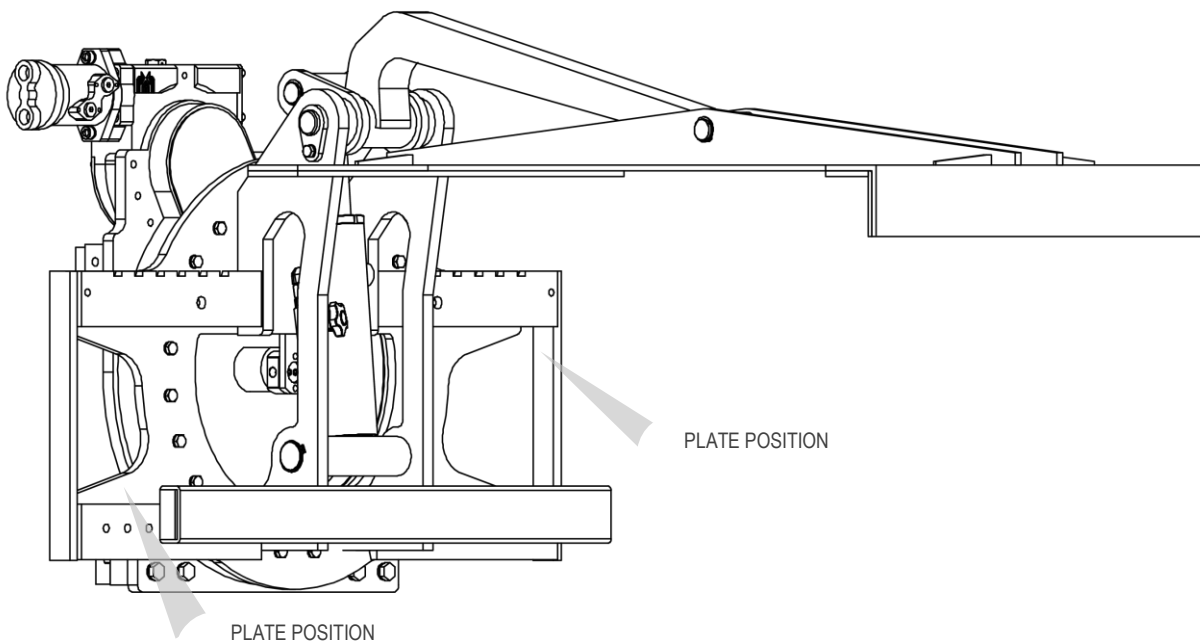

Figure 1



1. TIPO / TYPE	8. PORTATA NOMINALE / NOMINAL CAPACITY	kg/mm	11. COPPIA MAX / MAX. TORQUE	daNm
2. CODICE / CODE	9. PORTATA IN SERRAGGIO / CLAMPING CAPACITY	kg/mm	 	A.T.I.B. S.r.l. Via Quinzanese snc, 25020 Dello (BS) - ITALY +39 030 9771711 info@atib.com - atib.com
3. MATRICOLA N° / SERIAL N°				
4. ANNO DI COSTRUZIONE / YEAR OF MANUFACTURE	10. PRESSIONE MAX. DI ESERCIZIO / MAX. OPERATING PRESSURE	bar		
5. PESO / WEIGHT	NOTE: OSSERVARE I LIMITI DI PORTATA DELL'INSIEME CARRELLO CON ATTREZZATURA / WARNING: OBSERVE THE NOMINAL CAPACITY OF TRUCK AND ATTACHMENT COMBINED			
6. SPESSORE / THICKNESS				
7. CENTRO DI GRAVITÀ / CENTER OF GRAVITY				

Table 1

1. TYPE

Indicates equipment model as shown in the catalogue.

2. CODE

Indicates the equipment ordering code.

3. SERIAL N°

It progressively identifies the individual equipment.

In the event that the plate is missing or is damaged, the serial number is also stamped on the profile for connection to the fork-holder plate; for any information always refer to the serial number.

4. YEAR OF MANUFACTURE

Indicates the year of manufacture.

5. WEIGHT

Indicates the weight of the equipment in kg.

6. THICKNESS

Indicates the thickness of the equipment in mm.

7. CENTRE OF GRAVITY

Indicates the distance in mm of the *CG* centre of gravity of the equipment from the support plane of the fork-holder plate.

8. NOMINAL CAPACITY

Indicates the maximum load applicable to the lifting equipment and the maximum centre of gravity of the load itself.

9. CLAMPING CAPACITY

Not applicable to this equipment.

10. MAX. OPERATING PRESSURE

Indicates the maximum pressure expressed in bar at which the equipment can work.

11. MAX. TORQUE

Indicates the rotational torque of the equipment.

The A.T.I.B. equipment – “BOX TIPPER ROTATING 360° TYPE 213” has been conceived, designed and manufactured to lift, transport and empty skips for all types of use (scrap, recycling, agriculture, etc.).

This equipment must be attached to the forklift truck carriage and connected to the distributor via a hydraulic circuit.

The equipment is able to perform the following functions:

- Rotation: relative rotation between the parts attached to the fork carriage and those attached to the lifting equipment is achieved by means of a hydraulic motor integrated into the gearbox;
- Skip locking: movement relative to the skip retaining plate is achieved by using a hydraulic cylinder/pair of hydraulic cylinders;

Optional additional functions:

- SISS (SEMI-INTEGRAL SIDESHIFT): semi-integral sideshift motion between the parts attached to the fork carriage and those attached to the lifting equipment is carried out by means of a hydraulic cylinder;

Fork carriage coupling components are manufactured in accordance with ISO 2328.

3 INSTALLATION

Checking the Nominal Capacity of the Equipment

To check the nominal capacity of the clamp, refer to the clamp's rating plate (See *Table 1* on page 6).



Ensure that the driver of the forklift truck is aware of the maximum capacity of the equipment so that they do NOT constitute a hazard to themselves or to persons working in proximity.

The forklift truck manufacturer is responsible for calculating the residual load capacity of the truck/equipment combination.

Checking the Operating Pressure and Oil Flow Rate

A.T.I.B. recommends observing the hydraulic flow rates and operating pressures provided in *Table 2*, to optimise operation of the equipment and avoid issues during work or commissioning. Values are for indicative purposes only and may vary depending on the equipment.

TYPE and ISO	FLOW RATE (l/min)			Operating pressure Maximum (Bar)
	minimum	maximum	recommended	
213 (II)	10/ 10	60/ 40	25/ 25	175

Table 2

Values in bold refer to flow rates of functions other than those that are rotating.



OBSERVE THE INDICATED MAXIMUM OPERATING PRESSURES

3.1 Installation Procedure

3.1.1 Installing the Equipment

1. Prior to installation, check the condition of the fork carriage, ensuring that the lower profile is smooth.
2. Also make sure that the profiles of the fork-holder plate are not deformed, in order to ensure good coupling with the equipment.
3. Check the condition of the pipes, replacing those in a poor condition.
4. Remove the lower couplings from the equipment (see *Figure 2*).

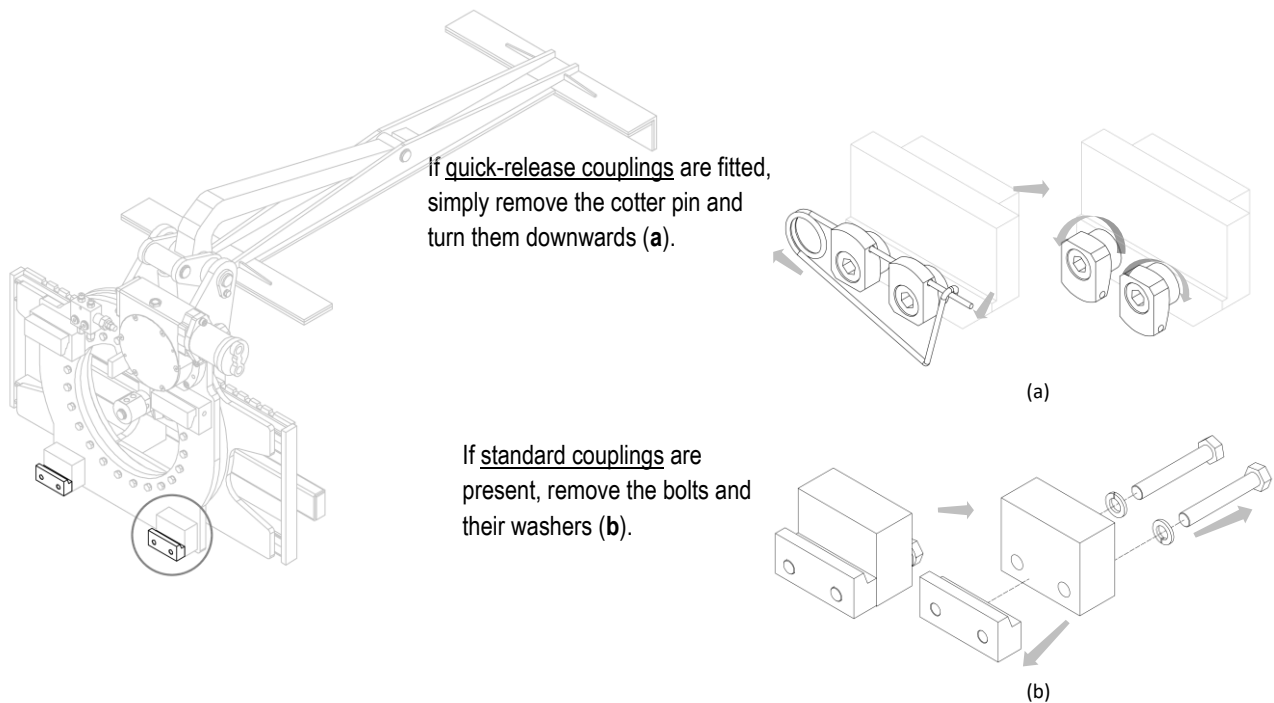

Figure 2

- For handling, use straps or chains suitably sized in relation to the weight of the equipment as indicated on the plate (see *Figure 1* and *Table 1* on page 6).

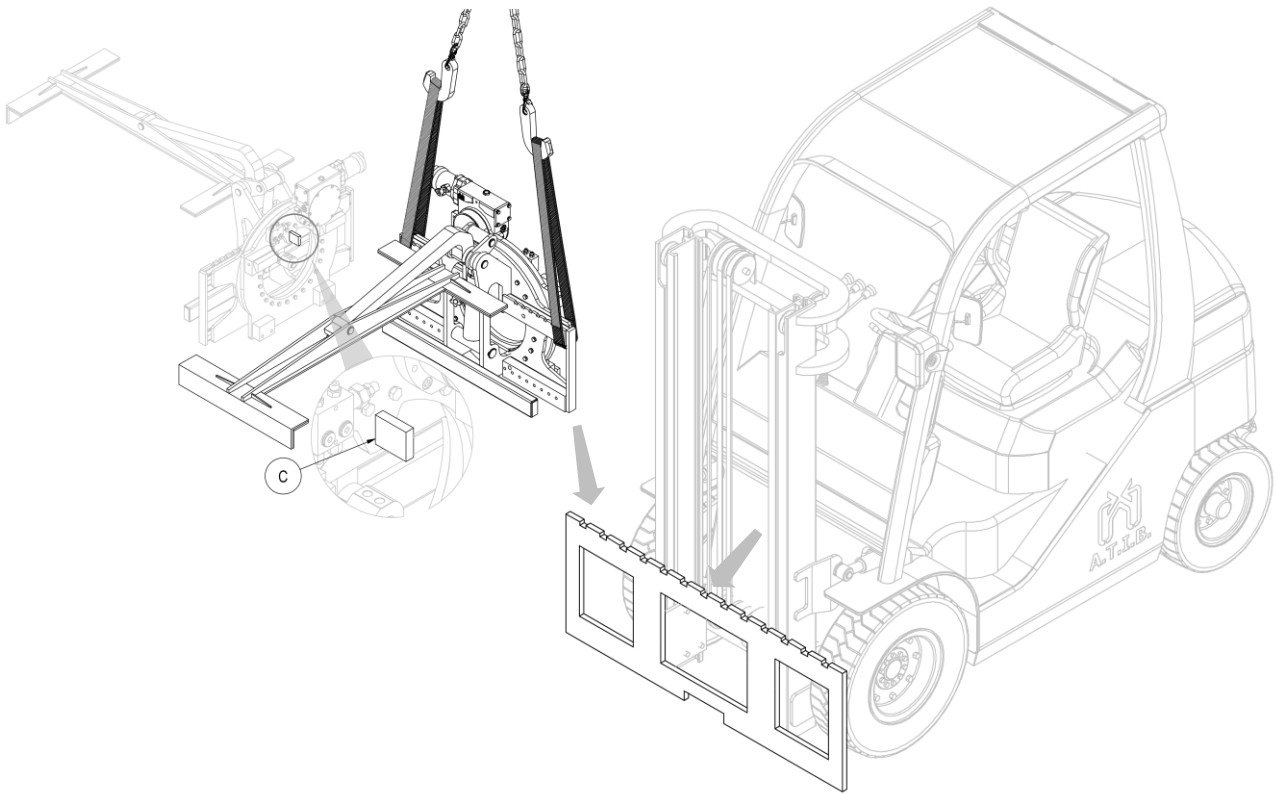

Figure 3

- Using an overhead crane or hoist of sufficient capacity, place the equipment on the fork carriage, taking care to engage the centring pin **C** in its central notch (see *Figure 3*).

7. Screw on the 2 lower couplings **G** in such a way that their bodies also remains coupled to the lower part of the fork carriage **P** (with max. clearance of 1.5 mm, see detail *Figure 4*), tightening with the torque indicated in *Table 3*.

CLASS	THREAD	TIGHTENING TORQUE
ISO II	M12	90 Nm

Table 3

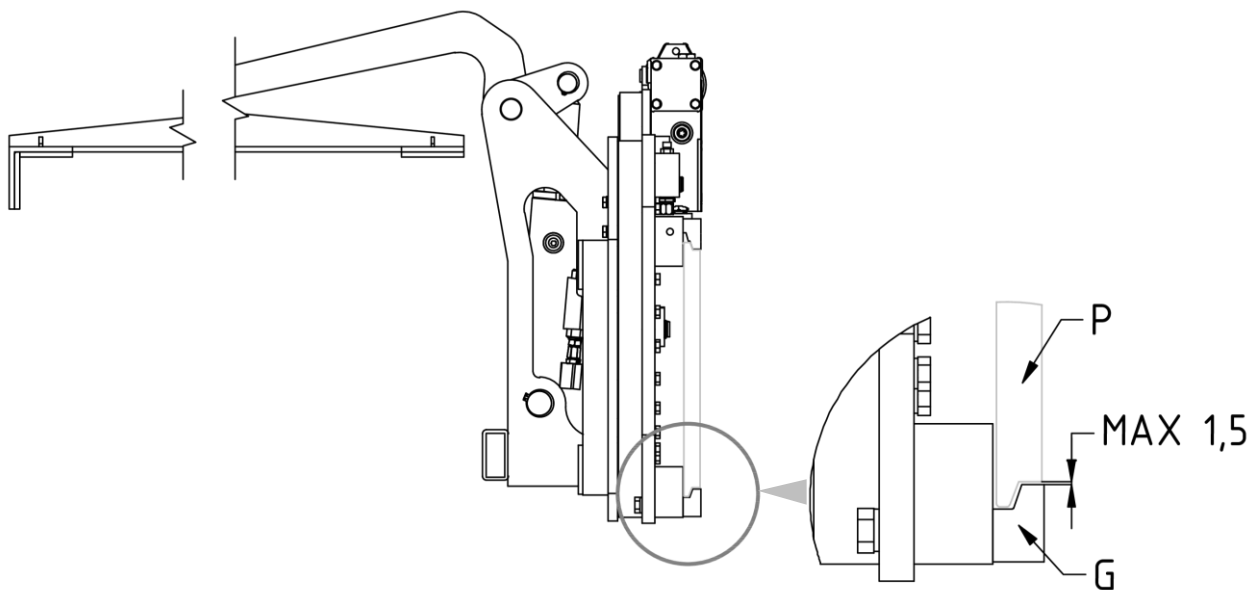

Figure 4

8. Mount the forks (see chapter *Installing the Forks* onto the Equipment on page 18).
9. Lubricate the contact surfaces (see chapter *Lubrication* on page 37).

10. **N.B.** With the equipment mounted, before use, replace the blind iron oil filler plug (F) with the plastic one supplied (P), which includes a breather (see *Figure 5*).

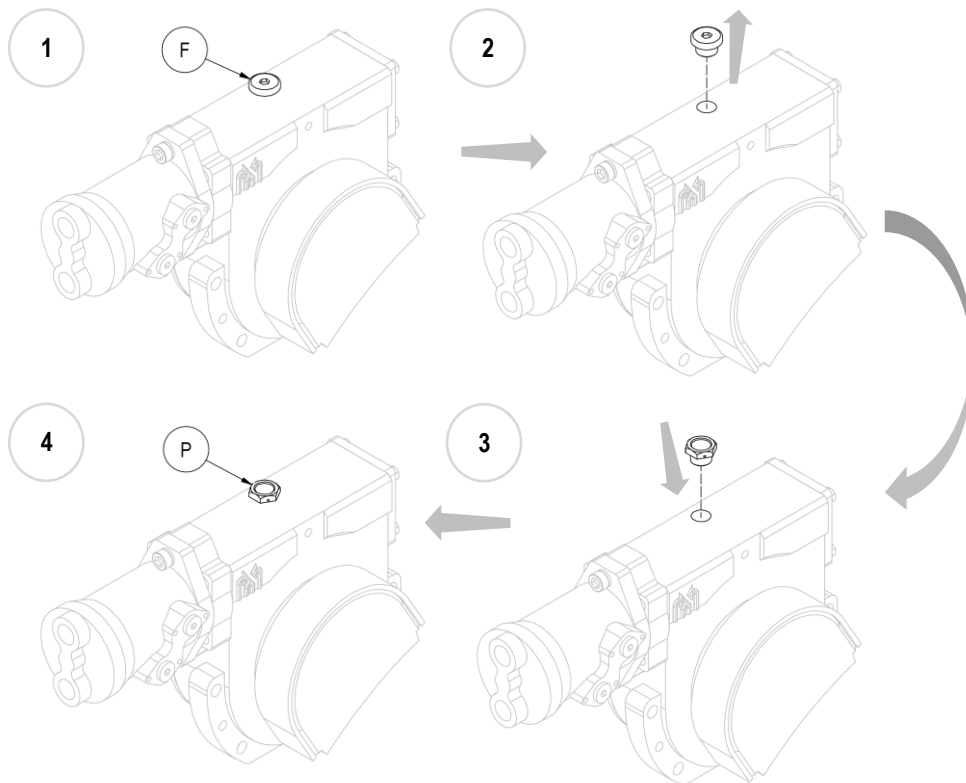

Figure 5

11. Connect the hydraulic circuit, ensuring that the operating pressure of the lines is greater than or equal to that indicated on the rating plate (see *Figure 1* and *Table 1* on page 6).

3.1.2 Installing the Equipment - With Siss

WITH SISS

1. Prior to installation, check the condition of the fork carriage, ensuring that the lower profile is smooth which may otherwise affect the sliding of the lower pads.
2. In addition, ensure that the fork carriage profiles are not deformed in order to facilitate good coupling with the sideshift equipment.
3. Check the condition of the pipes, replacing those in a poor condition.
4. Manually obtain the dual coupling **A** (with its sliding bushes and sideshift cylinder), and position it on the upper profile of the fork carriage, taking care to fit the centring pin **C** into its central notch (see *Figure 6*).

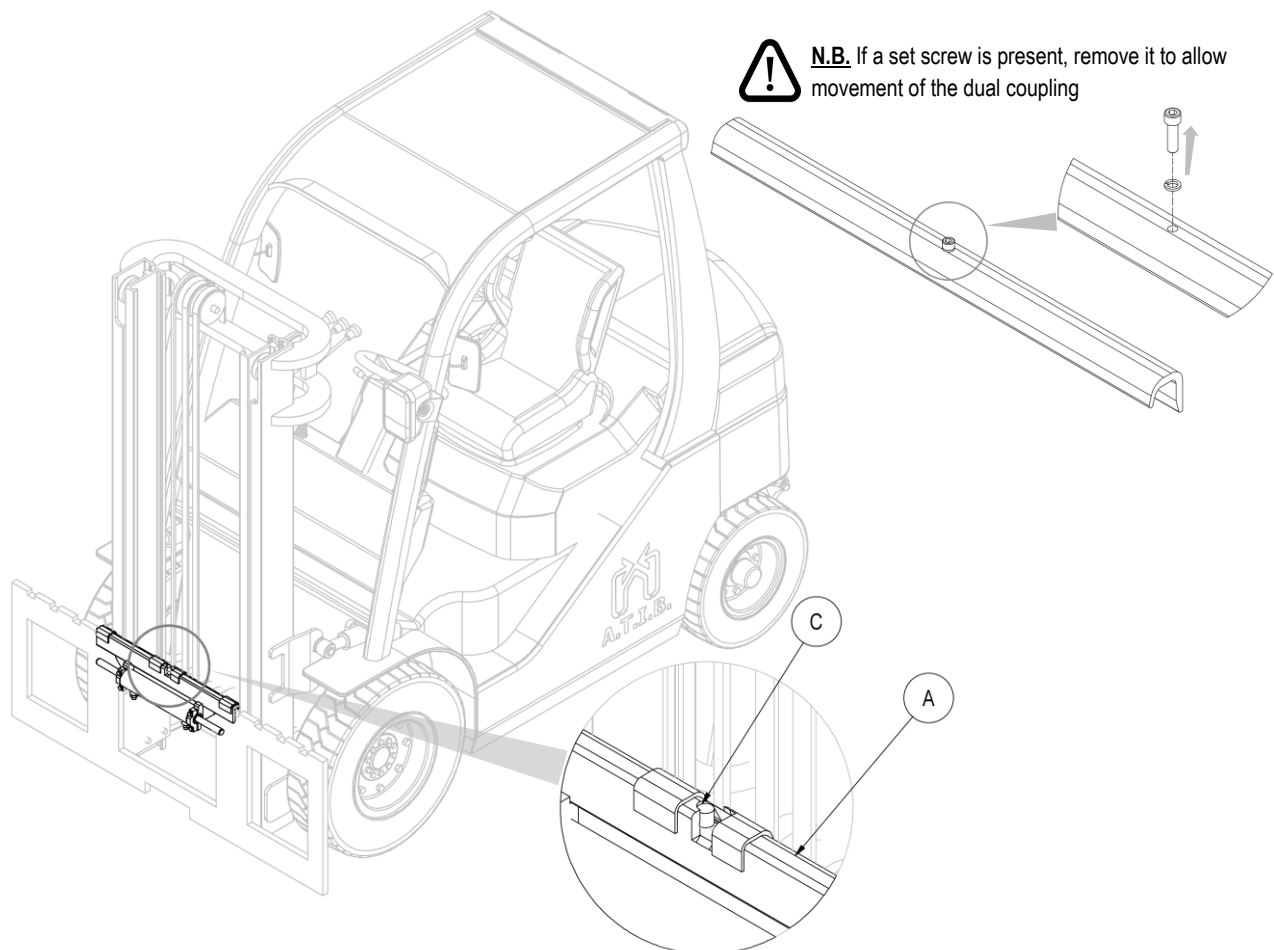

Figure 6

5. Remove the lower couplings from the equipment and grease the sliding gibs (see *Figure 7* ↗).

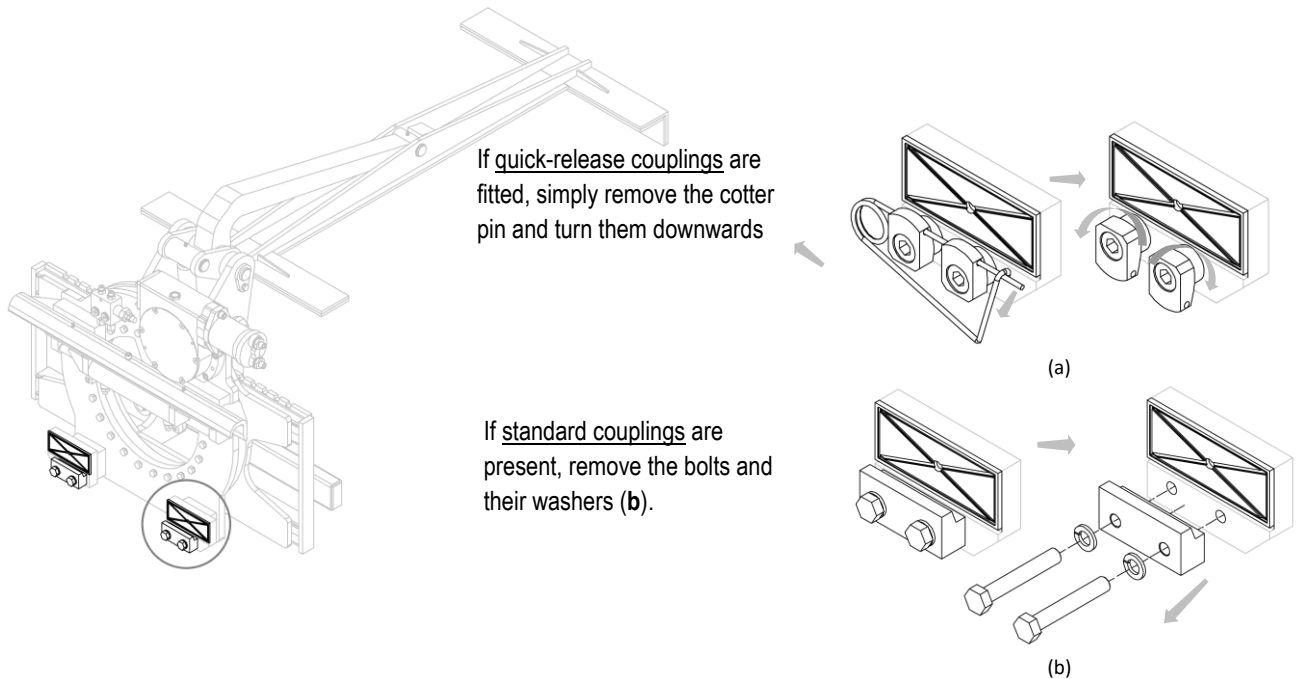

Figure 7

6. For handling, use straps or chains that are suitably sized in relation to the weight of the equipment as indicated on the plate (see *Figure 1* and *Table 1* on page 6).
7. Using an overhead crane or hoist of sufficient capacity, place the equipment on the dual coupling, taking care to position it correctly (see *Figure 8*).

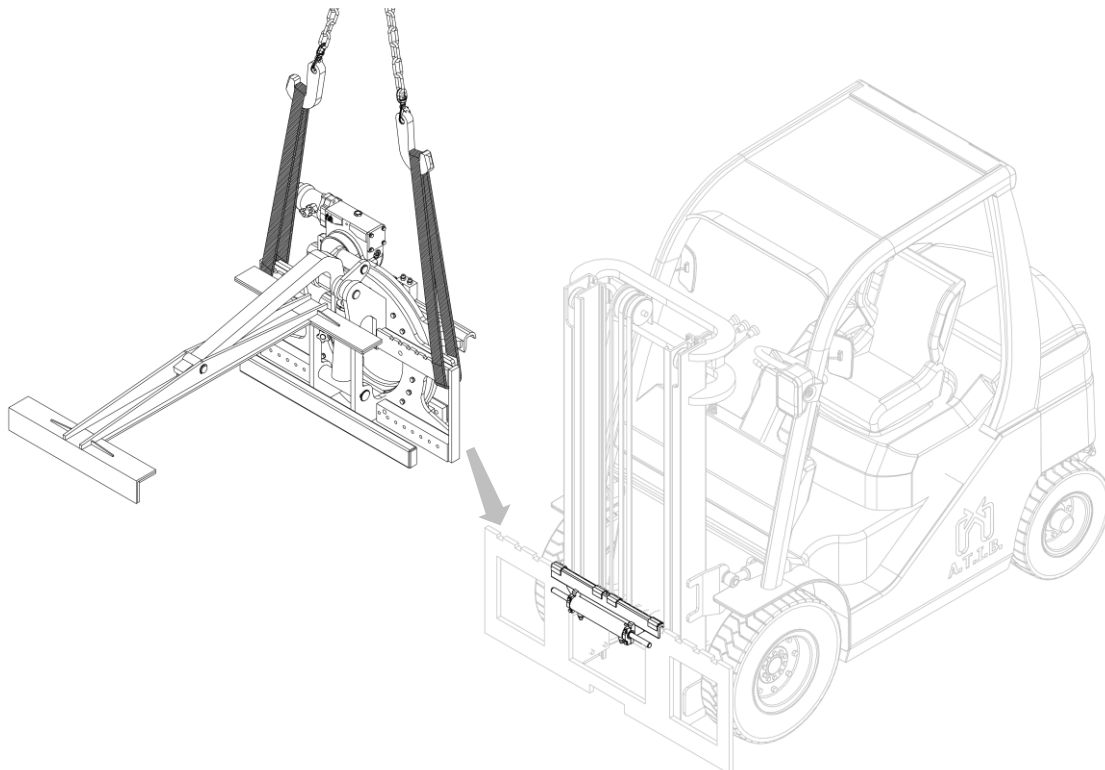

Figure 8

8. Screw on the 2 lower couplings **G** in such a way that their bodies also remains coupled to the lower part of the fork carriage **P** (with max. clearance of 1.5 mm, see detail *Figure 9*), tightening with the torque indicated in *Table 4*.

CLASS	THREAD	TIGHTENING TORQUE
ISO II	M12	90 Nm

Table 4

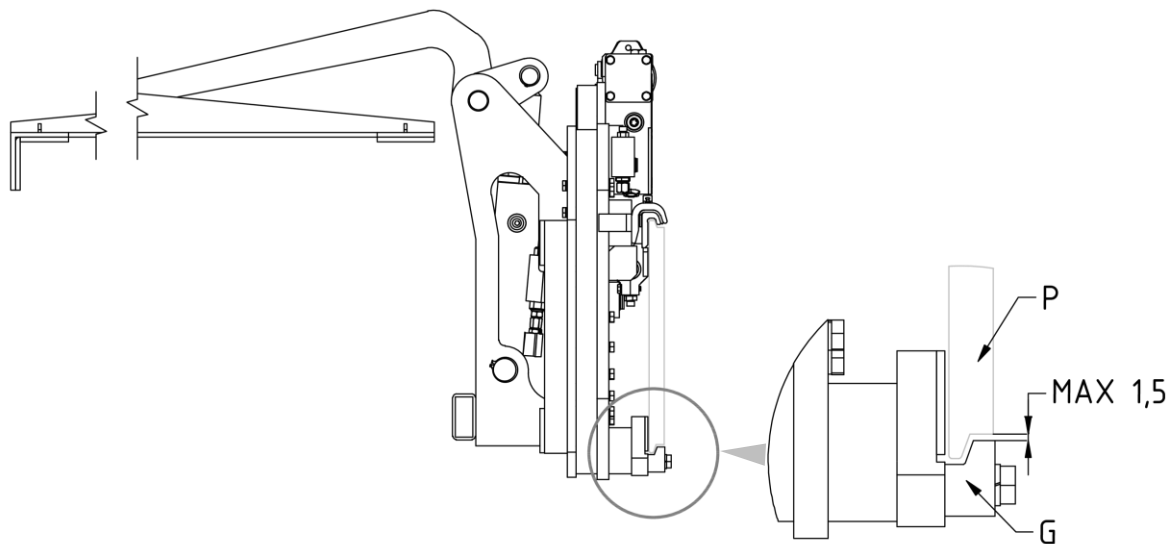

Figure 9

9. Mount the forks (see chapter *Installing the Forks* onto the Equipment on page 18).
10. Lubricate the contact surfaces (see chapter *Lubrication* on page 37).

11. **N.B.** With the equipment mounted, before use, replace the blind iron oil filler plug (F) with the plastic one supplied (P), which includes a breather (see *Figure 10*).

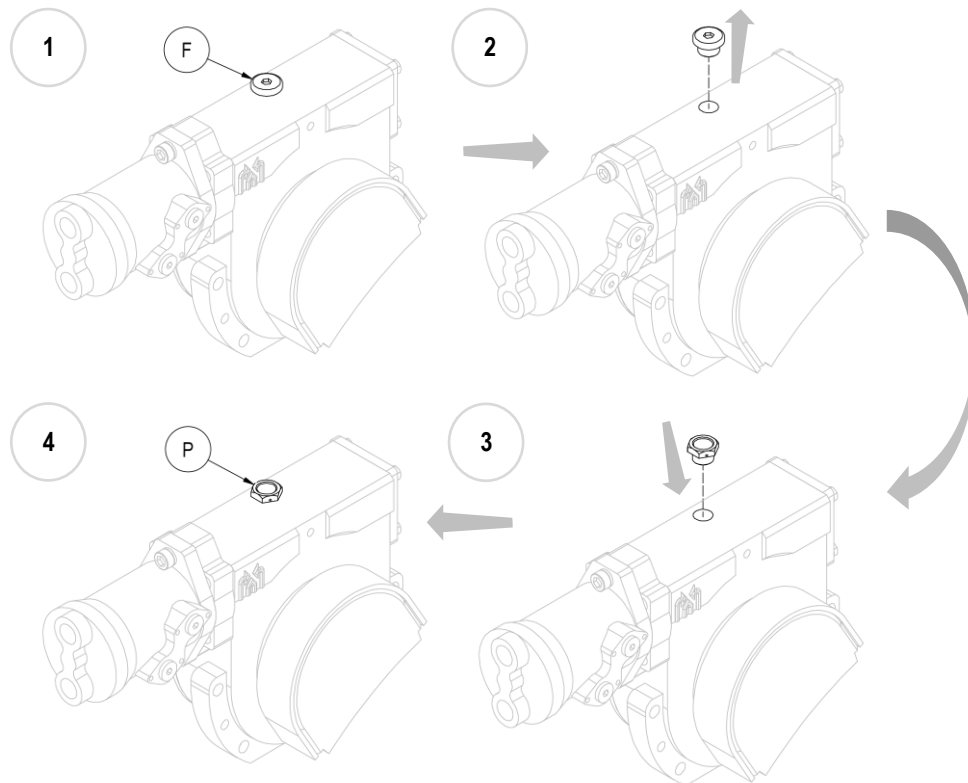

Figure 10

12. Connect the hydraulic circuit, ensuring that the operating pressure of the lines is greater than or equal to that indicated on the rating plate (see *Figure 1* and *Table 1* on page 6).

3.2 Installing the Forks onto the Equipment

1. Attach the forks in the desired position after unscrewing the fork stops (see *Figure 11*).

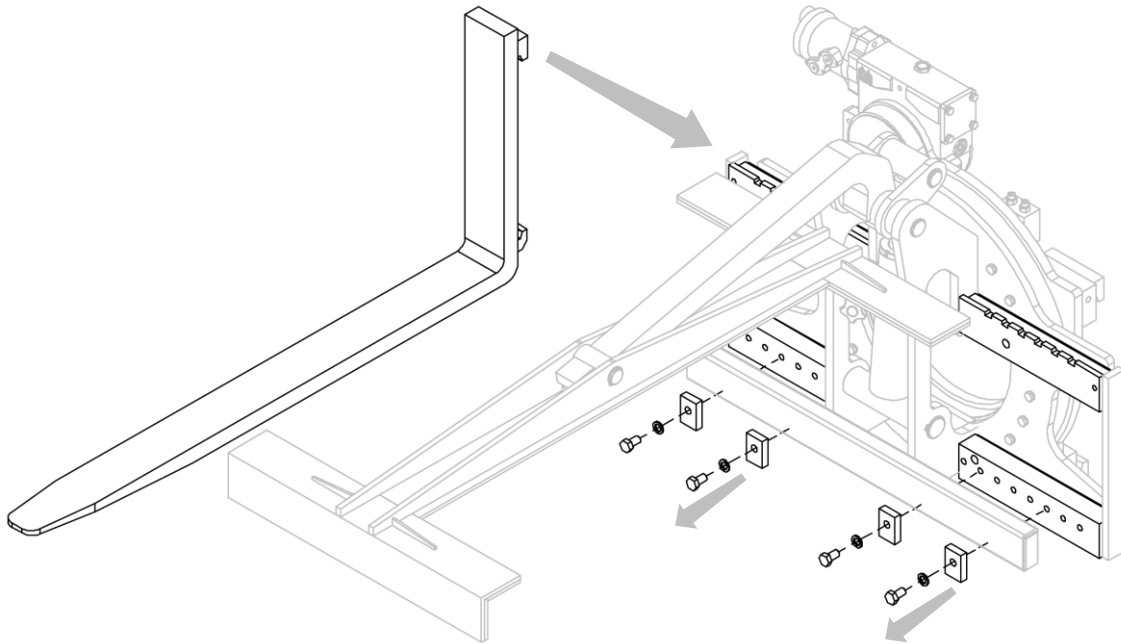

Figure 11

2. Screw in the fork stops once more (see *Figure 12*).

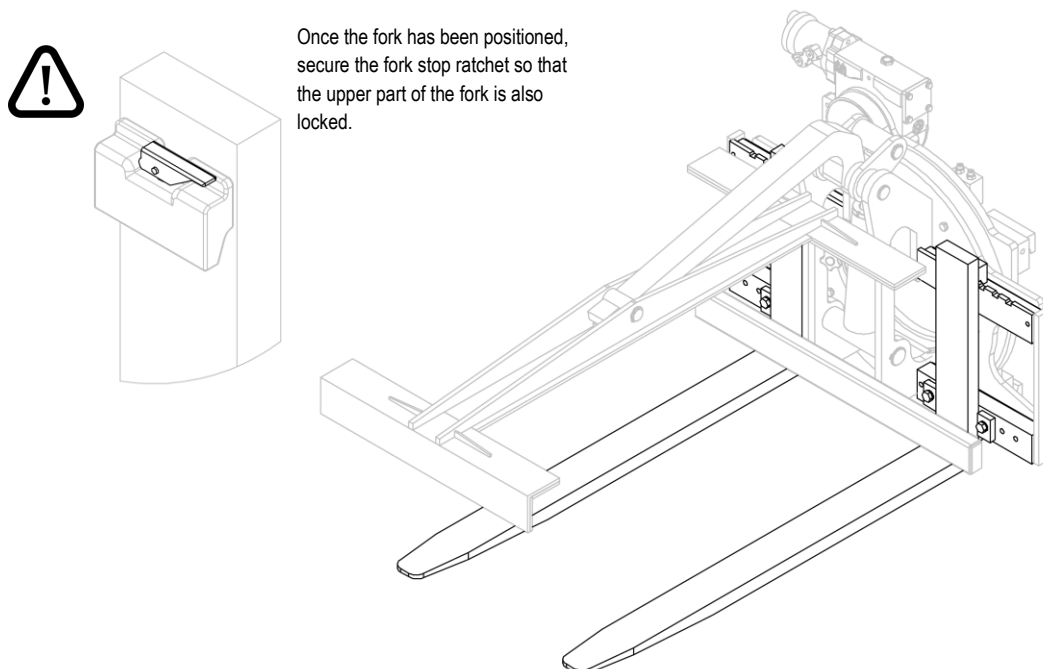

Figure 12

4 HYDRAULIC SYSTEM

4.1 Hydraulic system - Standard

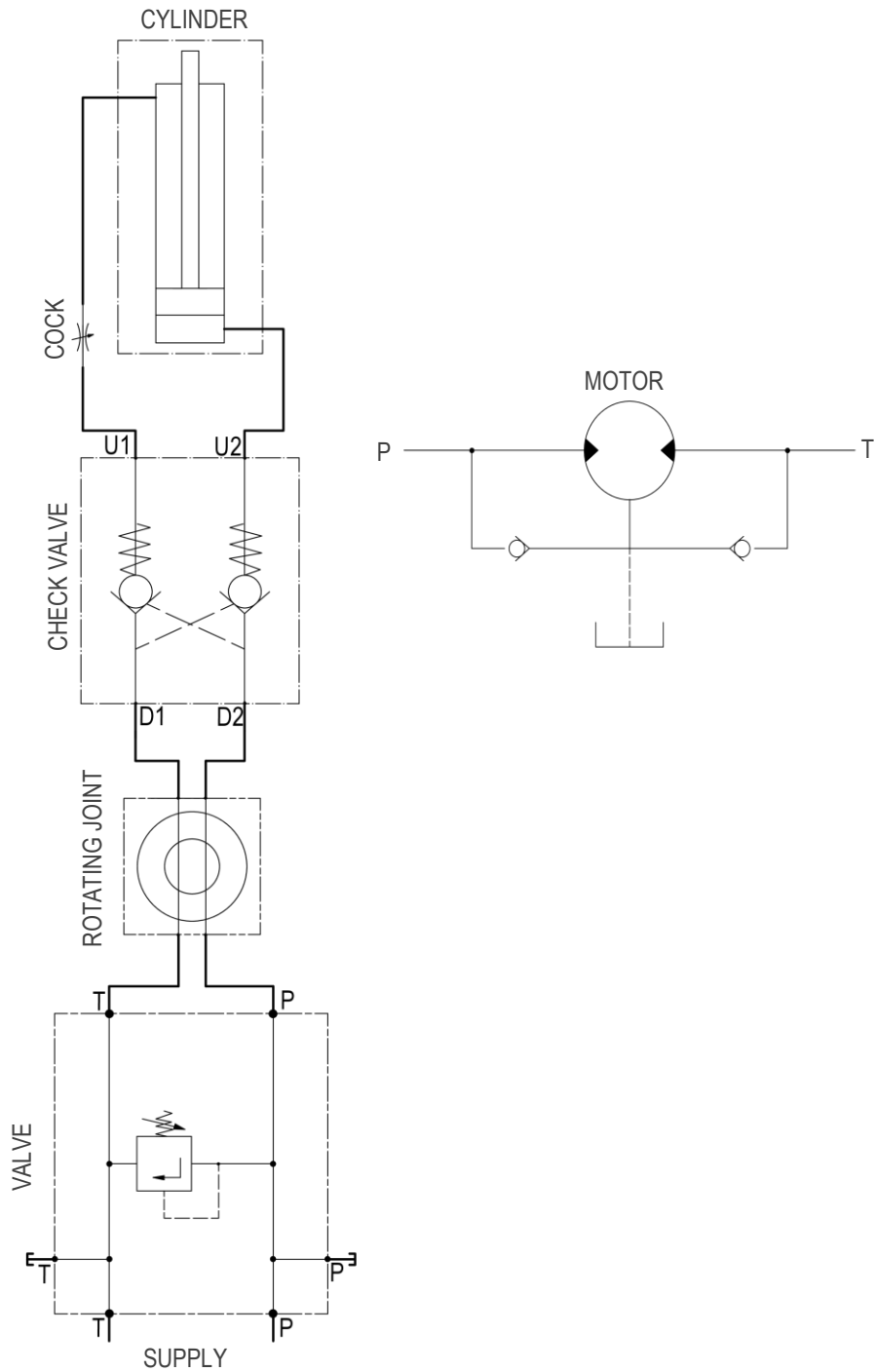

Figure 13

4.2 Hydraulic System - with SISS

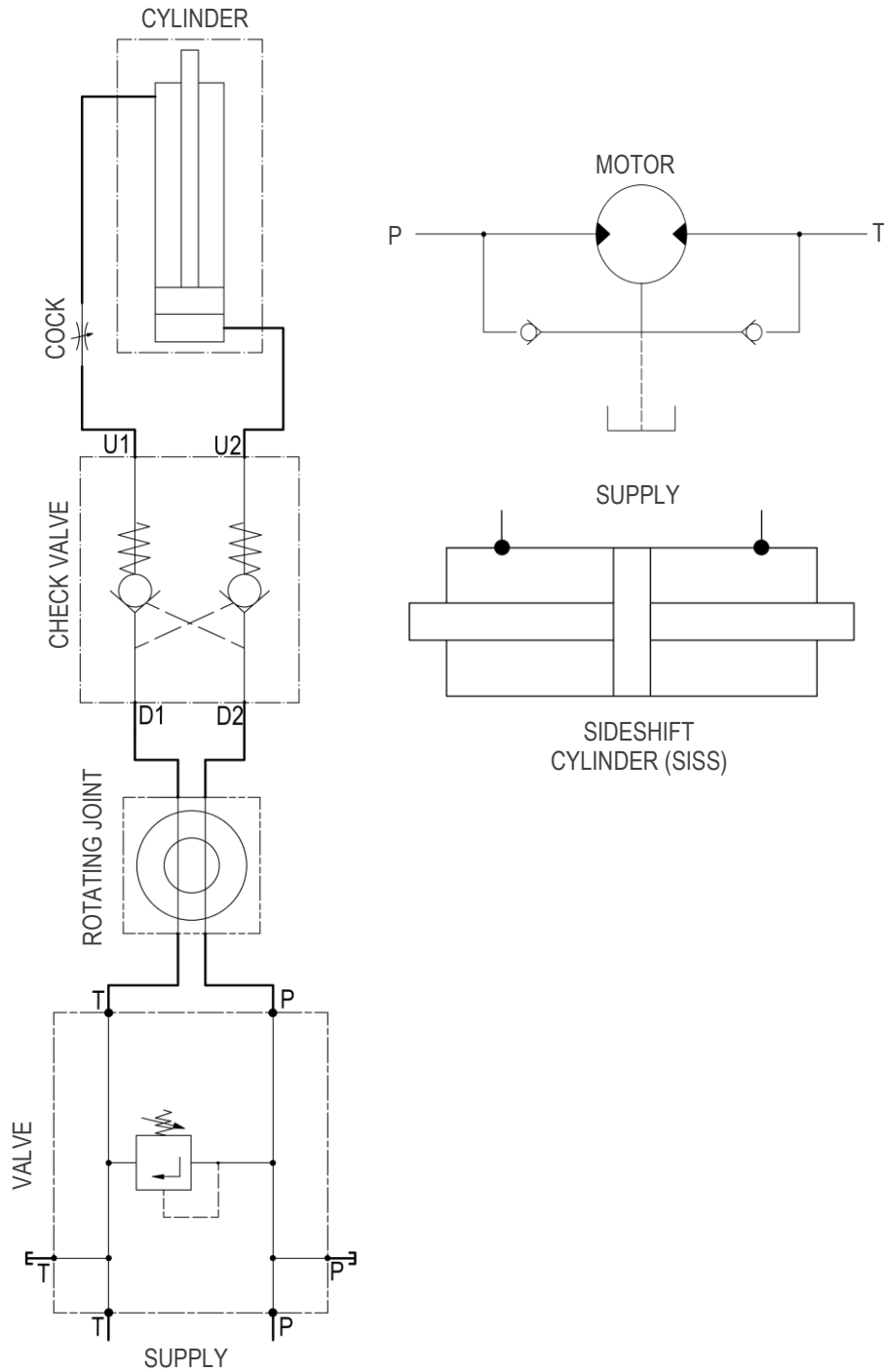

Figure 14

5 RULES GOVERNING USE

Before using the equipment, check the tightness of the piping and the correctness of assembly and also the connection by performing a dozen preliminary operations.

The following instructions must be followed when using the equipment:

1. Observe the capacity limits of the equipment.
2. Do not operate the equipment when persons or animals are within range of the forklift truck.
3. Do not attempt to move loads sideways by dragging them across the floor.
4. Do not exceed the maximum pressure indicated on the rating plate.
5. Operate the equipment from the forklift truck driver's seat using only a single operator.
6. Operate the sideshift control lever gently to avoid water hammer as far as possible.
7. All operations relating to installation, use and maintenance must be carried out by specialist personnel using suitable equipment for the type of work to be carried out.
8. Carry out maintenance and/or repairs with the forklift truck stationary and the hydraulic circuit inactive, using appropriate means of protection (gloves, safety shoes, etc.).
9. Only operate cylinder rods when they are correctly fitted on the equipment;
The rods may otherwise be ejected at great speed by the elevated oil pressures.

The weighted sound pressure level is less than 70 dB (A).

The nominal capacity of the forklift truck/equipment combination is established by the original manufacturer of the forklift truck and may be less than that indicated on the equipment plate.

Consult forklift truck plate (Directive 2006/42/EC).

5.1 Handling Loads

To empty skip loads, proceed as follows:

- Place the forks into the skip and secure it with the retaining plate;
- Lift the load and rotate it until it is empty.



Avoid handling and/or sideshift of the forklift truck/equipment with a load that is excessively high off the ground, as this may affect its stability.



Avoid displacing/handling unstable loads.



Avoid displacing/handling loads with an uncentred centre of gravity.

6 PERIODIC MAINTENANCE

Failure to comply with the rules and intervals established for maintenance will compromise the correct operation of the equipment and will void the conditions of the warranty.

All maintenance operations must be carried out with the forklift truck stationary and the hydraulic circuit disconnected and depressurised. The entire maintenance area must be barricaded using regulation protection devices and, if the cylinders require disassembly, a tray or container must be provided to catch the oil present in the cylinder.

To prevent issues when using the equipment, A.T.I.B. recommends changing the hydraulic oil and filters regularly and keeping the system as clean as possible during maintenance operations.

ATTENTION

Hydraulic parts may be very hot. Use suitable protective equipment.

Watch out for leakage. High-pressure oil can injure eyes and skin. Wear protective eyewear that includes side shields.

Do not remove valves, lines or other potentially pressurised parts when this is active.

6.1 Maintenance Every 100 Hours

1. Check the condition of the hydraulic connections (lines and fittings), replacing worn parts if necessary.
2. Check tightening torque of the bolts of the lower retaining couplings of the equipment, ensuring that it is as indicated in *Table 3* (page 12) and in *Table 4* (page 16) and, if necessary, adjust the bolts holding them in place.
3. Check clearance between the lower part of the fork carriage and the lower equipment couplings, ensuring that it is as shown in *Figure 4* (page 12) and in *Figure 9* (page 16) and, if necessary, adjust the bolts holding them in place.
4. Check that the fork stop securing bolts are properly tightened. Tighten if necessary.
5. Clean and lubricate all sliding parts (see *Figure 26* e *Figure 27* on page 37 e 38).

6.2 Maintenance Every 300 Hours

1. Check condition of bushes and sliding gibs. If excessively worn component are detected, A.T.I.B. recommends replacing the entire component assembly in question.
2. Carry out the additional operations listed in the previous point (*Point 6.1*).

6.3 Maintenance Every 1000 Hours

1. Check condition of bushes and sliding gibs. If excessively worn component are detected, A.T.I.B. recommends replacing the entire component assembly in question.
2. Carry out the additional operations listed in the previous point (*Point 6.1* and *6.2* on page 23).

6.4 Maintenance Every 2000 Hours

1. Carry out a thorough inspection of the equipment. If possible, this should be carried out by qualified personnel who are able to identify any issues that may compromise the safety and efficiency of the equipment. There may be a number of defects, such as the following:
 - Check condition of all equipment components (cylinders, couplings, seals, fittings, grease nipples, etc.) to ensure that they are in good condition and replace any worn parts.
 - Check condition of sliding and working surfaces and replace if damaged.

For further potential issues (and their solutions), refer additionally to *Table 5* on page 36.

2. Dismantle cylinders and check condition of piston rods and seals. If a damaged or excessively worn seal is detected, A.T.I.B. recommends replacing the entire seal assembly.
3. Replace seals in the event of oil leakage and replace rods if they are scratched (cylinders should always be tested when inserted into the equipment to prevent sudden ejection of rods).
4. Carry out the additional operations listed in the previous points (*Point 6.1*, and points *6.2* and *6.3* on page 23).

N.B. Reduce intervals in the event of use under particularly harsh conditions

6.5 Rotation Device Maintenance

6.5.1 Maintenance Every 200 Hours

1. Check the hydraulic connections, replacing any worn parts.
2. Check that the slewing ring securing bolts are tight and tighten, if necessary.
3. Check the oil level of the reduction gearbox using the inspection cap and, if lower than 1/2 the cap, top up with AGIP BLASIA 307 using the oil filler plug.
4. Grease the rotation device using the grease nipples, rotating the equipment slowly. AGIP GR MU/EP2 lithium soap high-pressure grease is recommended (dropping point 205°, ASTM penetration at 235° 250/300).

6.5.2 Maintenance Every 2000 Hours

1. Remove the rotating body by unscrewing the bolts of the slewing ring and replace the felt seals, fitting the new ones with adhesive such as BOSTIK 5242C after cutting them down to size.
2. Check the wear on the slewing coupling components and, if necessary, dismantle and replace as described in point *Disassembling the Slewing Ring*.
3. With the rotating body dismantled, check that the pinion has no worn teeth due to excessive use. If it does, replace.
4. If there is excessive clearance between the pinion and the crown gear, replace the helical gear in the gearbox and/or the pinion.
5. Carry out a full gearbox oil change.

7 DISASSEMBLY PROCEDURE

All maintenance operations must be carried out with the forklift truck stationary and the hydraulic circuit disconnected and depressurised. The entire maintenance area must be barricaded using regulation protection devices and, if the cylinders require disassembly, a tray or container must be provided to catch the oil present in the cylinder.

7.1 Removing the Equipment from the Forklift Truck

1. Release the pressure from the hydraulic system.
2. Remove the lower couplings from the assembly (see *Figure 2 and Figure 7* on page *10 and 15*).
3. For handling, use straps/chains that are suitably sized in relation to the weight of the equipment as indicated on the plate.
4. Then lift the equipment using an overhead crane or hoist of sufficient capacity and remove it from the forklift (see *Figure 3 and Figure 8* on page *11 and 15*).

7.2 Disassembling the Swing Arm

7.2.1 Removing the Plate-Holder Arm

1. Release the pressure from the hydraulic system and disconnect the lines.
2. Remove the pin (with its retaining snap rings and bushes) that secures it to the cylinder.
3. Remove the plate-holder arm after removing the pin that attaches it to the equipment assembly.
4. Use *Figure 15* as a guide.

N.B. Take all necessary precautions to prevent the plate-holder arm from moving during the procedure and compromising overall safety.

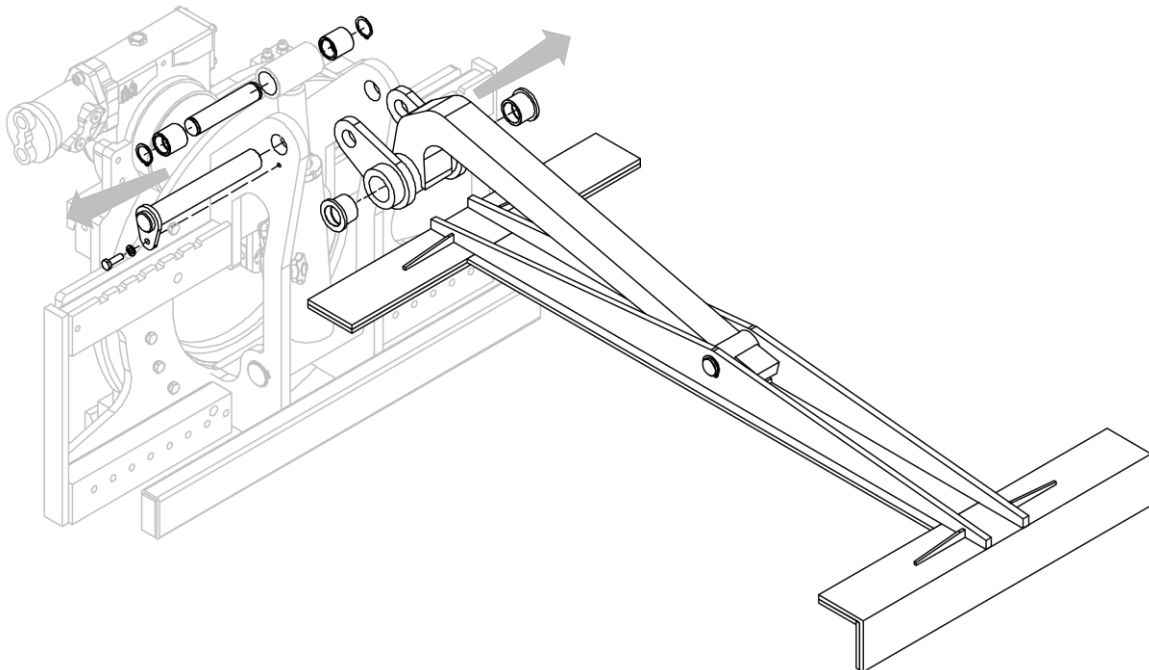

Figure 15

7.2.2 Removing the Skip Retaining Plate

1. Release the pressure from the hydraulic system and disconnect the lines.
2. Remove the plate after removing the pin that attaches it to the corresponding plate-holder arm assembly.
3. Use *Figure 16* as a guide.

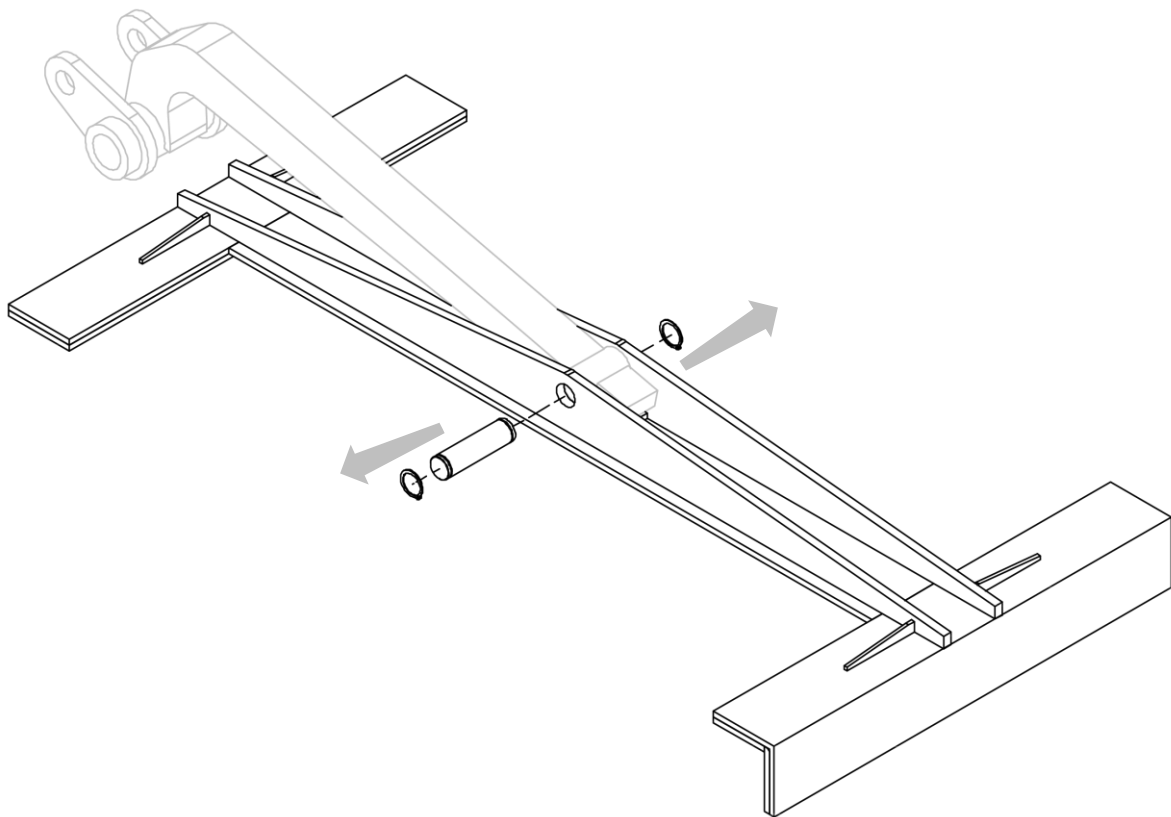

Figure 16

7.3 Removing the Forks from the Equipment

1. Release the pressure from the hydraulic system and disconnect the lines.
2. Remove the forks after unscrewing the fork stops and opening the fork-stop ratchets (see *Figure 17* and *Figure 18*).

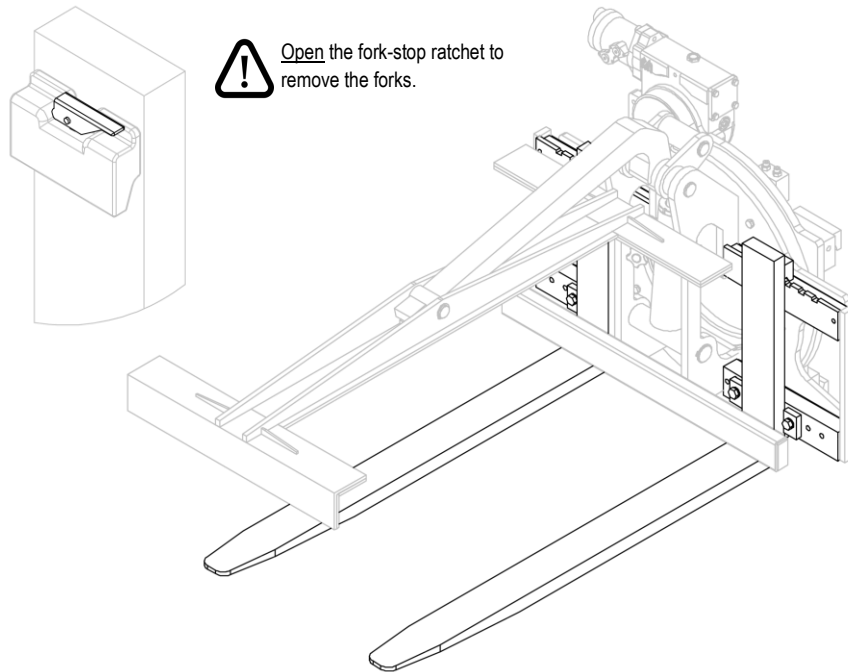
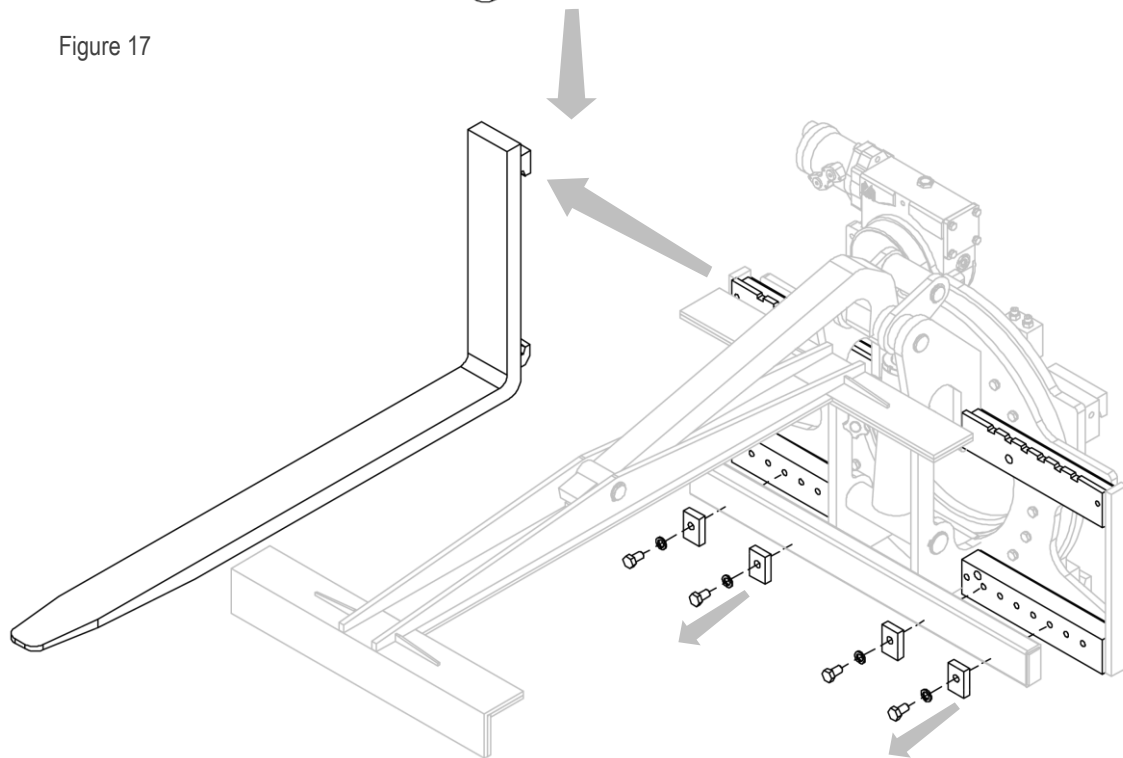

Figure 17



7.4 Removing the Plate Articulation Cylinder

1. Release the pressure from the hydraulic system and disconnect the lines.
2. Remove the pin (with its corresponding retaining snap rings) that secures the cylinder to the plate-holder arm.
3. Remove the cylinder after removing the pin (with its corresponding retaining snap rings and bushes) that secures it to the equipment assembly.
4. Use *Figure 19* as a guide.

N.B. Take all necessary precautions to prevent the plate-holder arm from moving during the procedure and compromising overall safety.

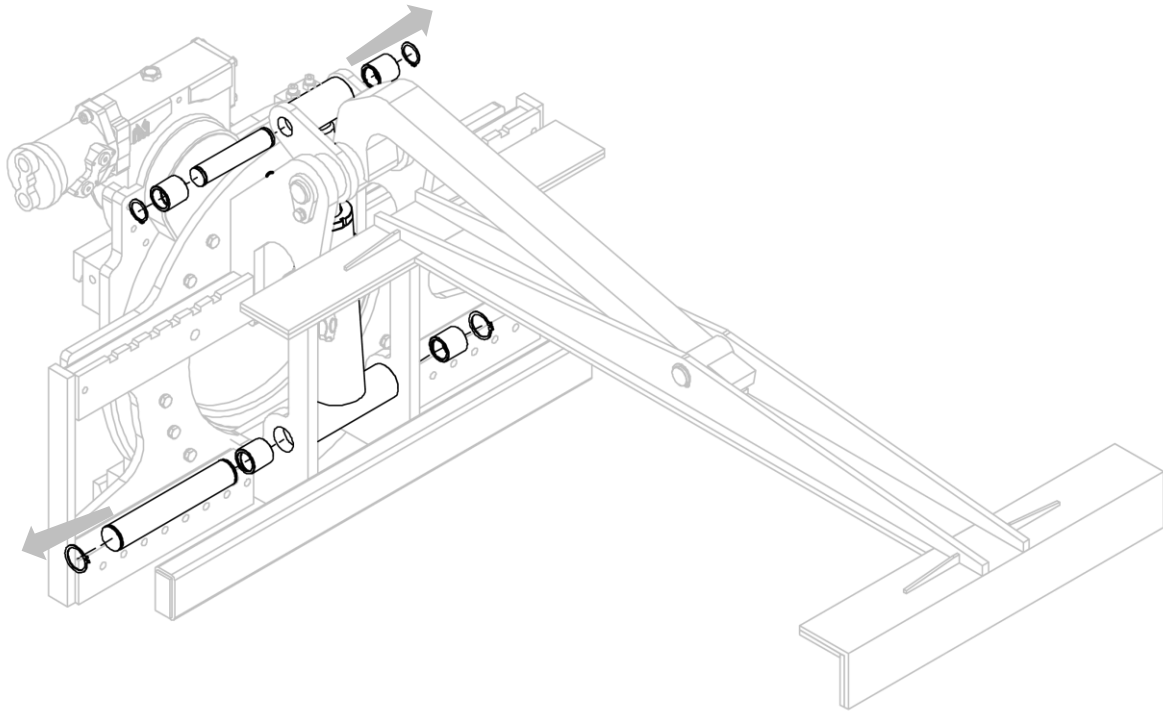

Figure 19

7.4.1 Disassembling and Reassembling the Cylinder

If the entire cylinder needs to be replaced, reassemble following the instructions listed in the previous point. If any cylinder components need to be replaced, proceed as indicated below:

1. Clamp the cylinder body in a vice using soft jaws (taking care not to deform the liner).
2. Use a C-hook spanner to remove cap **T**.
3. If the cap will not unscrew, slightly heat the area of the thread in question to facilitate unscrewing.
4. Separate the rest of the components and seals (the piston can be either welded or screwed to the piston rod **S**).
5. Replace damaged parts and reassemble by repeating the above steps in reverse order, taking care to relock the cylinder cap using medium strength threadlocker.
6. If a damaged seal is found, it is advisable to replace the entire seal assembly.
7. Use *Figure 20* as a guide.

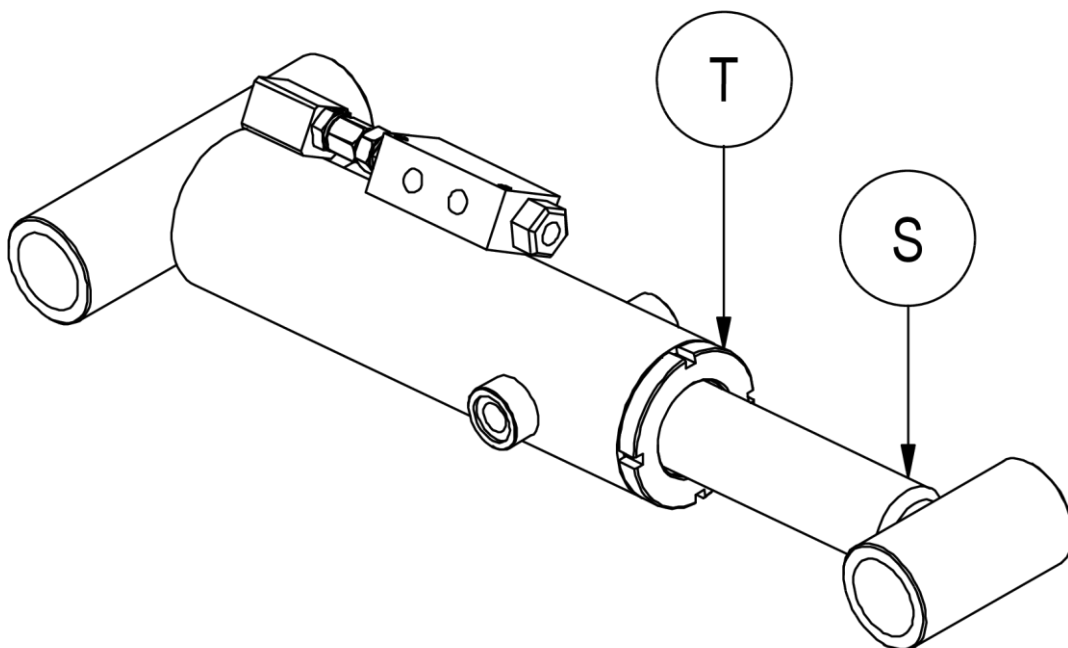

Figure 20

7.5 Removing the Sideshift Cylinder - SISS TYPE

1. Release the pressure from the hydraulic system and disconnect the lines, ensuring that a tray or container is made available beneath the fittings to catch the oil in the cylinder.
2. Remove the equipment from the forklift truck (see *Removing the Equipment from the Forklift Truck* on page 26).
3. Remove the cylinder from its housing after removing the front half-collar and the corresponding bolts/pins (depending on type) that secure it.
4. Use *Figure 21* as a guide.

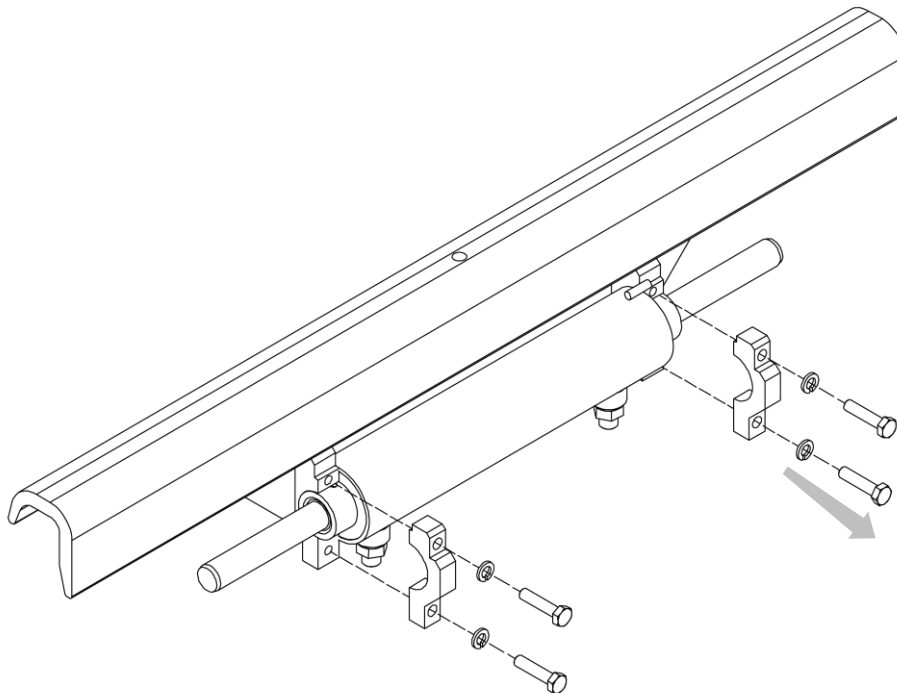

Figure 21

7.5.1 Disassembling and Reassembling the Cylinder

If the entire cylinder needs to be replaced, reassemble following the instructions listed in the previous point in reverse order (using the new cylinder). If any cylinder components need to be replaced, proceed as indicated below (see *Figure 22*):

1. Place the cylinder on a horizontal surface.
2. If only the rods need to be replaced, simply remove them from the cylinder cap.
3. If seals and/or other parts need to be replaced, the cap must be unscrewed using a C-hook spanner.
4. If the cap will not unscrew, slightly heat the area of the thread in question to facilitate unscrewing.
5. Replace damaged parts and reassemble by repeating the above steps in reverse order, taking care to relock the cylinder cap using medium strength threadlocker.
6. If a damaged seal is found, it is advisable to replace the entire seal assembly.

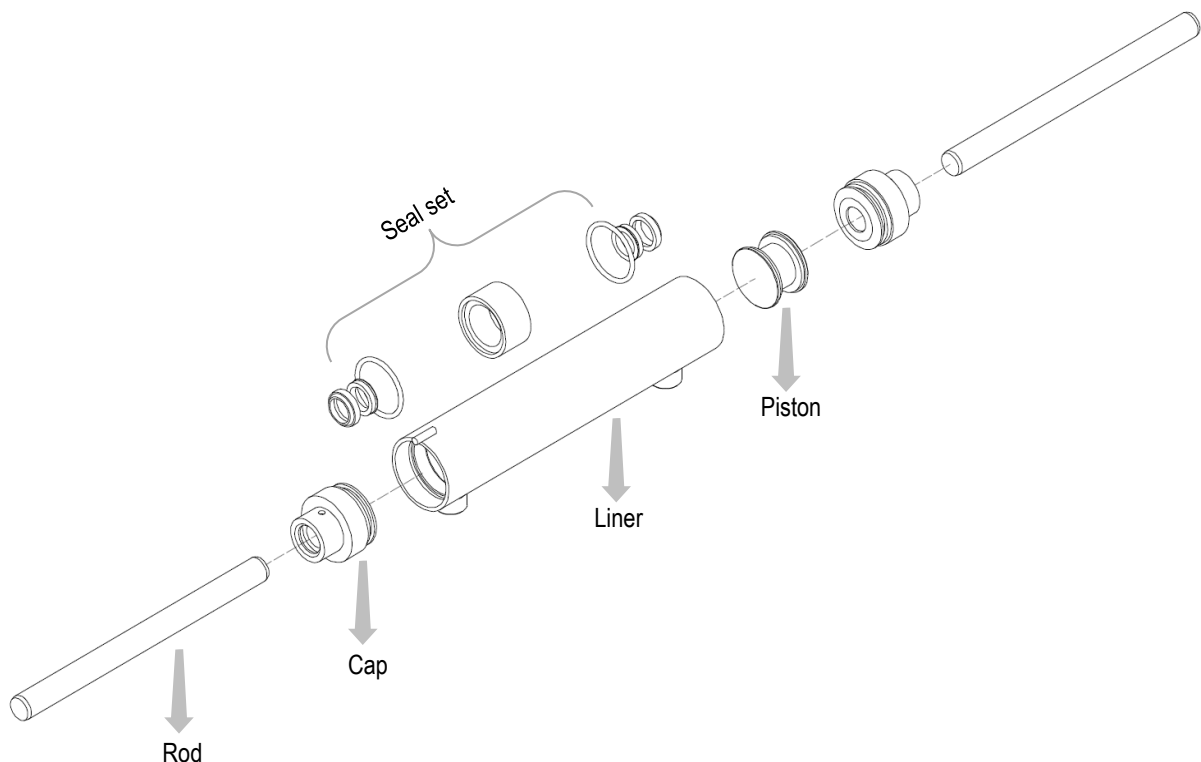

Figure 22

7.6 Disassembling the Gearbox and Motor

1. Release the pressure from the hydraulic system and disconnect the lines.
2. Remove the equipment from the forklift truck (see *Removing the Equipment from the Forklift Truck*).
3. Remove the gearbox-motor pair from the equipment assembly, after removing the corresponding bolts (see *Figure 23*).

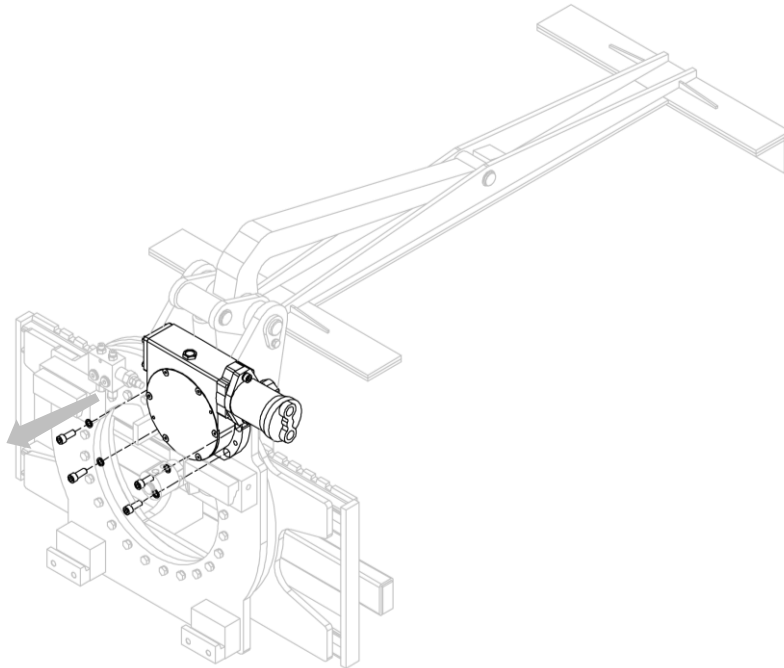

Figure 23

4. Separate the motor from the gearbox, after having removed the bolts that secure it (see *Figure 24*).

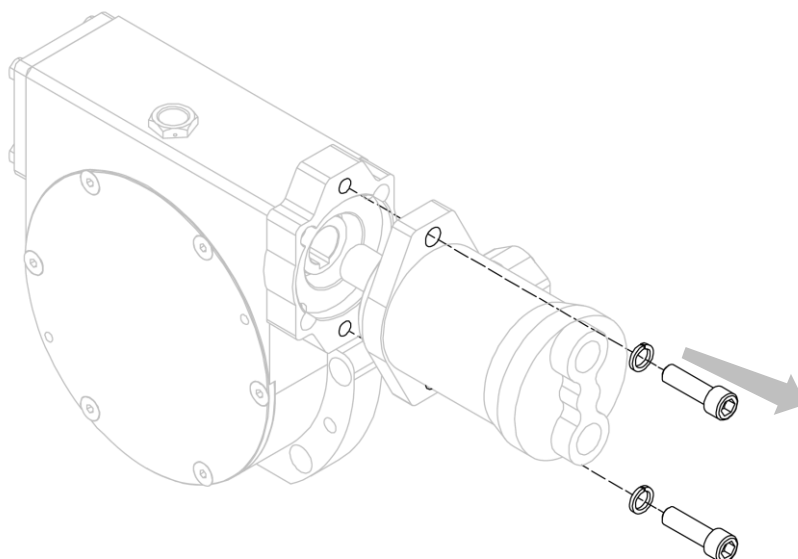

Figure 24

7.7 Disassembling the Slewing Ring

1. Release the pressure from the hydraulic system and disconnect the lines.
2. Remove the equipment from the forklift truck (see *Removing the Equipment from the Forklift Truck*).
3. Remove the gearbox and motor from the equipment (see Point 3 of chapter *Disassembling the Gearbox and Motor*).
4. Remove the plate-holder arm and press cylinder (see chap. *Removing the Plate-Holder Arm* and *Removing the Plate Articulation Cylinder* on page 27 and 30).
5. Remove the front part of the rotating body, ensuring that all parts are supported to carry out the procedure in safety (see *Figure 25*).
6. To remove the slewing ring **R**, the bolts on the rear of the equipment must also be removed (see *Figure 25*).
7. Check the condition of the slewing ring and fit a new one if necessary.
8. Reassemble following the instructions listed above, remembering to replace the felt seals **G** with new ones, which must be fitted using adhesive such as BOSTIK 5242C.

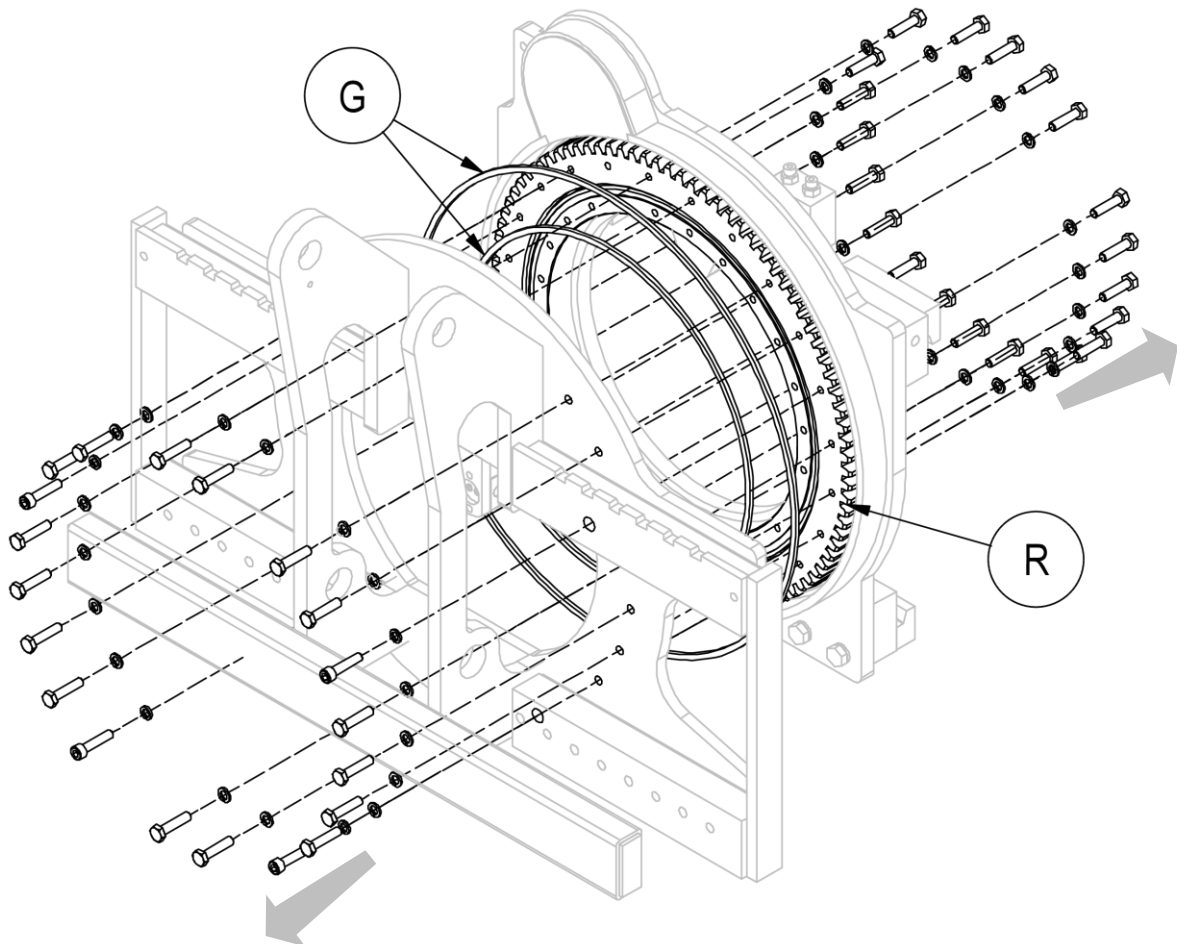

Figure 25

8 TROUBLESHOOTING

8.1 Probable Faults and Solutions

FAULT	CAUSE	SOLUTION
Insufficient pressure on load	Calibration of the maximum pressure valve too low	Increase the pressure without exceeding the maximum limit
	Insufficient pressure	Contact the forklift truck manufacturer
	Worn pump	Replace it
	Worn cylinder seals	Replace them
	No oil in the tank	Fill up
Pressure drop on clamped load	Oil leakage through pipes and fittings	Tighten the fittings or replace them
	Oil leakage from the cylinders	Replace the seals or, if necessary, the cylinders
	Load loss in sideshift	Lower sideshift pressure
	Load loss	Check fork camber
Drive response slow	Low oil flow rate	Check the tank level and/or the pump Constrictions in the system: search for them and remove them
	Insufficient pressure	Adjust the calibration of the maximum pressure valve
	Mechanical deformations of some parts	Repair or replace
	Worn cylinder seals	Replace them
	No oil in the tank	Fill up
	Air in hydraulic system	Purge system
Erratic displacement	Worn gibs or sliding rollers	Replace
	Excessive friction between sliding parts	Clean and grease sliding parts
	Worn cylinder seals	Replace them
	Rotation trigger	Reduce load eccentricity
	No oil in the tank	Fill up
	Rotation device	Noise and/or vibrations
Hydraulic motor worn out		Replace motor

Table 5

For further issues, contact A.T.I.B. S.r.l.

8.2 Lubrication

1. Lubricate sliding components using grease nipples.
2. Lubricate bushes and sliding gibs
3. Lubricate sliding surfaces.
4. Also lubricate slewing ring using grease nipples.

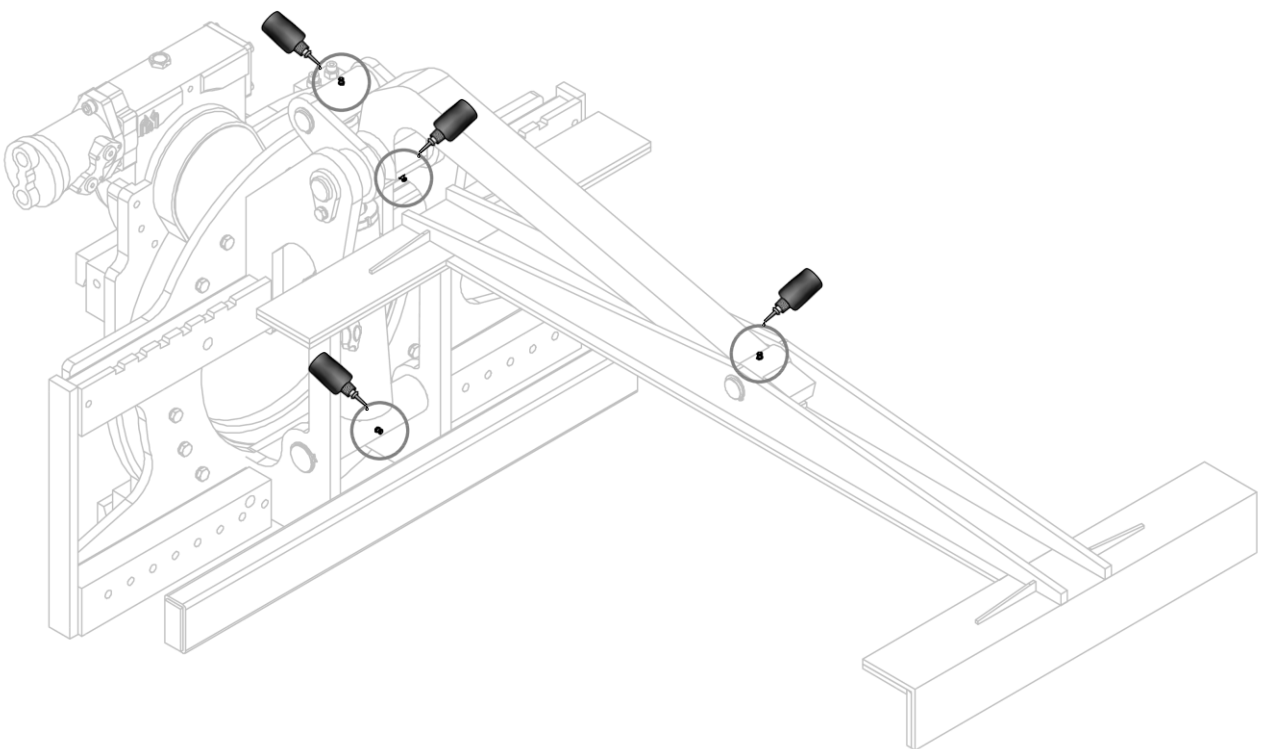

Figure 26

TYPE 213 SISS

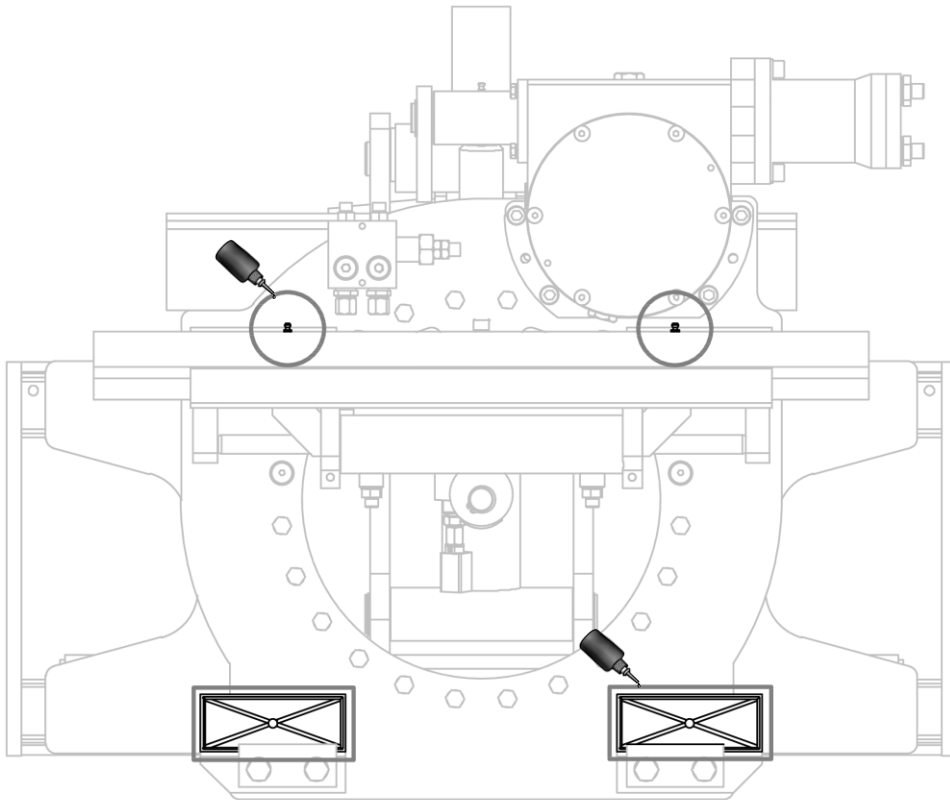

Figure 27

A.T.I.B. S.r.l.

Via Quinzanese snc, 25020 Dello (BS) - ITALY

+39 030 977 17 11

info@atib.com

atib.com

