



**ATiB** MATERIAL  
HANDLING

# USE AND MAINTENANCE MANUAL

BALE CLAMP WITH THIN BLADES TYPE 474.131 |

BALE CLAMP WITH CRIMPED BLADES TYPE 474.130 |

CLAMP FOR FOAM RUBBER BLOCKS TYPE 474.195

# TABLE OF CONTENTS

**BALE CLAMP WITH THIN BLADES TYPE 474.131 |**  
**BALE CLAMP WITH CRIMPED BLADES TYPE 474.130 |**  
**CLAMP FOR FOAM RUBBER BLOCKS TYPE 474.195**



**READ THIS USE AND MAINTENANCE MANUAL CAREFULLY BEFORE  
COMMISSIONING THE MACHINE**

<b>1</b>	<b>SAFETY REGULATIONS FOR THE OPERATOR.....</b>	<b>3</b>
<b>2</b>	<b>INTRODUCTION .....</b>	<b>4</b>
2.1	Use and Storage of the Manual.....	4
2.2	Equipment Description.....	5
<b>3</b>	<b>INSTALLATION .....</b>	<b>10</b>
3.1	Installation Procedure .....	11
3.1.1	Installing the Equipment.....	11
3.1.2	Installing the Equipment - With Siss.....	14
3.2	Assembling the Aluminium Profiles.....	17
3.3	Assembling the Nylon Bushes.....	18
3.4	Assembling the Jaws.....	19
3.4.1	Assembling the Jaws onto the Equipment.....	19
<b>4</b>	<b>HYDRAULIC SYSTEM.....</b>	<b>20</b>
4.1	Hydraulic System - Valve B2383022 .....	20
4.2	Hydraulic System - Valve B2383022 with Siss.....	21
4.3	Hydraulic System – Iss – Valve B2383023 .....	22
<b>5</b>	<b>RULES GOVERNING USE .....</b>	<b>23</b>
5.1	Integral Sideshift.....	26
5.2	Handling Loads .....	27
<b>6</b>	<b>PERIODIC MAINTENANCE.....</b>	<b>28</b>
6.1	Maintenance Every 100 Hours .....	28
6.2	Maintenance Every 300 Hours .....	28
6.3	Maintenance Every 1000 Hours .....	29
6.4	Maintenance Every 2000 Hours .....	29
<b>7</b>	<b>DISASSEMBLY PROCEDURE.....</b>	<b>30</b>

7.1	Removing the Equipment from the Forklift Truck.....	30
7.2	Disassembling the jaws.....	31
7.2.1	Removing the Jaws from the Equipment .....	31
7.3	Disassembling the Nylon Bushes.....	32
7.4	Disassembling the Aluminium Profiles .....	33
7.5	Removing the Clamping Cylinders from the Equipment .....	34
7.5.1	Disassembling and Reassembling the Clamping Cylinders .....	36
7.6	Sideshift Cylinder Maintenance (siss).....	37
<b>8</b>	<b>TROUBLESHOOTING .....</b>	<b>39</b>
8.1	Probable Faults and Solutions.....	39
8.2	Lubrication .....	40

# 1 SAFETY REGULATIONS FOR THE OPERATOR



Do not transport passengers



Do not cross the upright



Do not stand under the load

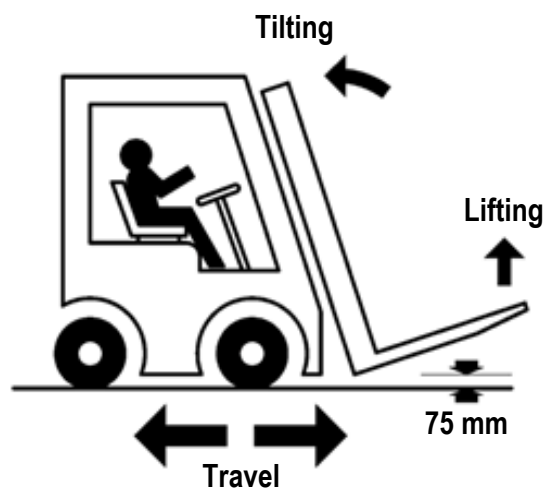

## 2 INTRODUCTION

### 2.1 Use and Storage of the Manual

This "Use and Instruction Manual" (hereinafter referred to as the Manual) is issued together with the A.T.I.B. equipment. - "BALE CLAMP WITH THIN BLADES TYPE 474.131 | BALE CLAMP WITH CRIMPED BLADES TYPE 474.130 | CLAMP FOR FOAM RUBBER BLOCKS TYPE 474.195" in accordance with DIRECTIVE 2006/42/EC OF THE EUROPEAN PARLIAMENT AND OF THE COUNCIL of 17/05/2006 and subsequent additions.

The following indications are essential for correct use of the equipment and must be brought to the attention of the personnel assigned to installation, use, maintenance and repair.

This Manual must be considered an integral part of the equipment and must be kept until it is dismantled in an accessible, protected and dry place and must be available for quick reference.

In the event of loss and/or damage, the user can request a copy from the manufacturer.

The manufacturer reserves the right to modify this manual without prior notice and without the obligation to update previously distributed copies.

The manufacturer is exempted from any responsibility in the event of:

- Improper use of equipment;
- Use of equipment by untrained personnel;
- Use contrary to any national or international regulations;
- Inadequate scheduled maintenance;
- Unauthorised intervention or modification;
- Use of non-original and/or non-model specific spare parts;
- Full or partial non-compliance with instructions;
- Exceptional events.

The nominal capacity of the forklift truck/equipment combination has been set by the original manufacturer of the forklift truck and may be less than that indicated on the equipment plate.  
Consult forklift truck plate (Directive 2006/42/EC).

## 2.2 Equipment Description

TYPE 474.131

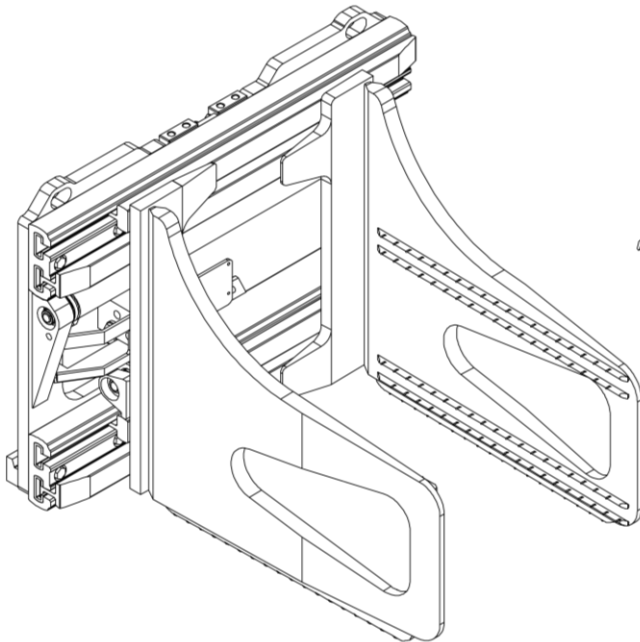

TYPE 474,131 WITH

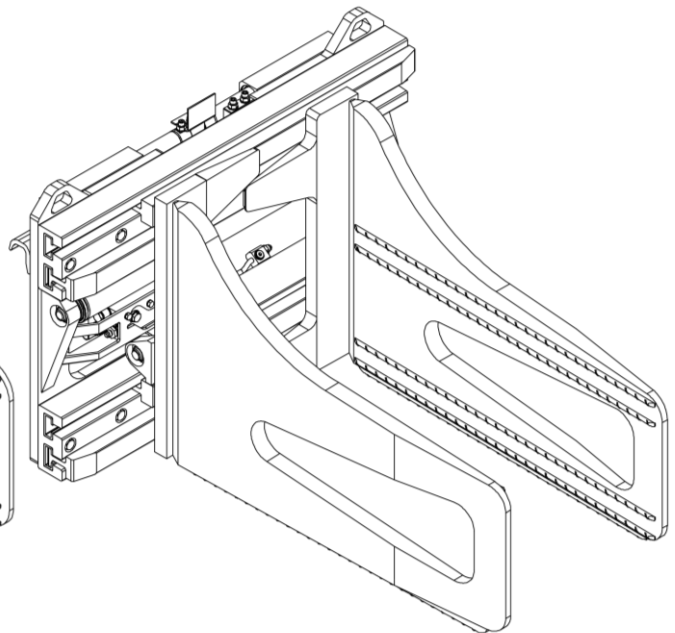

TYPE 474.130

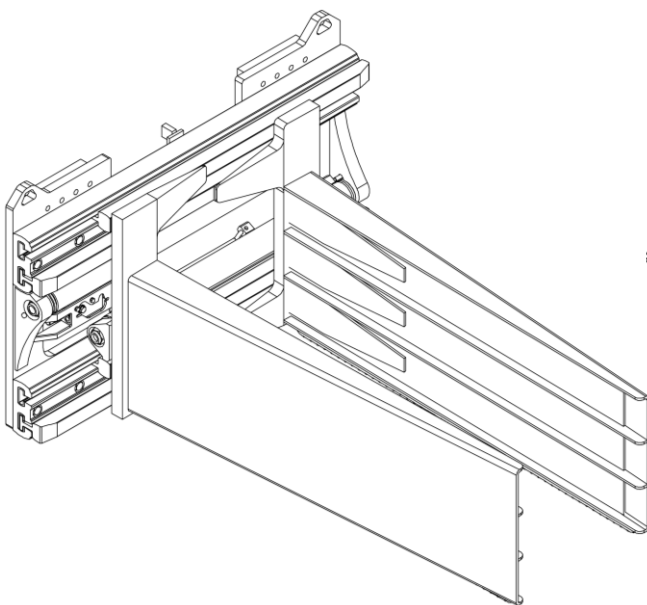

TYPE 474.130 WITH SISS

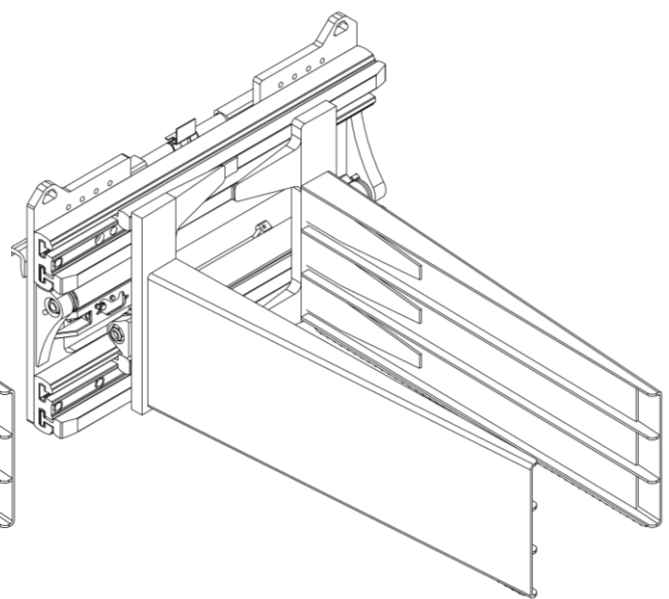

TYPE 474.195

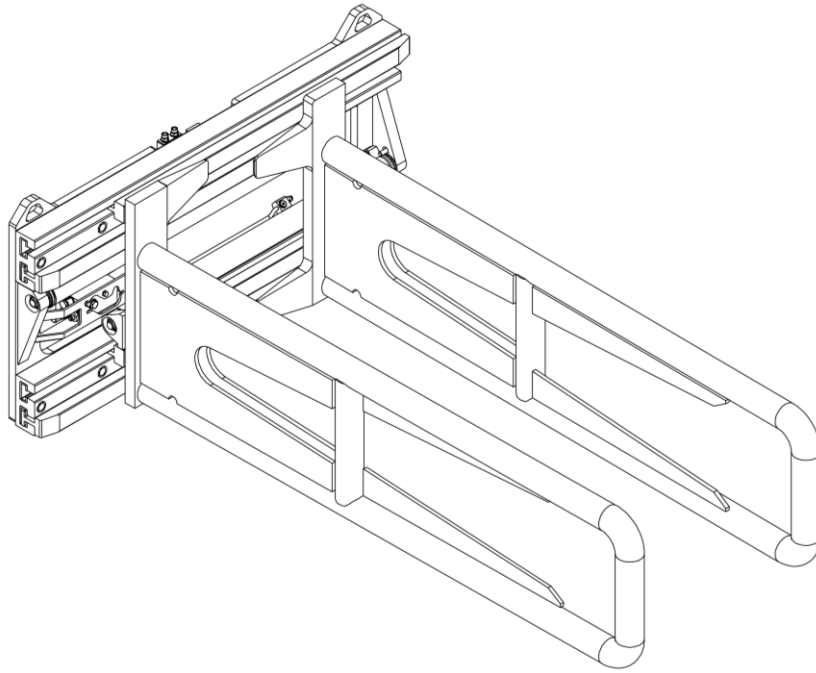

TYPE 474.195 WITH SISS

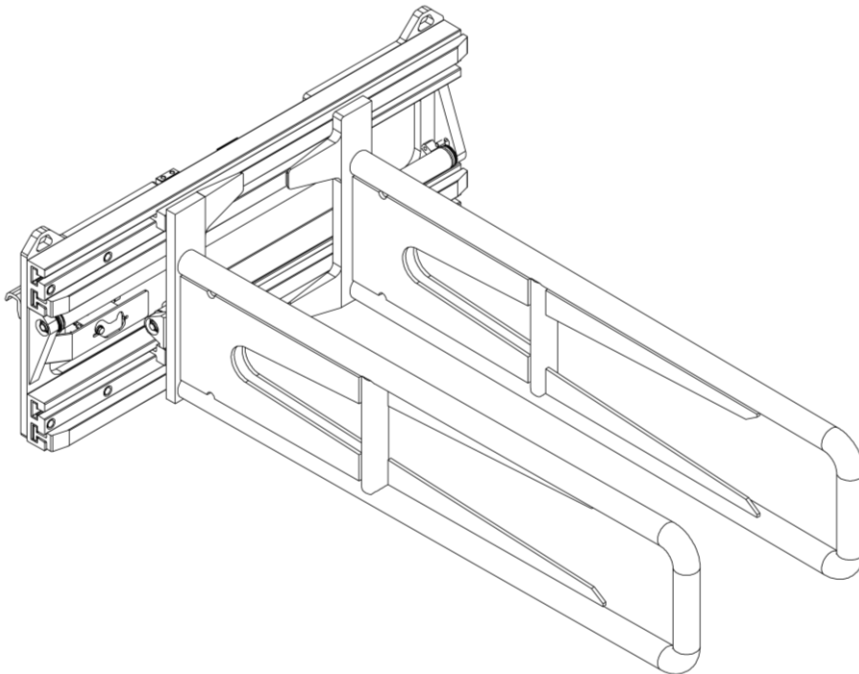

All the A.T.I.B. equipment – “BALE CLAMP WITH THIN BLADES TYPE 474.131 | BALE CLAMP WITH CRIMPED BLADES TYPE 474.130 | CLAMP FOR FOAM RUBBER BLOCKS TYPE 474.195” are identified by means of an adhesive plate (see *Table 1*) located on the equipment (see *Figure 1*), always refer to the serial number.

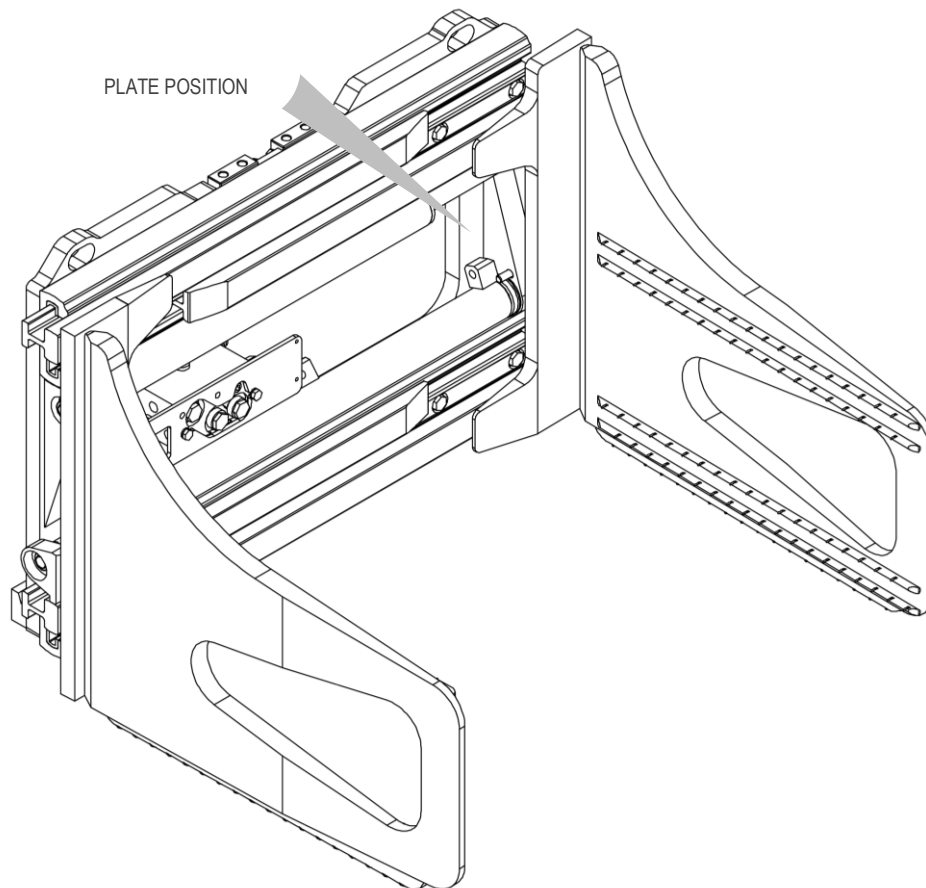

Figure 1



1. TIPO / TYPE	8. PORTATA NOMINALE / NOMINAL CAPACITY	kg/mm	11. COPPIA MAX / MAX. TORQUE	daNm
2. CODICE / CODE	9. PORTATA IN SERRAGGIO / CLAMPING CAPACITY	kg/mm		
3. MATRICOLA N° / SERIAL N°				
4. ANNO DI COSTRUZIONE / YEAR OF MANUFACTURE	10. PRESSIONE MAX. DI ESERCIZIO / MAX. OPERATING PRESSURE	bar	<b>A.T.I.B. S.r.l.</b> Via Quinzanese snc, 25020 Dello (BS) - ITALY +39 030 9771711 info@atib.com - atib.com	
5. PESO / WEIGHT				
6. SPESSORE / THICKNESS	NOTE: OSSERVARE I LIMITI DI PORTATA DELL'INSIEME CARRELLO CON ATTREZZATURA / WARNING: OBSERVE THE NOMINAL CAPACITY OF TRUCK AND ATTACHMENT COMBINED			
7. CENTRO DI GRAVITÀ / CENTER OF GRAVITY				

Table 1



1. **TYPE**  
Indicates equipment model as shown in the catalogue.
2. **CODE**  
Indicates the equipment ordering code.
3. **SERIAL N°**  
It progressively identifies the individual equipment.  
In the event that the plate is missing or is damaged, the serial number is also stamped on the profile for connection to the fork-holder plate; for any information always refer to the serial number.
4. **YEAR OF MANUFACTURE**  
Indicates the year of manufacture.
5. **WEIGHT**  
Indicates the weight of the equipment in kg.
6. **THICKNESS**  
Indicates the thickness of the equipment in mm.
7. **CENTRE OF GRAVITY**  
Indicates the distance in mm of the *CG* centre of gravity of the equipment from the support plane of the fork-holder plate.
8. **NOMINAL CAPACITY**  
Indicates the maximum load applicable to the lifting equipment and the maximum centre of gravity of the load itself.
9. **CLAMPING CAPACITY**  
Indicates the maximum weight that can be lifted via clamping.
10. **MAX. OPERATING PRESSURE**  
Indicates the maximum pressure expressed in bar at which the equipment can work.
11. **MAX. TORQUE**  
Not applicable to this equipment.

The A.T.I.B. equipment - “BALE CLAMP WITH THIN JAWS TYPE 474.131” has been conceived, designed and manufactured to grip and/or handling of bales of any material type (paper, cardboard, scrap, plastic and other materials).

The A.T.I.B. equipment - “BALE CLAMP WITH CUSHIONED JAWS TYPE 474.130” has been conceived, designed and manufactured to grip and/or handle bulky loads of all types.

The A.T.I.B. equipment - “FOAM RUBBER CLAMP TYPE 474.195” has been conceived, designed and manufactured to grip and/or handle bulky loads, such as foam rubber or expanded foam items.

ISS = with INTEGRAL SIDESHIFT

SISS = with SEMI-INTEGRAL SIDESHIFT

This equipment must be attached to the fork carriage of the forklift truck and connected to the distributor via a hydraulic circuit.

The relative movement for adjusting the distance between the jaws is achieved by means of two hydraulic cylinders.

Semi-integral sideshift motion between the parts attached to the fork carriage and those attached to the lifting equipment is carried out by two hydraulic cylinders.

Integral sideshift motion is carried out by a special valve and uses the same cylinders that handle the jaws.

Fork carriage coupling components are manufactured in accordance with ISO 2328.

### 3 INSTALLATION

#### Checking the Nominal Capacity of the Equipment

To check the nominal capacity of the clamp, refer to the clamp's rating plate (See *Table 1* on page 7).



Ensure that the driver of the forklift truck is aware of the maximum capacity of the equipment so that they do NOT constitute a hazard to themselves or to persons working in proximity.

The forklift truck manufacturer is responsible for calculating the residual load capacity of the truck/equipment combination.

#### Checking the Operating Pressure and Oil Flow Rate

A.T.I.B. recommends observing the hydraulic flow rates and operating pressures provided in *Table 2*, to optimise operation of the equipment and avoid issues during work or commissioning. Values are for indicative purposes only and may vary depending on the equipment.

TYPE and ISO	FLOW RATE (l/mm)			Operating pressure Maximum (Bar)
	minimum	maximum	recommended	
474.131 ISO II	10	40	20	175
474.131 ISO III	15	40	25	175
474.130 ISO II	10	40	20	175
474.130 ISO III	15	40	25	175
474.195 ISO II	10	40	20	175

Table 2



**OBSERVE THE INDICATED MAXIMUM OPERATING PRESSURES**

## 3.1 Installation Procedure

### 3.1.1 Installing the Equipment

(NO SISS)

1. Prior to installation, check the condition of the fork carriage, ensuring that the lower profile is smooth.

2. Also make sure that the profiles of the fork-holder plate are not deformed, in order to ensure good coupling with the equipment.

3. Check the condition of the pipes, replacing those in a poor condition.

**N.B.** Although only type 474.131 is shown in the installation phase, the equipment installation procedure is identical for different versions (.130/.195, WITHOUT SISS).

4. Remove the lower couplings from the equipment (see *Figure 2*).

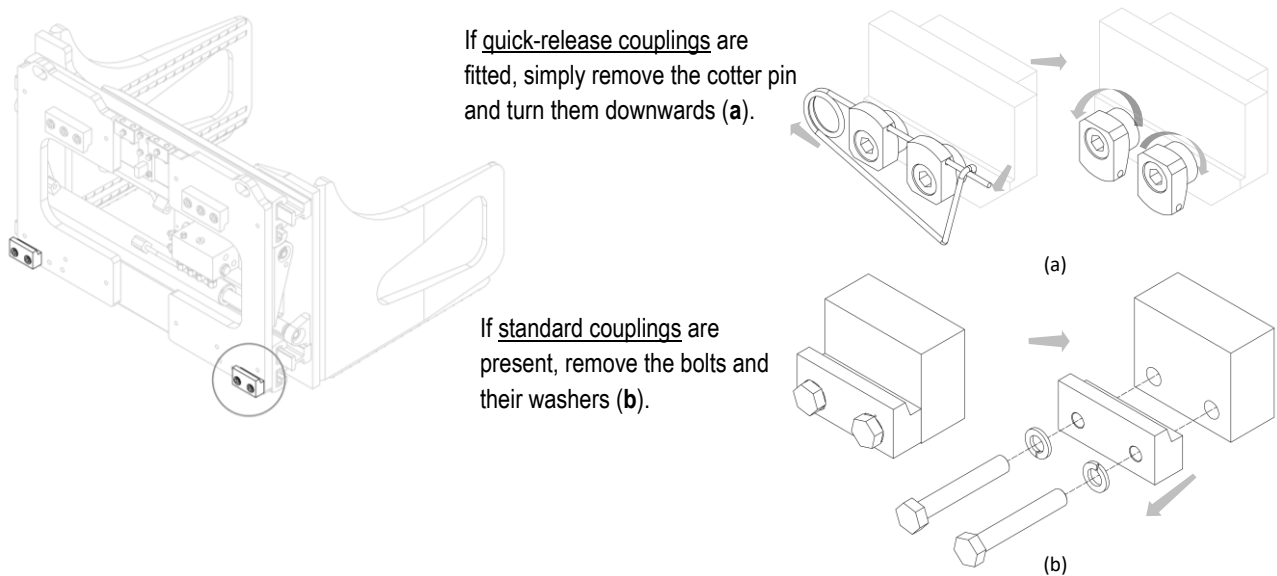

Figure 2

5. For handling, use straps or chains that are suitably sized in relation to the weight of the equipment as indicated on the plate (see *Figure 1* and *Table 1* on page 7).

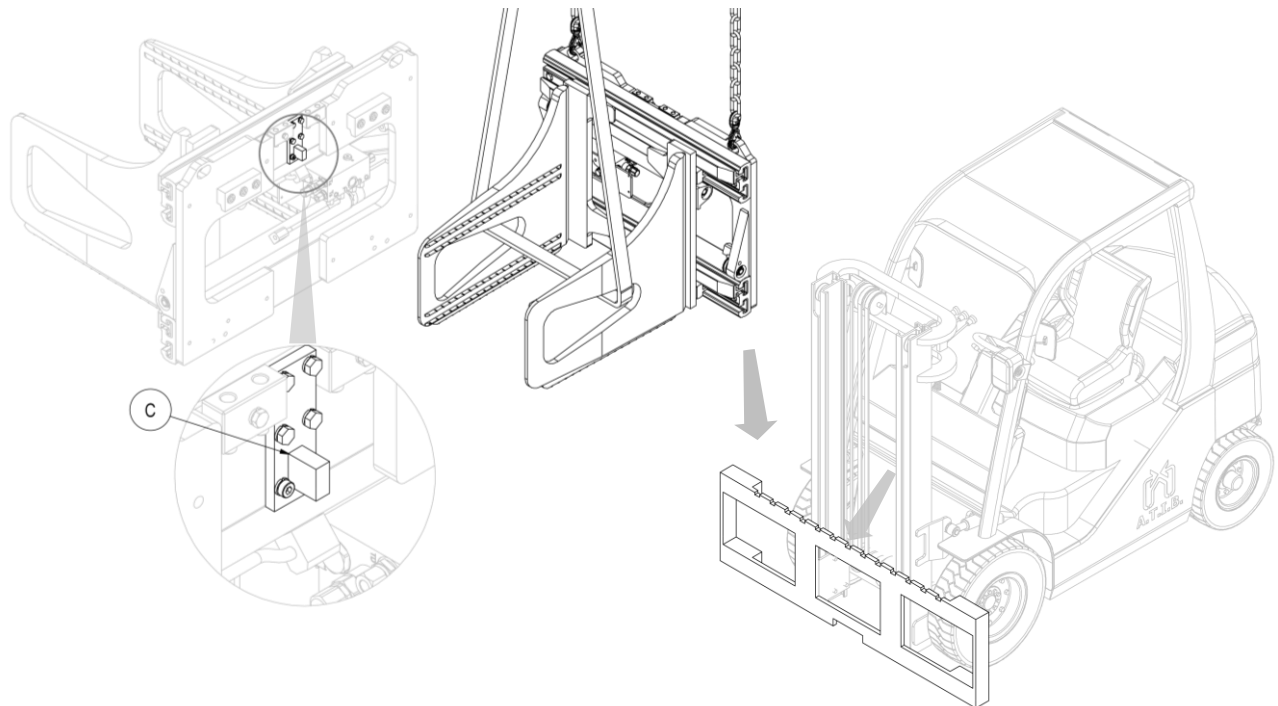

Figure 3

6. Then hook on the equipment using an overhead crane or hoist of sufficient capacity and position it on the fork carriage, taking care to fit centring pin C into the central notch on the fork carriage (see *Figure 3*).

7. Screw on the 2 lower couplings G in such a way that their bodies also remains coupled to the lower part of the fork carriage P (with max. clearance of 1.5 mm, see detail *Figure 4*), tightening with the torque indicated in *Table 3*.

CLASS	THREAD	TIGHTENING TORQUE
ISO II	M12	90 Nm
ISO III	M14	140 Nm

Table 3

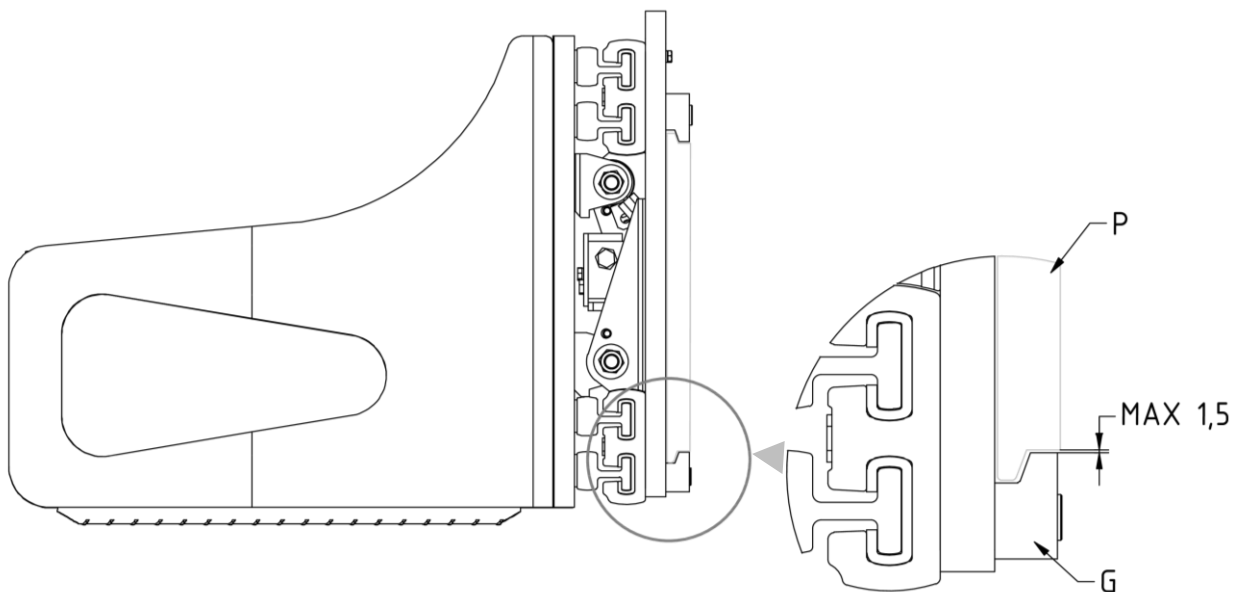

Figure 4

8. Lubricate contact surfaces.
9. Connect the hydraulic circuit, ensuring that the operating pressure of the lines is greater than or equal to that indicated on the rating plate (see *Figure 1* and *Table 1* on page 7).

### 3.1.2 Installing the Equipment - With Siss

#### WITH SISS

1. Prior to installation, check the condition of the fork carriage, ensuring that the lower profile is smooth which may otherwise affect the sliding of the lower pads.
2. In addition, ensure that the fork carriage profiles are not deformed in order to facilitate good coupling with the sideshift equipment.
3. Check the condition of the pipes, replacing those in a poor condition.

**N.B.** Although only type 474.131 is shown in the installation phase, the equipment installation procedure is identical for different versions (.130/.195, WITH SISS).

4. After removing the “protection bracket” (P) with its bolts, manually obtain the dual coupling A (with its sliding bushes), and position it on the upper profile of the fork carriage, taking care to fit the centring pin C into the central notch of the fork carriage (see *Figure 5*).

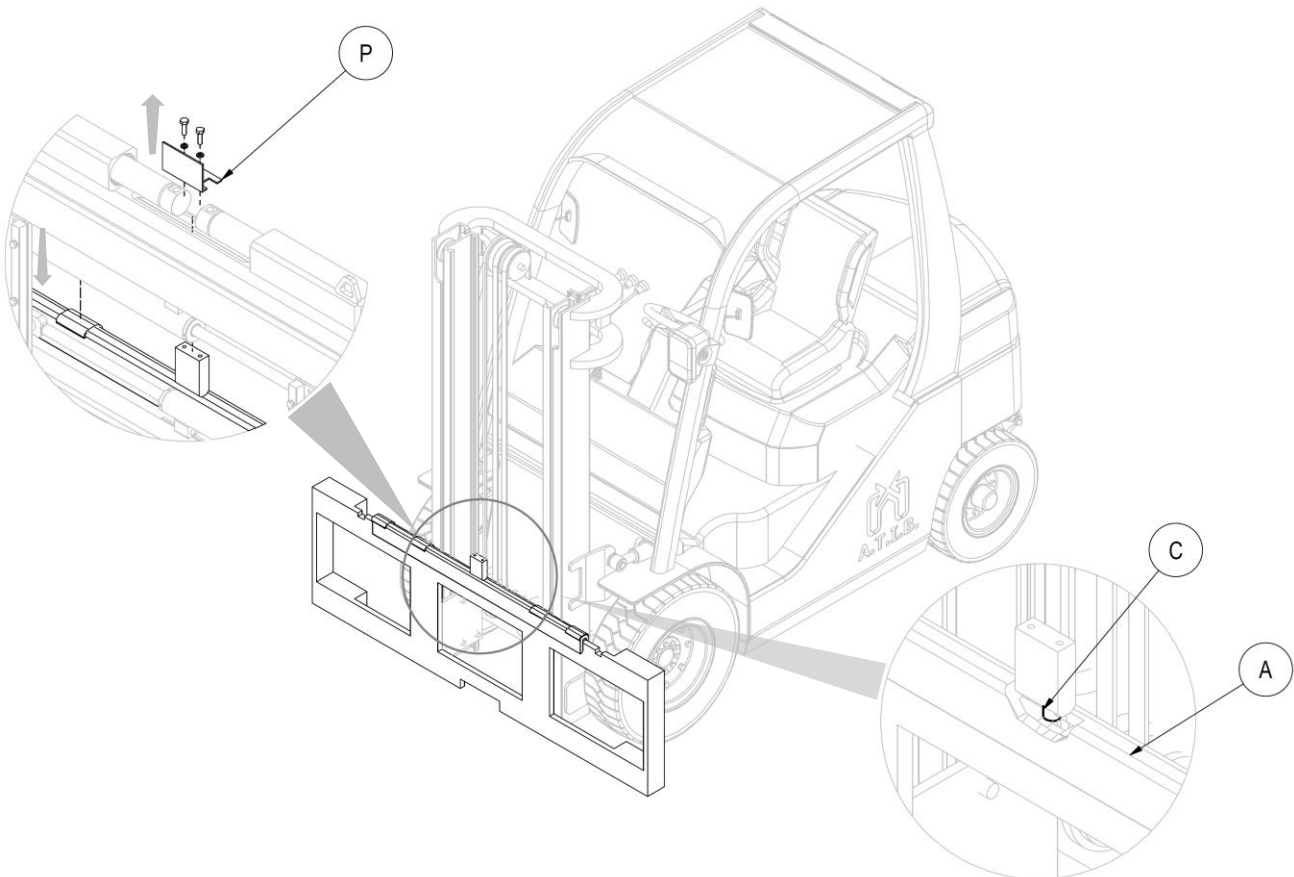

Figure 5

5. Remove the lower couplings from the equipment and grease the sliding gibs (see *Figure 6*).

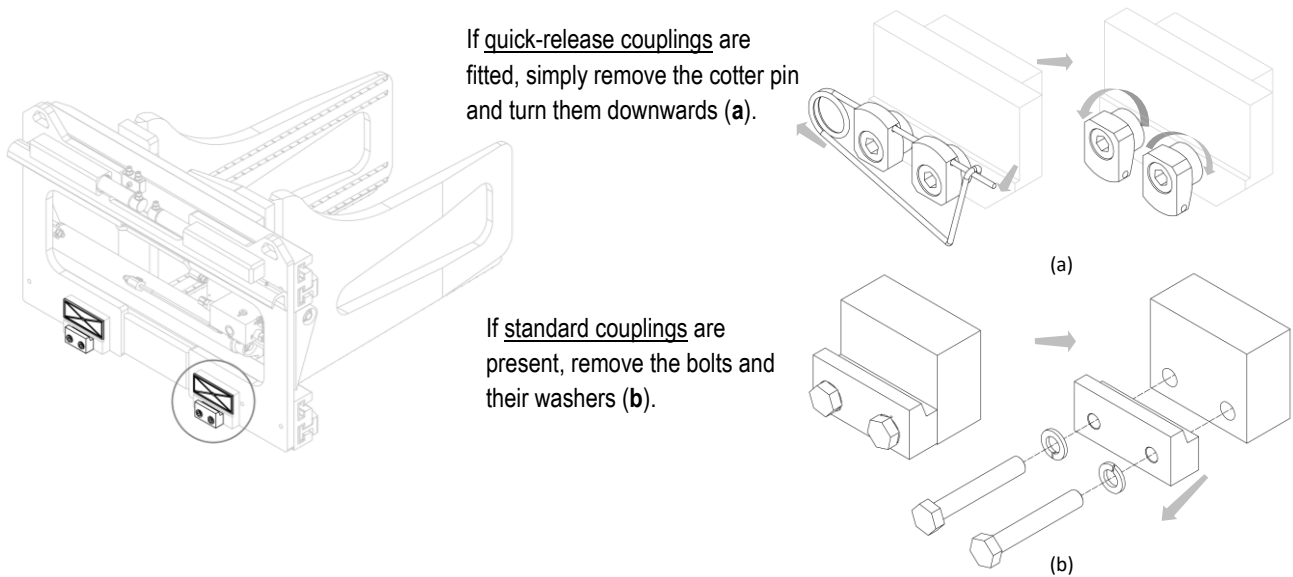

Figure 6

6. For handling, use straps or chains that are suitably sized in relation to the weight of the equipment as indicated on the plate (see *Figure 1* and *Table 1* on page 7).
7. Then hook on the equipment using an overhead crane or hoist of sufficient capacity and position it onto the dual coupling, taking care to position it correctly (see *Figure 7*).

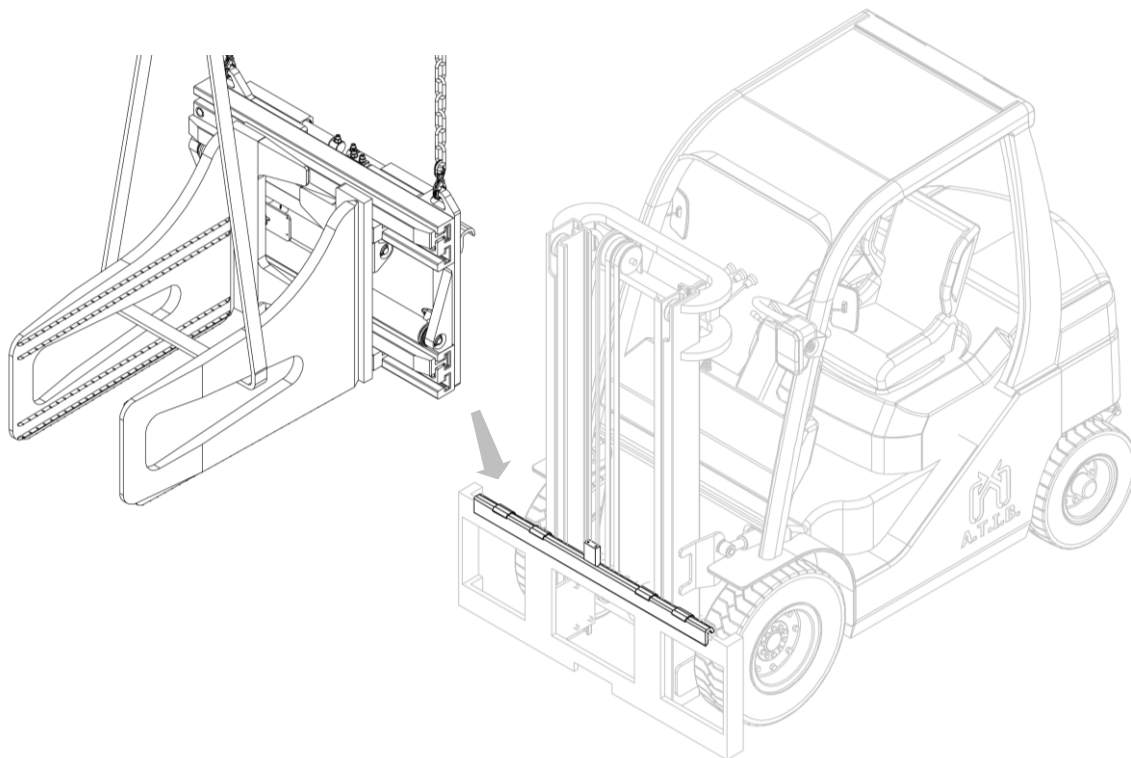

Figure 7



8. Reposition the “protection bracket”.
9. Screw on the 2 lower couplings G in such a way that their bodies also remains coupled to the lower part of the fork carriage P (with max. clearance of 1.5 mm, see detail *Figure 8*), tightening with the torque indicated in *Table 4*.

CLASS	THREAD	TIGHTENING TORQUE
ISO II	M12	90 Nm
ISO III	M14	140 Nm

Table 4

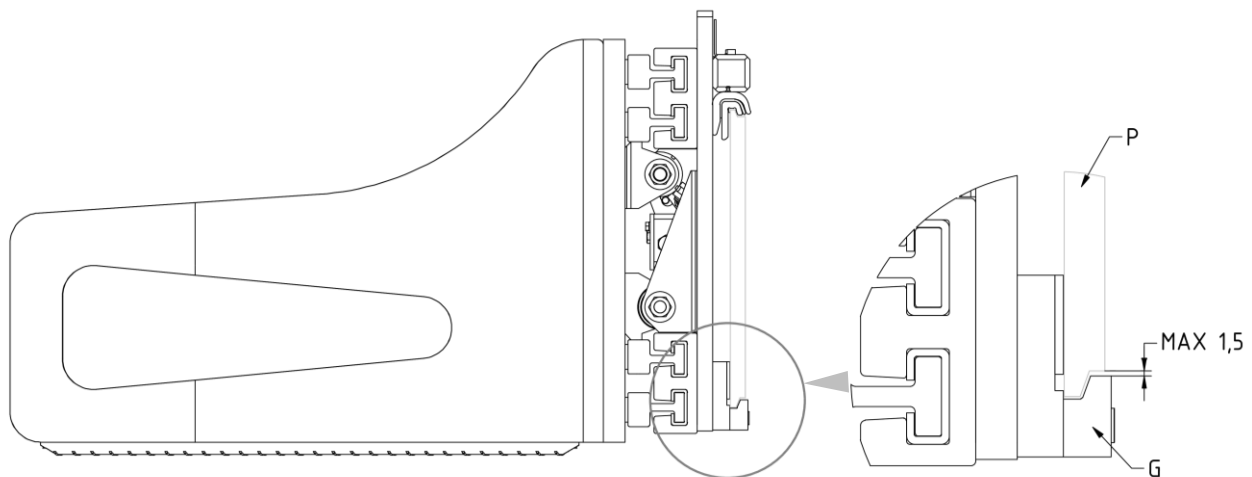

Figure 8

10. Lubricate contact surfaces.
11. Connect the hydraulic circuit, ensuring that the operating pressure of the lines is greater than or equal to that indicated on the rating plate (see *Figure 1* and *Table 1* on page 7).

## 3.2 Assembling the Aluminium Profiles

### ALUMINIUM

1. Release the pressure from the hydraulic system and disconnect the lines.
2. Install the aluminium profiles one at a time, using the bolts provided (see *Figure 9* and *Figure 10*).

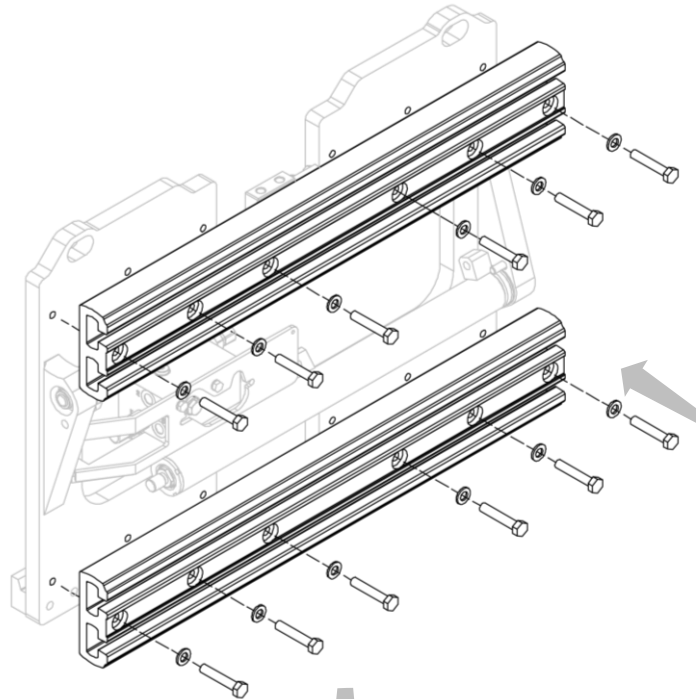

Figure 9

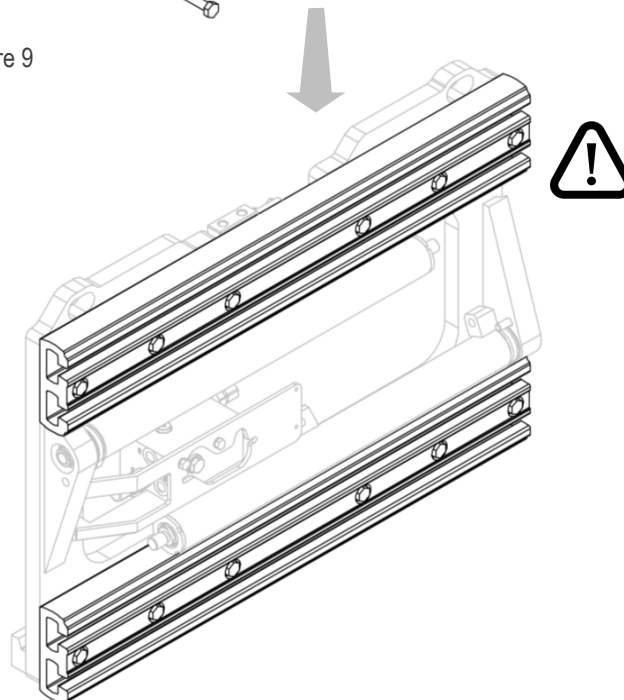

Figure 10

### 3.3 Assembling the Nylon Bushes

#### NYLON BUSHES

1. Release the pressure from the hydraulic system and disconnect the lines.
2. Insert the nylon bushes and secure them using the grub screws provided (see *Figure 11* and *Figure 12*).

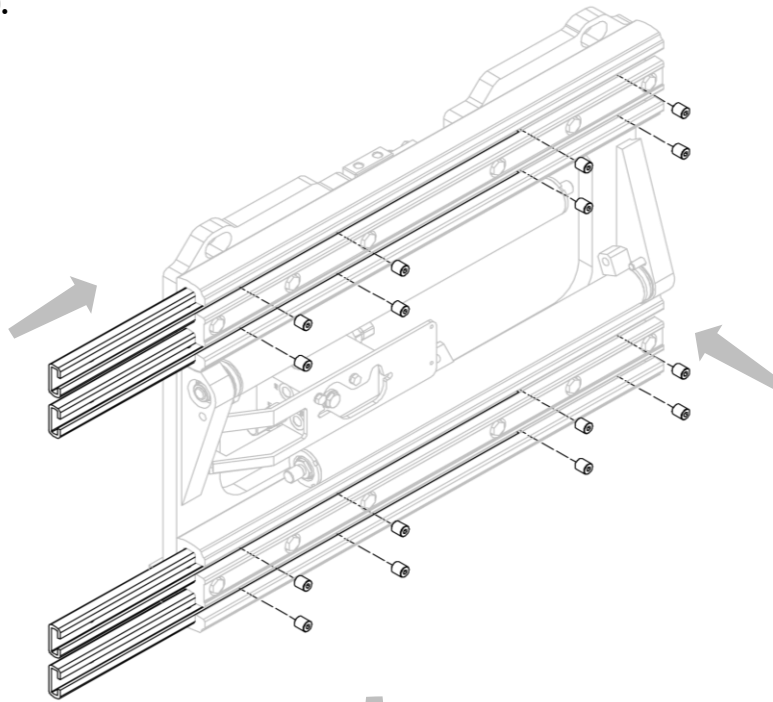

Figure 11

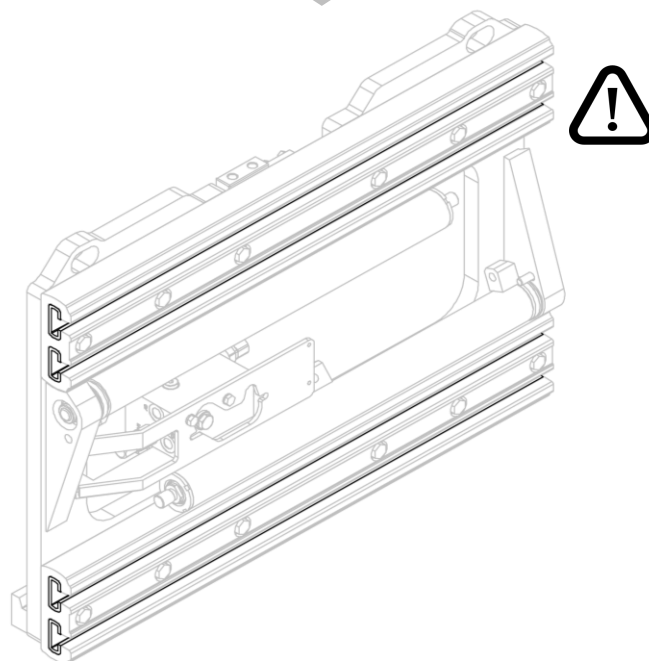

Figure 12

## 3.4 Assembling the Jaws

### 3.4.1 Assembling the Jaws onto the Equipment

**N.B.** Although only type 474.131 is shown, the procedure for installing the jaws on the equipment is identical for the other versions (.130/.195).

3. Release the pressure from the hydraulic system and disconnect the lines.
4. Insert the fork assembly + forks into their housings and secure them to the cylinders using the nuts (see *Figure 13* and *Figure 14*).

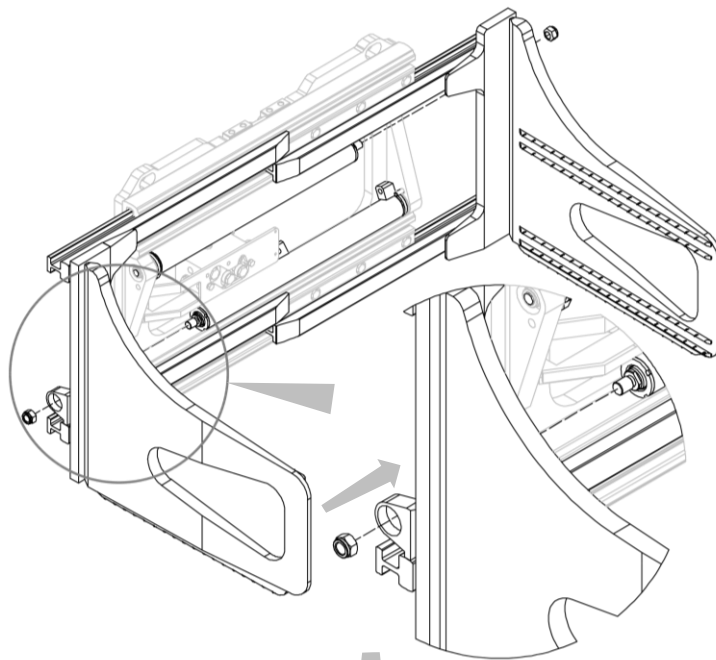

Figure 13

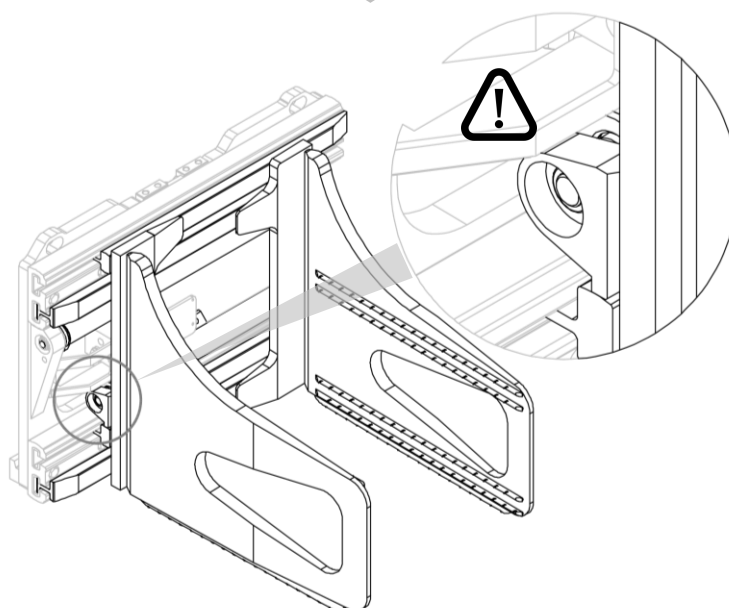

Figure 14

## 4 HYDRAULIC SYSTEM

**N.B.** Although only type 474.131 is shown in the images, the position of the solenoid valves is identical (.130/.195).

### 4.1 Hydraulic System - Valve B2383022

#### VALVE B2383022

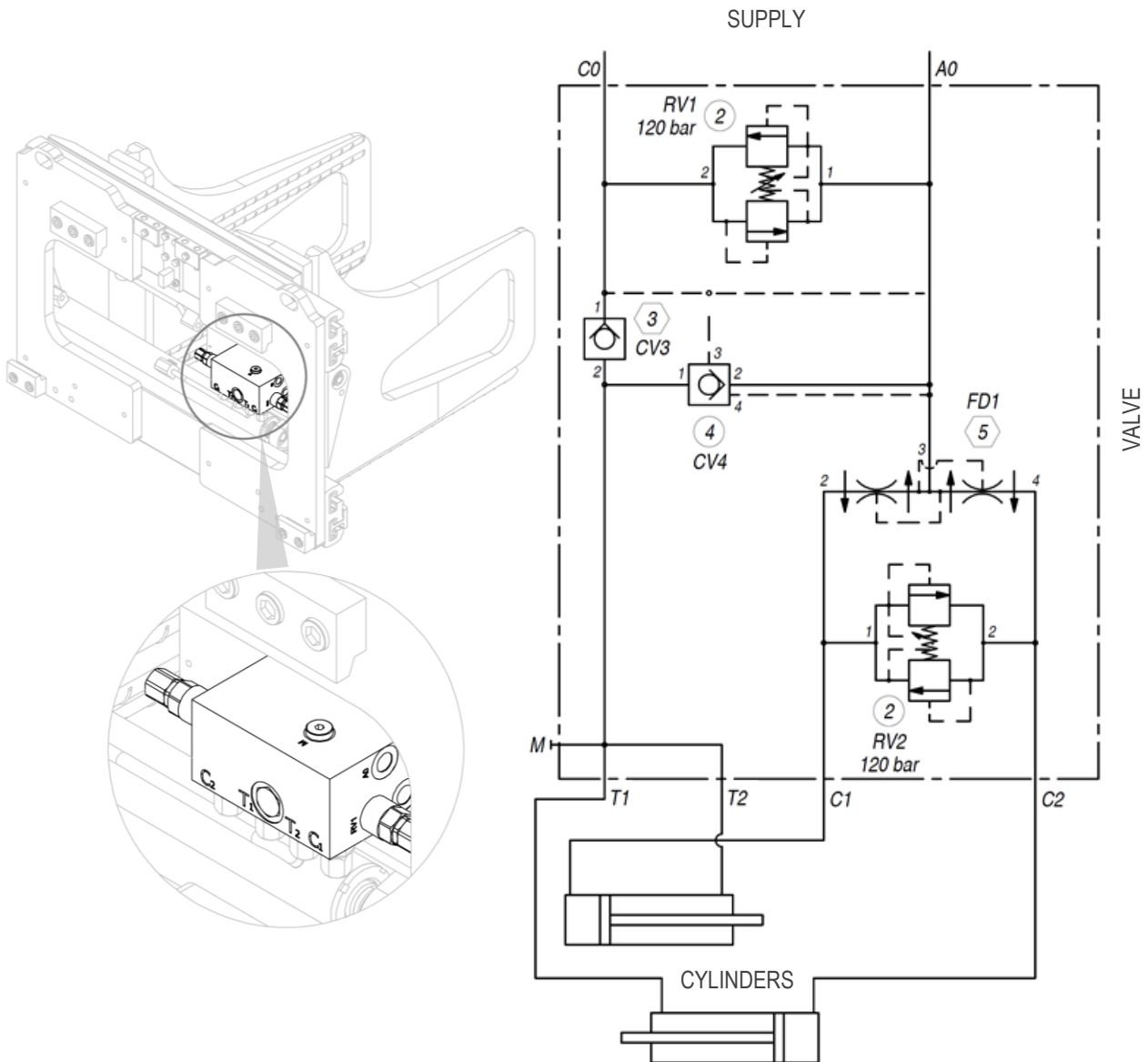

Figure 15

## 4.2 Hydraulic System - Valve B2383022 with Siss

### VALVE B2383022

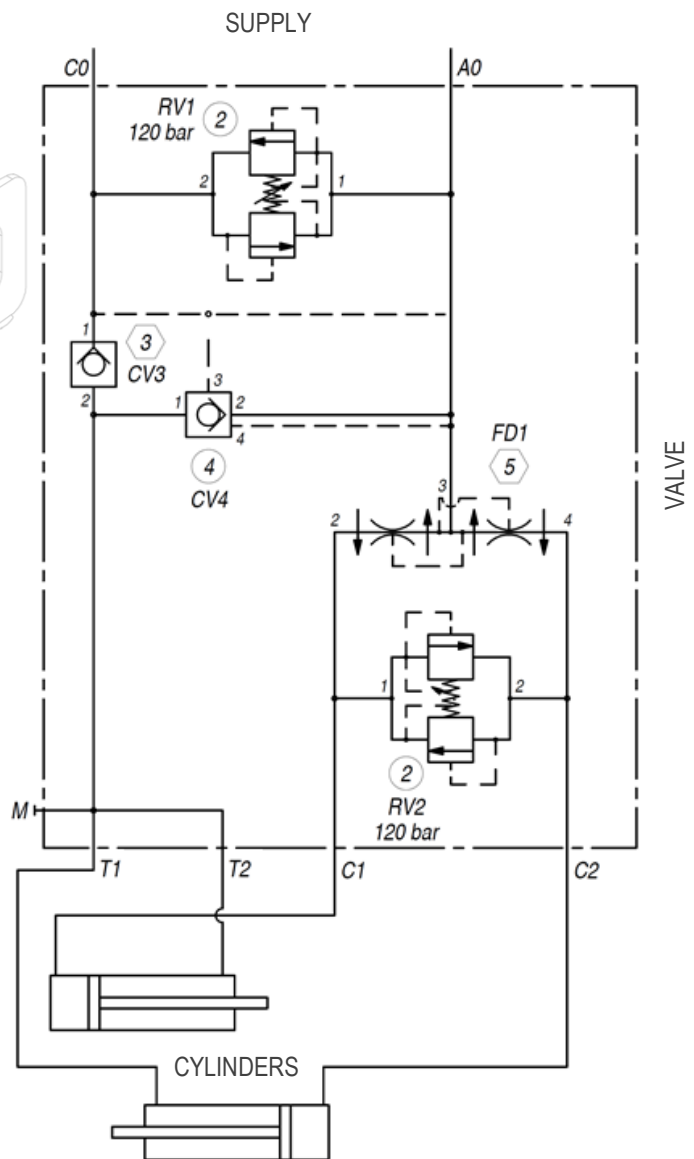
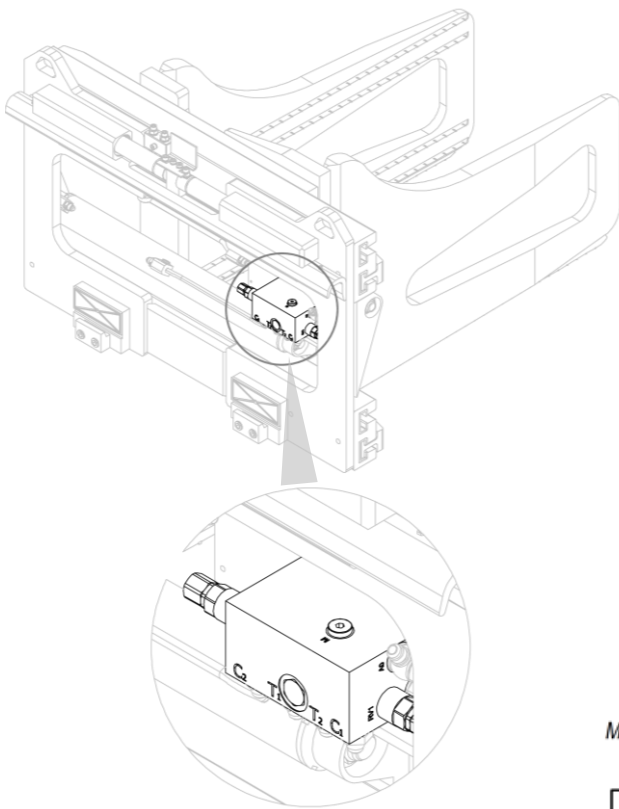
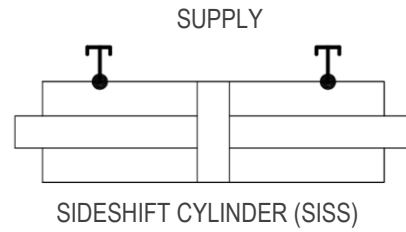

Figure 16

4.3 Hydraulic System – Iss – Valve B2383023

VALVE B2383023

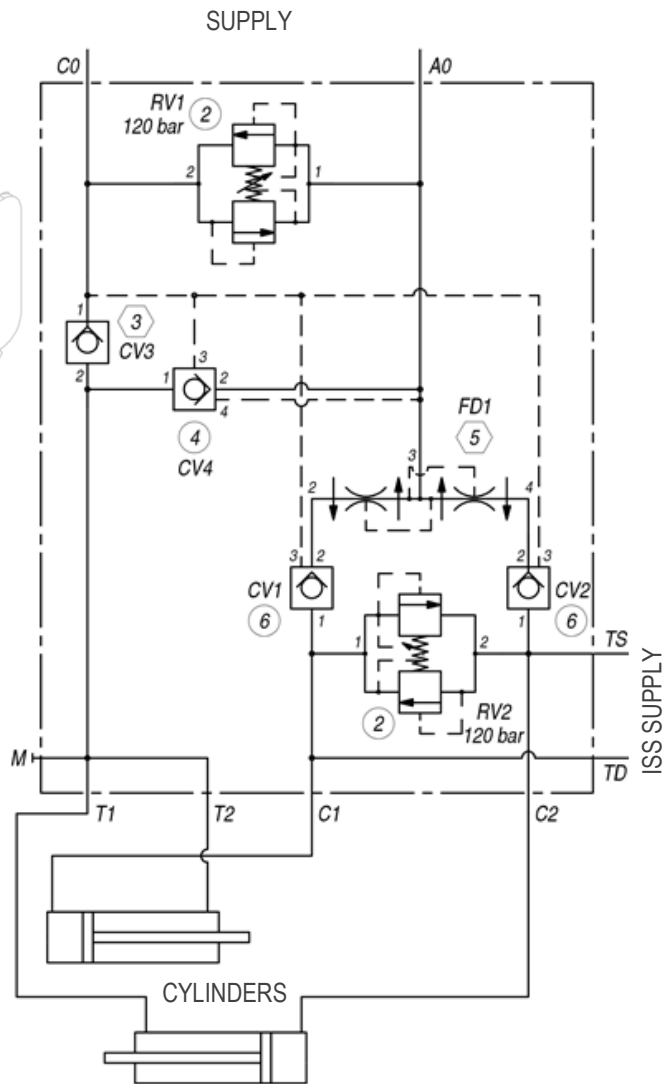
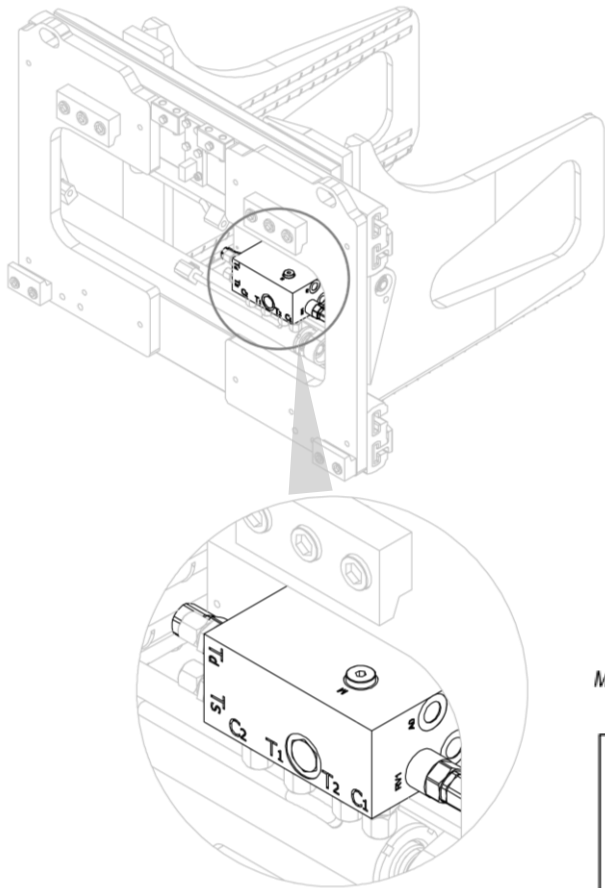

Figure 17

## 5 RULES GOVERNING USE

*Before using the equipment, check the tightness of the piping and the correctness of assembly and also the connection by performing a dozen preliminary operations.*

The following instructions must be followed when using the equipment:

1. Observe the capacity limits of the equipment.
2. Do not operate the equipment when persons or animals are within range of the forklift truck.
3. Do not attempt to move loads sideways by dragging them across the floor.
4. Do not exceed the maximum pressure indicated on the rating plate.
5. Operate the equipment from the forklift truck driver's seat using only a single operator.
6. Operate the sideshift control lever gently to avoid water hammer as far as possible.
7. All operations relating to installation, use and maintenance must be carried out by specialist personnel using suitable equipment for the type of work to be carried out.
8. Carry out maintenance and/or repairs with the forklift truck stationary and the hydraulic circuit inactive, using appropriate means of protection (gloves, safety shoes, etc.).
9. Only operate cylinder rods when they are correctly fitted on the equipment; The rods may otherwise be ejected at great speed by the elevated oil pressures.

The weighted sound pressure level is less than 70 dB (A).

If the equipment is subject to slight errors in the synchronisation of movement between the two jaws, operator intervention is required to nullify the displacement differences, which will increment over time.

The operator simply needs to hold one of the two jaws at the end of the opening or closing stroke for the time required for the other fork to recoup the accumulated difference in displacement.



All ATIB equipment is designed and manufactured according to a load positioned (with respect to its centre of gravity) at a certain distance from the vertical plane of the jaws.

If the distance of the centre of gravity from the vertical part of the jaws needs to be increased, the weight of the load must be reduced.

In this case, consult the chart shown in *Figure 18* where, as the distance from the centre of gravity increases (x-axis line), a multiplicative factor is included for load reduction purposes (y-axis line).

The multiplicative factor, obtained on the basis of the desired centre of gravity position, will be multiplied with the nominal capacity of the equipment. The product of this multiplication will be the actual transportable load.

The continuous line is to be considered for equipment declared with a 500mm centre of gravity load.

The dashed line is to be used for equipment declared with a 600mm centre of gravity load.

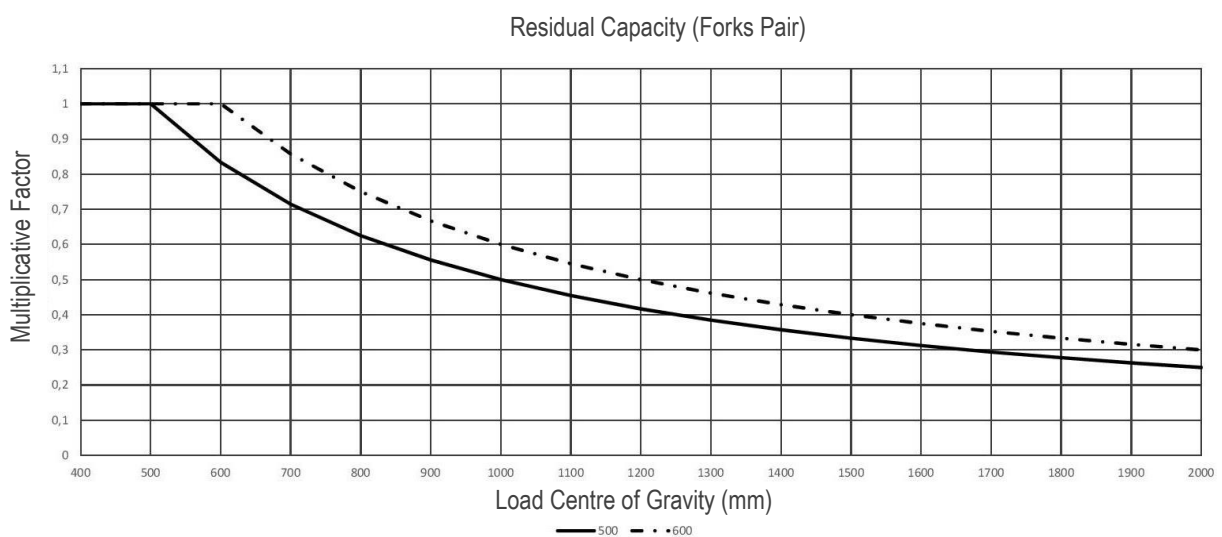

Figure 18

**NOTE: calculations are valid only for "stable" loads. Contact the manufacturer for transporting liquid containers.**



The attainable sideshift may compromise the stability of the forklift truck.



It is advisable to consult the manufacturer of the forklift truck to check the residual capacity of the forklift truck-equipment assembly.



The condition of the road surface, the speed at which the load is handled and the elevation may all affect the load's grip, which must be taken into account on a case-by-case basis.



Displacing the load whilst in motion is prohibited.  
Handling the load with the mast raised off the ground is only permitted when returning the load to the centre of the mast.

The nominal capacity of the forklift truck/equipment combination is established by the original manufacturer of the forklift truck and may be less than that indicated on the equipment plate.

Consult forklift truck plate (Directive 2006/42/EC).

## 5.1 Integral Sideshift

This is the one most frequently used in “BALE CLAMP WITH THIN BLADES TYPE 474.131 | BALE CLAMP WITH CRIMPED BLADES TYPE 474.130 | CLAMP FOR FOAM RUBBER BLOCKS TYPE 474.195” and uses the same cylinders that carry out the clamping. The stroke depends on the opening and will be equal to zero in maximum opening and minimum closing. Since the stroke of the equipment may be higher than that defined by the stability regulations of forklift trucks (100 + 100 mm up to 6300 kg capacity and 150 +150 mm for higher capacities) and can, therefore, generate issues regarding lateral stability and premature wear of the upright profiles, it will be necessary to check feasibility with the forklift truck manufacturer.

Sideshift with a given load will be the minimum between the following two values:

1. Maximum opening (A max) less load width (Lc) divided by two.  $[(A \text{ max} - Lc) / 2]$
2. Load width (Lc) less minimum opening (A min) divided by two.  $[(Lc - A \text{ min}) / 2]$

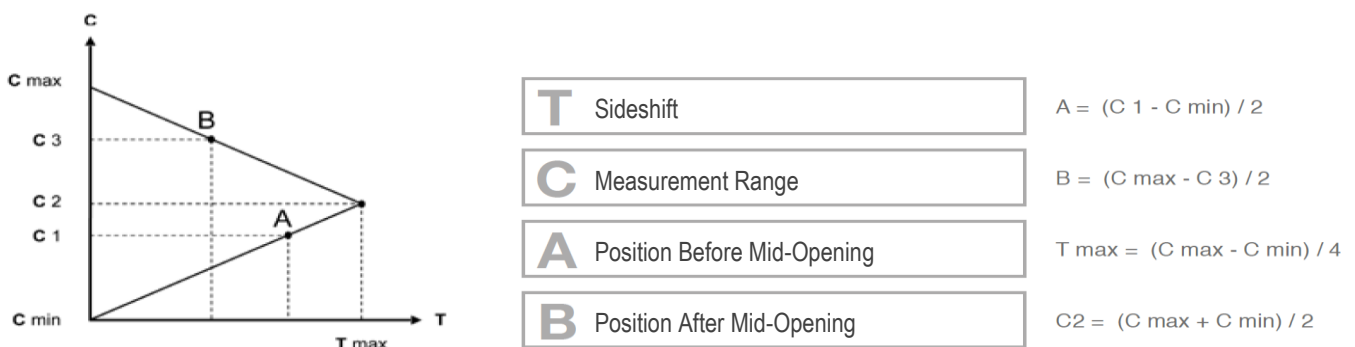

Figure 19



Off-centre sideshift of the load is only permitted on the ground. In this case, a loss of clamping force may occur, which may result in load loss. As a precaution, the centre of gravity of the equipment can be assumed to move laterally by the value of the sideshift (per side). If the precise value is required, consult the manufacturer of the equipment.

## 5.2 Handling Loads

The minimum transportable dimensions must be greater than the minimum grip. Depending on the load to be transported, this difference may vary and must be evaluated on a case by case basis by the operator.



*Avoid handling and/or sideshift of the forklift truck/equipment with a load that is excessively high off the ground, as this may affect its stability.*



*Avoid displacing/handling unstable loads.*



*Avoid displacing/handling loads with an uncentred centre of gravity.*

## 6 PERIODIC MAINTENANCE

Failure to comply with the rules and intervals established for maintenance will compromise the correct operation of the equipment and will void the conditions of the warranty.

***All maintenance operations must be carried out with the forklift truck stationary and the hydraulic circuit disconnected and depressurised. The entire maintenance area must be barricaded using regulation protection devices and, if the cylinders require disassembly, a tray or container must be provided to catch the oil present in the cylinder.***

To prevent issues when using the equipment, A.T.I.B. recommends changing the hydraulic oil and filters regularly and keeping the system as clean as possible during maintenance operations.

### ATTENTION!!!

Hydraulic parts may be very hot. Use suitable protective equipment.

Watch out for leakage. High-pressure oil can injure eyes and skin. Wear protective eyewear that includes side shields.

Do not remove valves, lines or other potentially pressurised parts when this is active.

### 6.1 Maintenance Every 100 Hours

1. Check the condition of the hydraulic connections (lines and fittings), replacing worn parts if necessary.
2. Check tightening torque of the bolts of the lower retaining couplings of the equipment, ensuring that it is as indicated in *Table 3* (page 13) and in *Table 4* (page 16) and, if necessary, adjust the bolts holding them in place.
3. Check clearance between the lower part of the fork carriage and the lower equipment couplings, ensuring that it is as shown in *Figure 4* (page 13) and in *Figure 8* (page 16) and, if necessary, adjust the bolts holding them in place.
4. Clean and lubricate all sliding parts (see *Figure 31* on page 40 and *Figure 24* and *Figure 25* on page 41).

### 6.2 Maintenance Every 300 Hours

1. Check condition of bushes and sliding gibs. If excessively worn component are detected, replace the entire component assembly in question.
2. Carry out the additional operations listed in the previous point (*Point 6.1*).

### 6.3 Maintenance Every 1000 Hours

1. Check condition of bushes and sliding gibs. If excessively worn component are detected, replace the entire component assembly in question.
2. Carry out the additional operations listed in the previous points (Point 6.1 and 6.2 on page 28).

### 6.4 Maintenance Every 2000 Hours

1. Carry out a thorough inspection of the equipment. If possible, this should be carried out by qualified personnel who are able to identify any issues that may compromise the safety and efficiency of the equipment. There may be a number of defects, such as the following:
  - Check condition of all equipment components (cylinders, couplings, seals, fittings, grease nipples, etc.) to ensure that they are in good condition and replace any worn parts.
  - Check condition of sliding and working surfaces and replace if damaged.

For further potential issues (and their solutions), refer additionally to *Table 5* on page 39.

2. Disassemble cylinders and check condition of piston rods and seals. If a damaged or excessively worn seal is detected, it is always advisable to replace the entire seal assembly.
3. Replace seals in the event of oil leakage and replace rods if they are scratched (cylinders should always be tested when inserted into the equipment to prevent sudden ejection of rods).
4. Carry out the additional operations listed in the previous points (*Point 6.1*, and points 6.2 on page 28 and 6.3).

**N.B. Reduce intervals in the event of use under particularly harsh conditions**

## 7 DISASSEMBLY PROCEDURE

All maintenance operations must be carried out with the forklift truck stationary and the hydraulic circuit disconnected and depressurised. The entire maintenance area must be barricaded using regulation protection devices and, if the cylinders require disassembly, a tray or container must be provided to catch the oil present in the cylinder.

### 7.1 Removing the Equipment from the Forklift Truck

1. Release the pressure from the hydraulic system.
2. If the equipment is WITH SISS, remove the protection bracket on the dual coupling, as shown in *Figure 5* on page 14.
3. Remove the lower couplings from the assembly (see *Figure 2* and *Figure 6* on page 11 and 15).
4. For handling, use straps/chains that are suitably sized in relation to the weight of the equipment as indicated on the plate.
5. Then lift the equipment using the upper attachment points using an overhead crane or hoist of sufficient capacity and remove it from the forklift truck (see *Figure 3* and *Figure 7* on page 12 and 15).

## 7.2 Disassembling the jaws

### 7.2.1 Removing the Jaws from the Equipment

**N.B.** Although only type 474.131 is shown, the procedure for removing the jaws from the equipment is identical for the different versions (.130/.195).

1. Release the pressure from the hydraulic system and disconnect the lines.
2. Remove the fork assembly with the jaws after unscrewing the nuts securing them to the cylinders (see *Figure 20* and *Figure 21*).

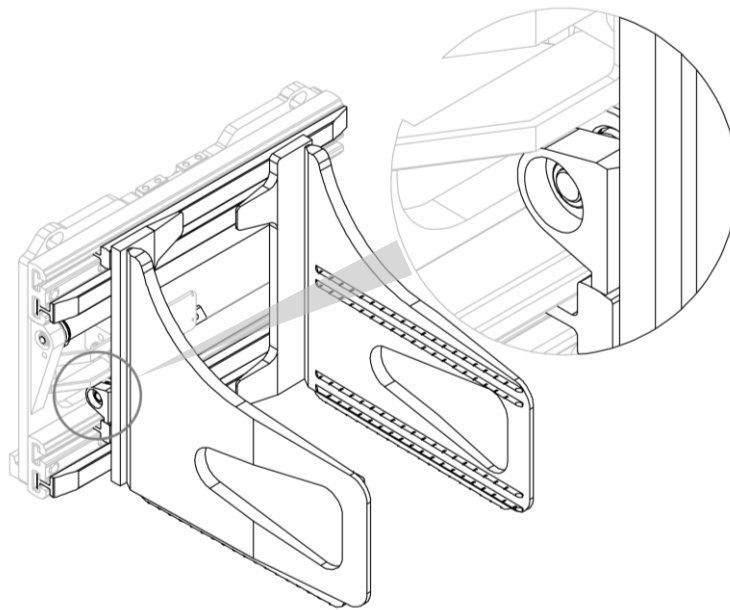

Figure 20

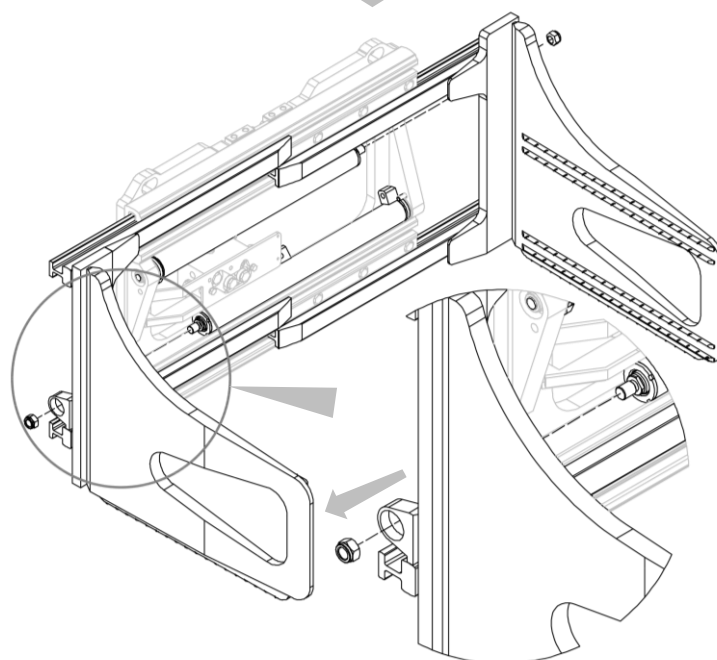

Figure 21



## 7.3 Disassembling the Nylon Bushes

### NYLON BUSHES

1. Remove the fork assembly from the equipment.
2. Release the pressure from the hydraulic system and disconnect the lines.
3. Remove the nylon bushes after unscrewing the corresponding grub screws (see *Figure 22* and *Figure 23*).

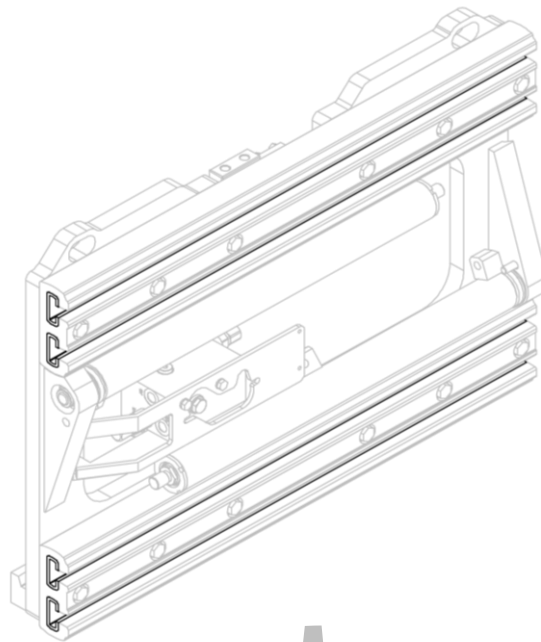

Figure 22

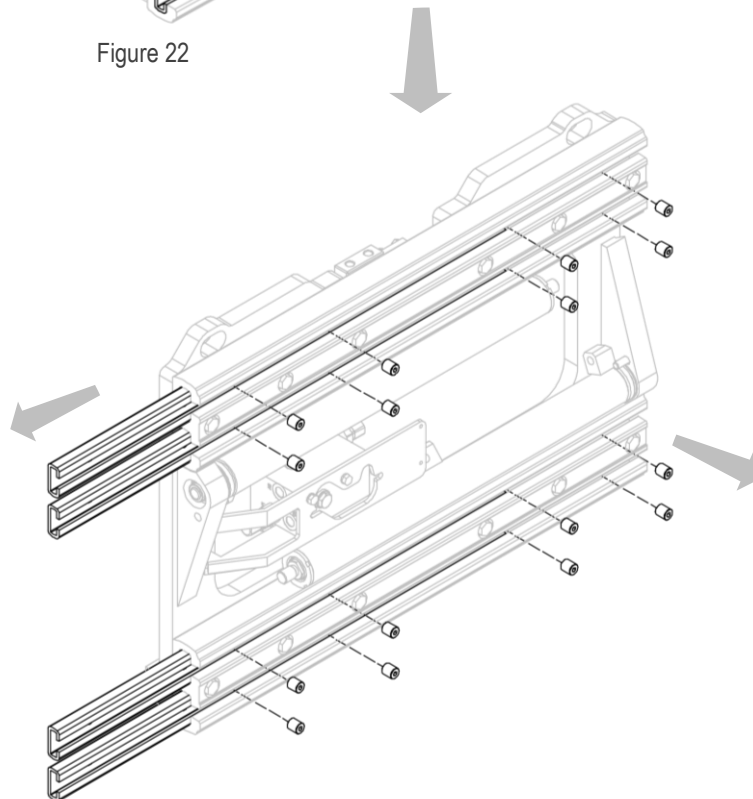

Figure 23

## 7.4 Disassembling the Aluminium Profiles

### ALUMINIUM

1. Release the pressure from the hydraulic system and disconnect the lines.
2. Remove the aluminium profiles, one at a time, after unscrewing the bolts (see *Figure 24* and *Figure 25*).

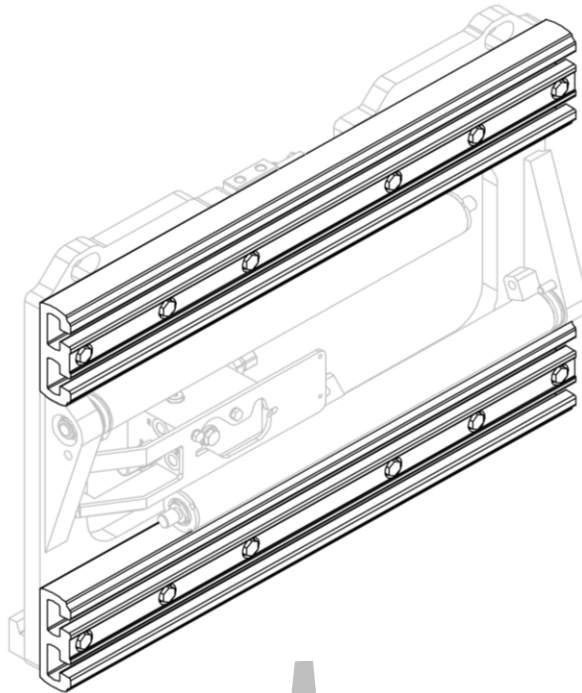

Figure 24

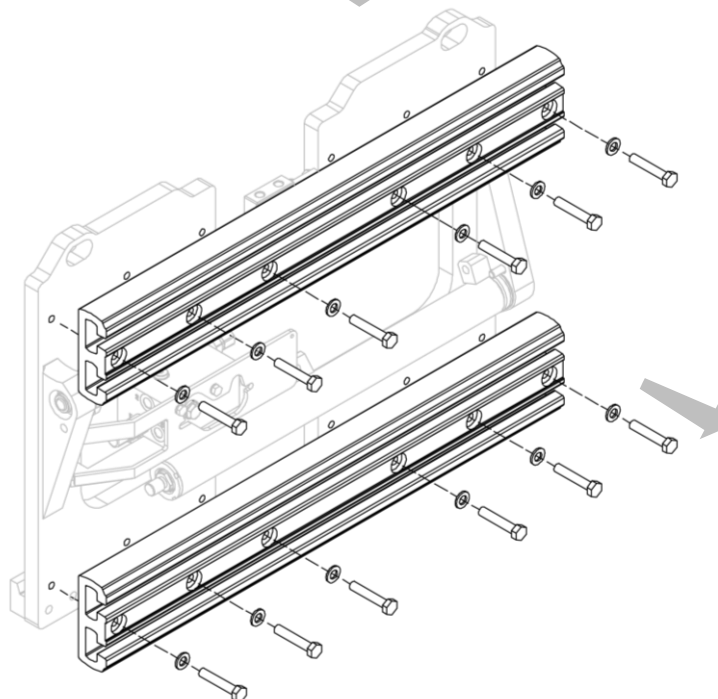

Figure 25

## 7.5 Removing the Clamping Cylinders from the Equipment

**N.B.** Although only type 474.131 with siss is shown, the procedure for removing and disassembling the clamping cylinders is identical for the other versions (.130/.195).

### JAW CYLINDERS

1. Open the cylinders.
2. Release the pressure from the hydraulic system and disconnect the lines.
3. Remove the nuts D that secure the cylinders to the forks (see *Figure 26*).

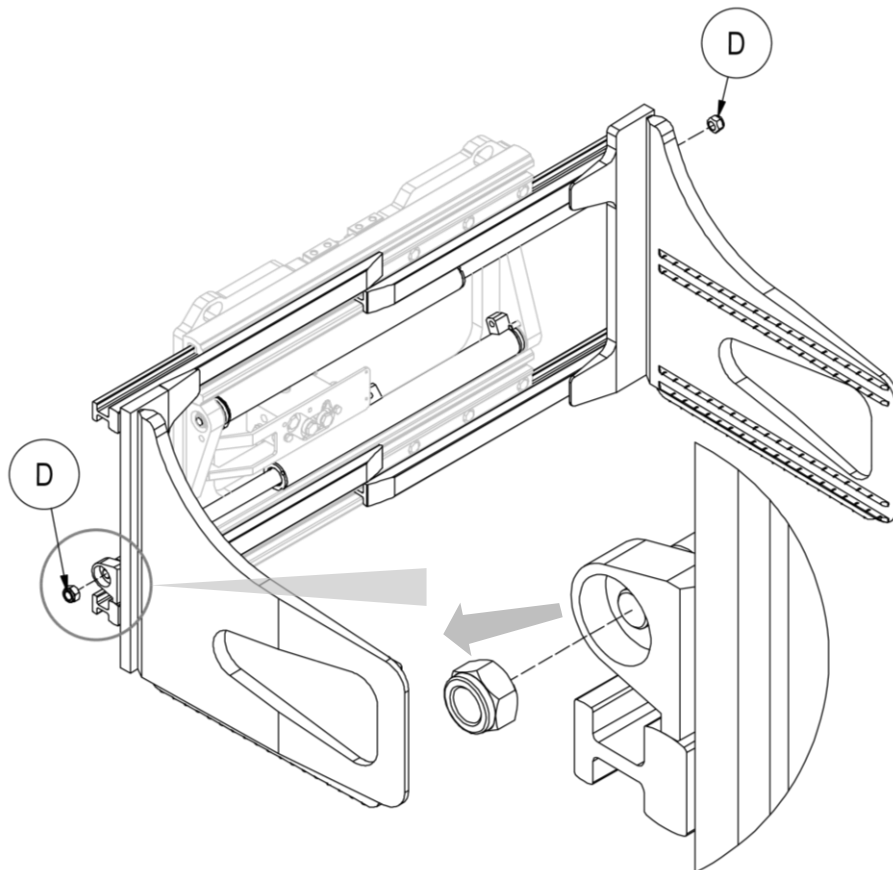

Figure 26

4. Reconnect the hydraulic system.
5. Close the cylinders.

6. Release the pressure from the hydraulic system and disconnect the lines.
7. Remove the nuts D that secure the cylinders to the equipment assembly and remove the cylinders, taking care not to damage them (see *Figure 27*).

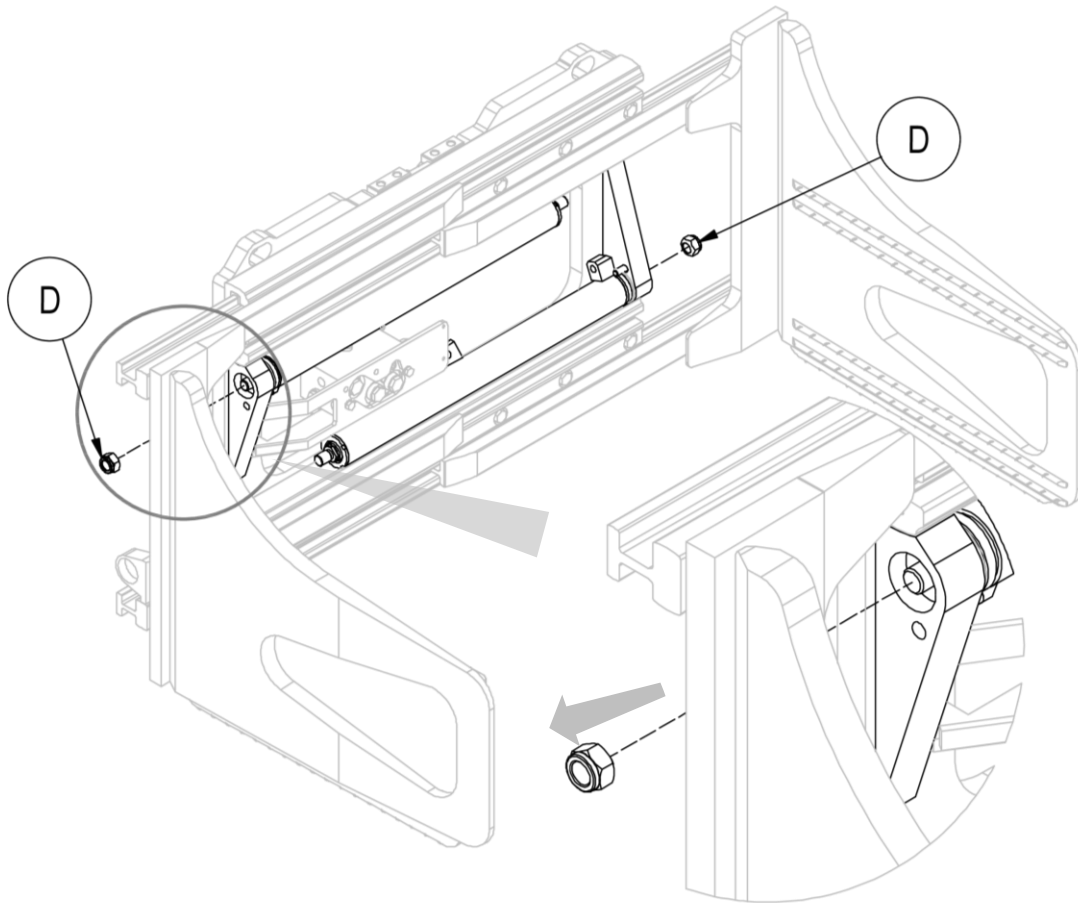

Figure 27

### 7.5.1 Disassembling and Reassembling the Clamping Cylinders

If the entire cylinder needs to be replaced, reassemble following the instructions listed in the previous point. If any cylinder components need to be replaced, proceed as indicated below:

1. Clamp the cylinder body in a vice using soft jaws (taking care not to deform the liner).
2. Use a C-hook spanner to remove cap T.
3. If the cap will not unscrew, slightly heat the area of the thread in question to facilitate unscrewing.
4. Unscrew rod C.
5. Disassemble/separate the rest of the components and seals (this will be easy and rather intuitive at this stage).
6. Replace damaged parts and reassemble by repeating the above steps in reverse order, taking care to relock the cylinder cap using medium strength threadlocker.
7. If a damaged seal is found, it is advisable to replace the entire seal assembly.
8. Use *Figure 28* as a guide.

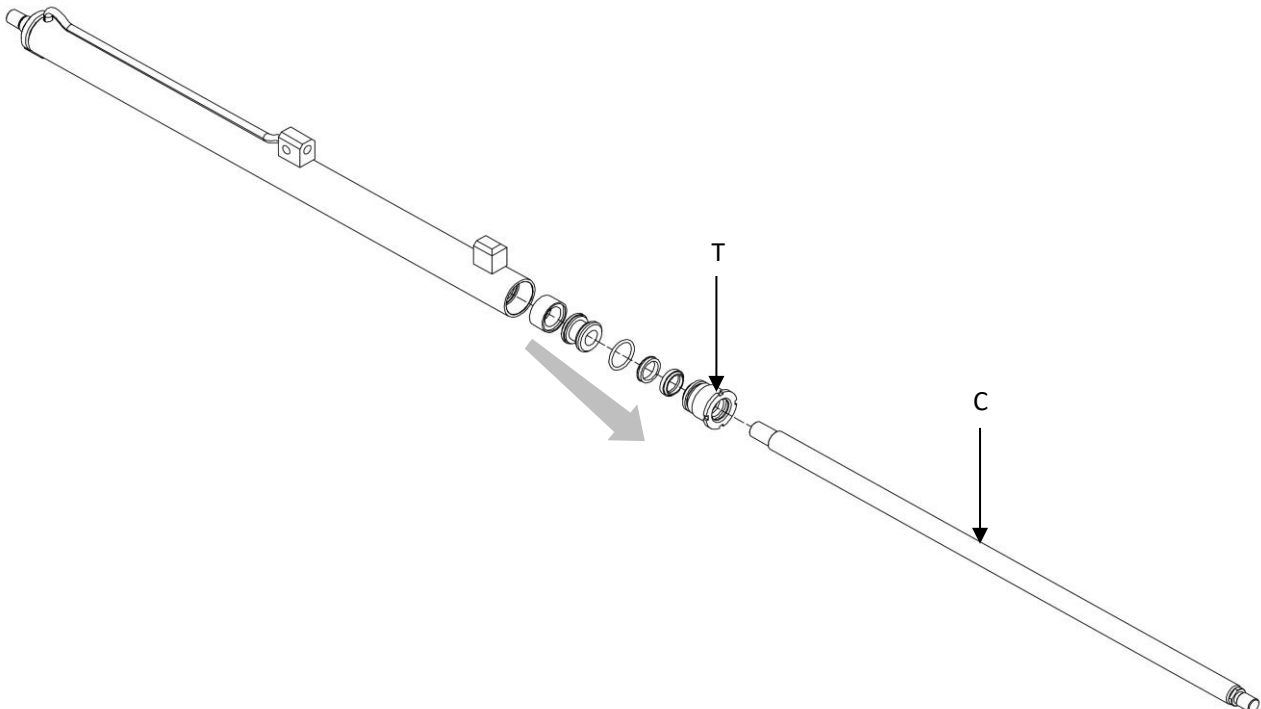

Figure 28

## 7.6 Sideshift Cylinder Maintenance (siss)

### CYLINDERS SISS

1. Release the pressure from the hydraulic system and disconnect the lines.
2. Remove the equipment from the forklift truck, as outlined in point *Removing the Equipment from* the Forklift Truck on page 30.
3. Remove dual coupling (A) after removing the “protection bracket” (P) with its associated bolts, (in *Removing the Equipment from* the Forklift Truck this step has already been outlined).
4. Extract the rods one at a time and remove the seals from their housings (after removing the snap ring that holds them in place).
5. Replace damaged parts and reassemble by repeating the above steps in reverse order.
6. If a damaged seal is found, it is advisable to replace the entire seal assembly.
7. Use *Figure 29* and *Figure 30* as guides.

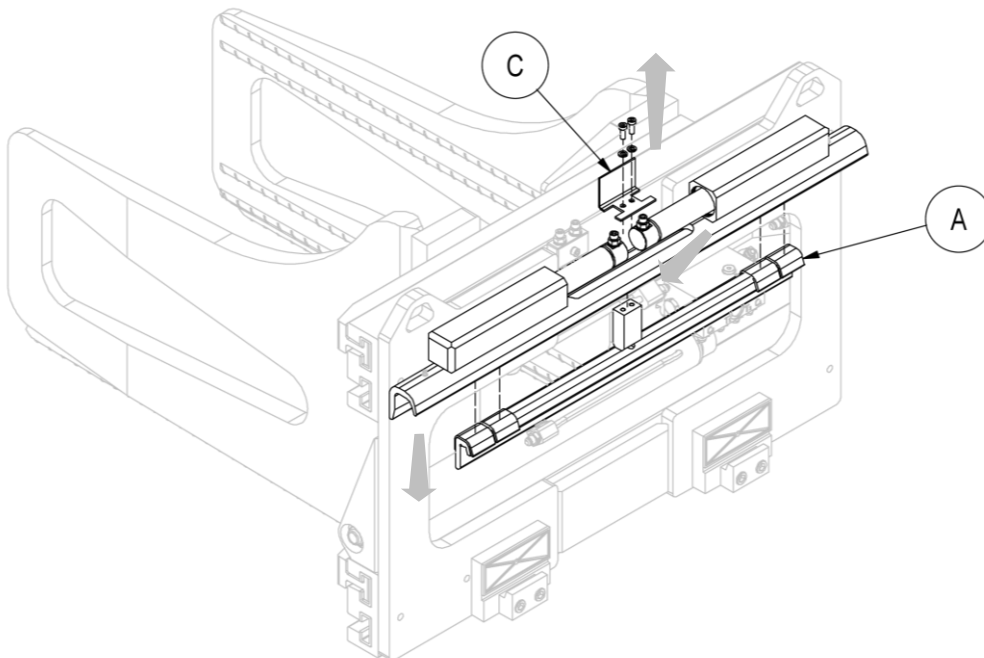

Figure 29

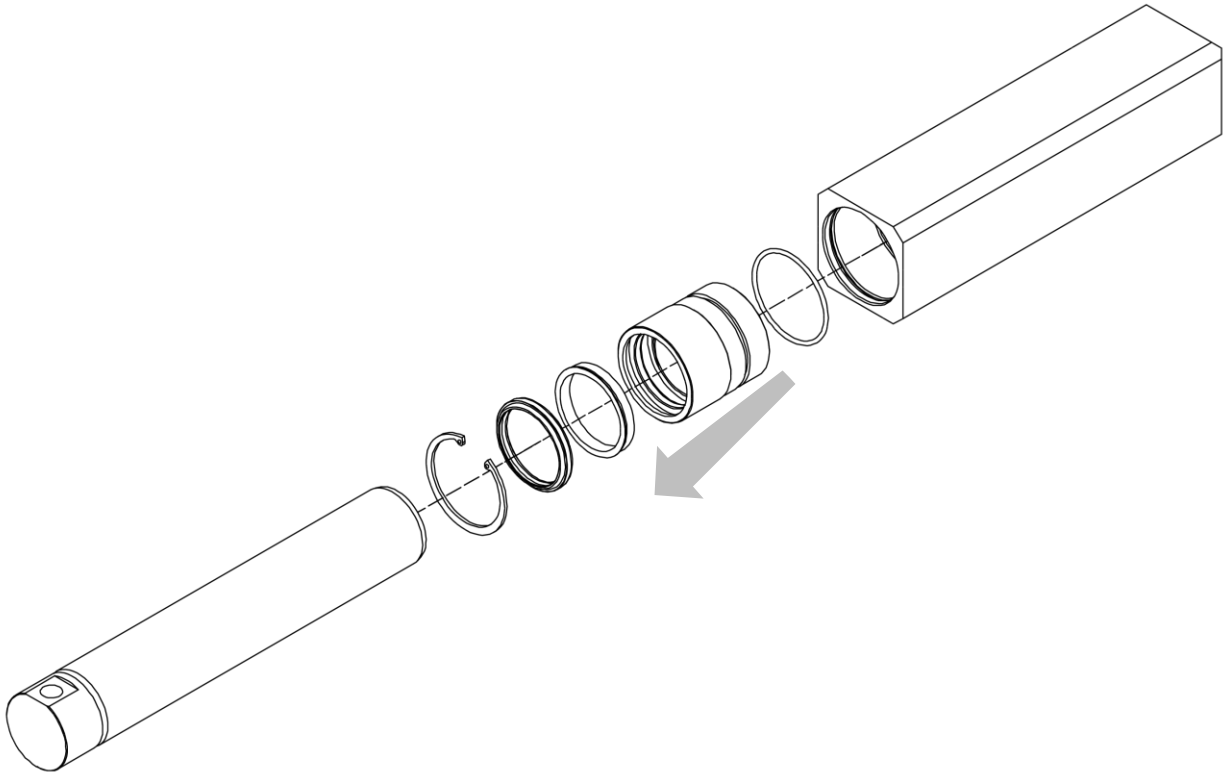

Figure 30

**N.B.** Although only type 474.131 with sis is shown, the procedure for removing and disassembling the sashift cylinders is identical for the other versions (.130/.195, also WITH SISS).

## 8 TROUBLESHOOTING

### 8.1 Probable Faults and Solutions

FAULT	CAUSE	SOLUTION
Insufficient force	Calibration of the maximum pressure valve too low	Increase the pressure without exceeding the maximum limit
	Insufficient pressure	Contact the forklift truck manufacturer
	Worn pump	Replace it
	Worn cylinder seals	Replace them
	No oil in the tank	Fill up
Pressure drop	Oil leakage through pipes and fittings	Tighten the fittings or replace them
	Oil leakage from the cylinders	Replace the seals or, if necessary, the cylinders
	Load loss in sideshift	Lower sideshift pressure
	Load loss	Check jaw camber angle
Slow opening and closing	Low oil flow rate	Check the tank level and/or the pump Constrictions in the system: search for them and remove them
	Insufficient pressure	Adjust the calibration of the maximum pressure valve
	Mechanical deformations of some parts	Repair or replace
	Worn cylinder seals	Replace them
	No oil in the tank	Fill up
	Air in hydraulic system	Purge system
Erratic displacement	Worn gibs or sliding rollers	Replace
	Excessive friction between sliding parts	Clean and grease sliding parts
	Worn cylinder seals	Replace them
	No oil in the tank	Fill up

Table 5

**For further issues, contact A.T.I.B. S.r.l.**



## 8.2 Lubrication

1. Lubricate sliding components using grease nipples.
2. Grease gibs and bars/sliding surfaces (e.g. nylon bushes).

**N.B.** Although only type 474.131 is shown, the lubrication procedure is identical for the other versions (.130/.195).

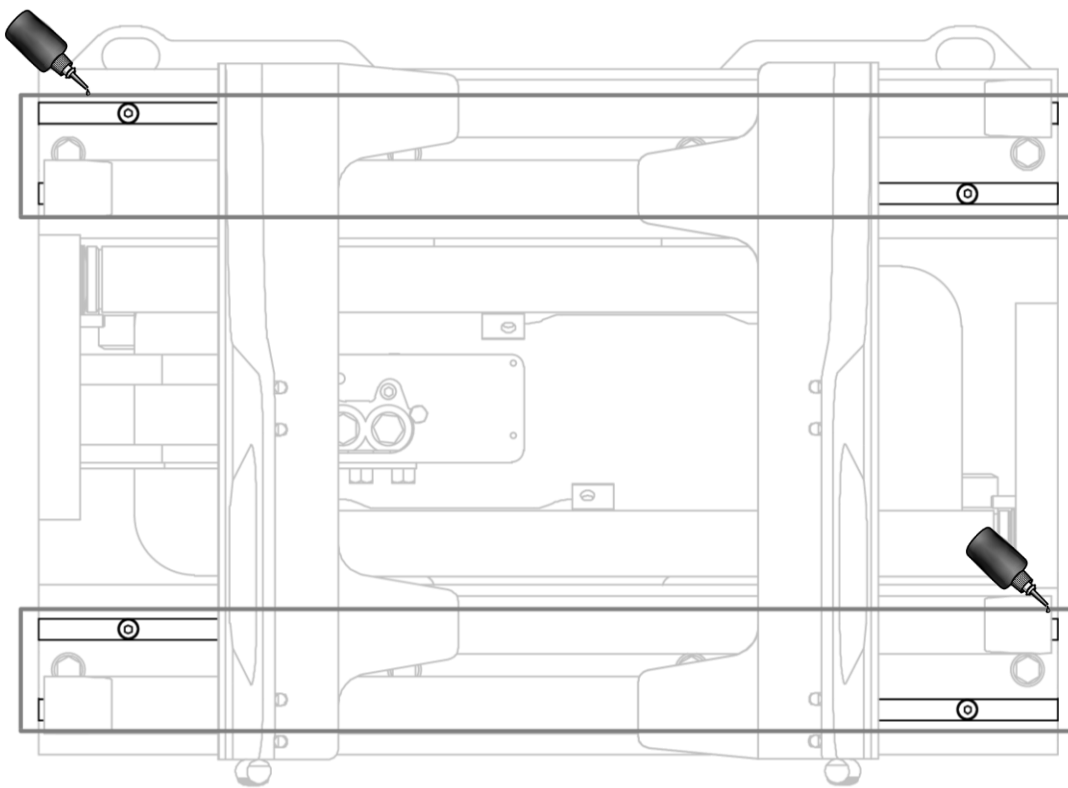

Figure 31

WITH SISS

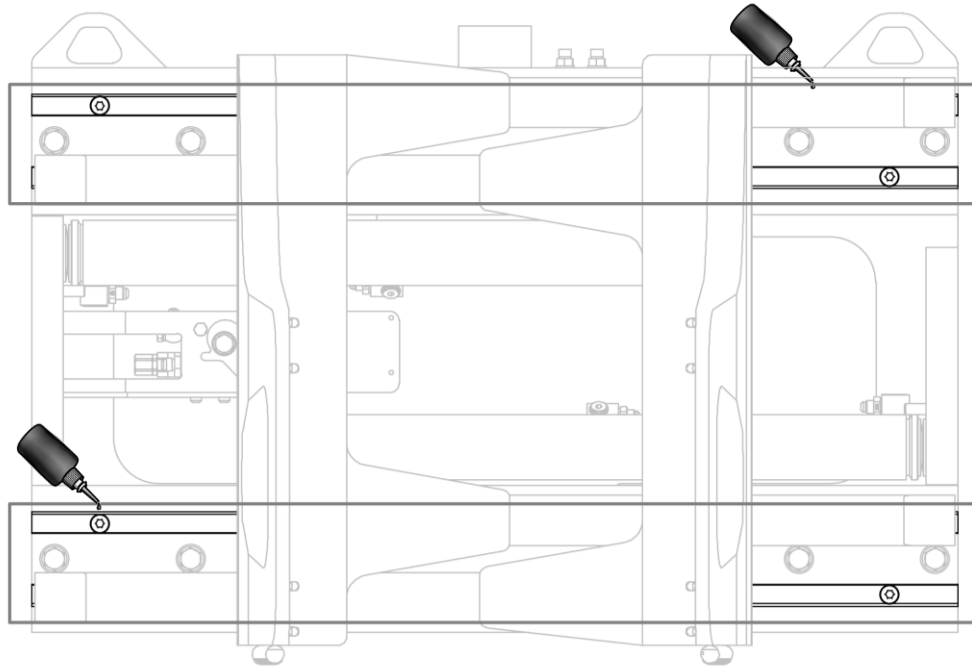

Figure 24

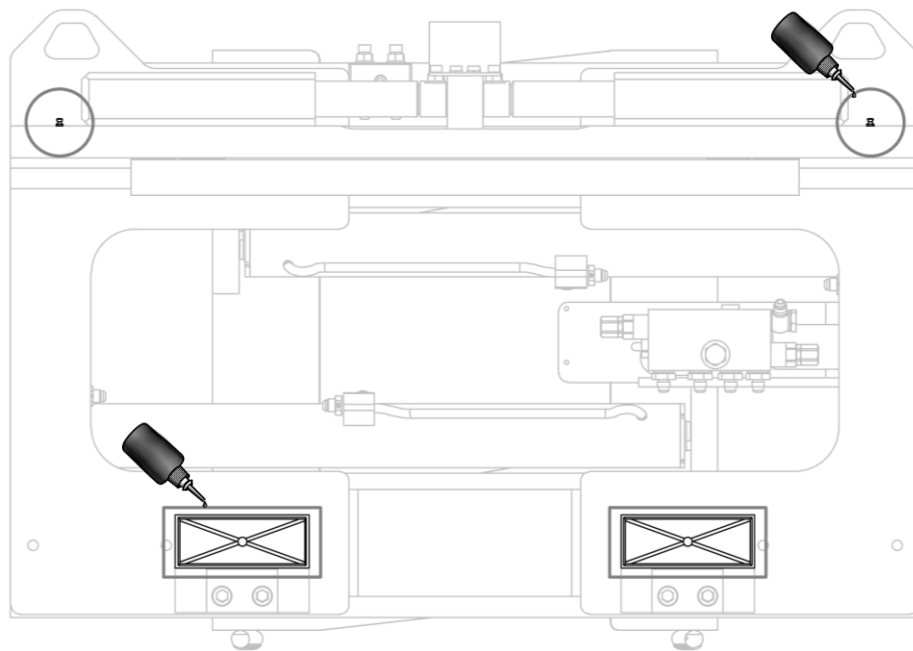

Figure 25

A.T.I.B. S.r.l.

Via Quinzanese snc, 25020 Dello (BS) - ITALY

+39 030 977 17 11

[info@atib.com](mailto:info@atib.com)

[atib.com](http://atib.com)

